



***Society of Cable
Telecommunications
Engineers***

**ENGINEERING COMMITTEE
Interface Practices Subcommittee**

AMERICAN NATIONAL STANDARD

ANSI/SCTE 48-1 2015

**Test Method for Measuring Shielding Effectiveness of
Passive and Active Devices Using a GTEM Cell**

NOTICE

The Society of Cable Telecommunications Engineers (SCTE) Standards and Recommended Practices (hereafter called documents) are intended to serve the public interest by providing specifications, test methods and procedures that promote uniformity of product, interchangeability, best practices and ultimately the long term reliability of broadband communications facilities. These documents shall not in any way preclude any member or non-member of SCTE from manufacturing or selling products not conforming to such documents, nor shall the existence of such standards preclude their voluntary use by those other than SCTE members, whether used domestically or internationally.

SCTE assumes no obligations or liability whatsoever to any party who may adopt the documents. Such adopting party assumes all risks associated with adoption of these documents, and accepts full responsibility for any damage and/or claims arising from the adoption of such Standards.

Attention is called to the possibility that implementation of this document may require the use of subject matter covered by patent rights. By publication of this document, no position is taken with respect to the existence or validity of any patent rights in connection therewith. SCTE shall not be responsible for identifying patents for which a license may be required or for conducting inquiries into the legal validity or scope of those patents that are brought to its attention.

Patent holders who believe that they hold patents which are essential to the implementation of this document have been requested to provide information about those patents and any related licensing terms and conditions. Any such declarations made before or after publication of this document are available on the SCTE web site at <http://www.scte.org>.

All Rights Reserved

© Society of Cable Telecommunications Engineers, Inc. 2015
140 Philips Road
Exton, PA 19341

TABLE OF CONTENTS

1.0	SCOPE	2
2.0	INFORMATIVE REFERENCES	2
3.0	COMPLIANCE NOTATION	2
4.0	DEFINITIONS AND ACRONYMS	3
5.0	EQUIPMENT	3
6.0	CHAMBER VERIFICATION.....	5
7.0	TEST METHOD 1	5
8.0	TEST METHOD 2	7
9.0	ERROR ANALYSIS	9
10.0	RECORDING RESULTS.....	10
	APPENDIX A: RFI/EMI SHIELDING CALCULATIONS AND METHODOLOGY.....	13
	APPENDIX B: GTEM CELL QUALIFICATION METHOD	17
	APPENDIX C: FIELD UNIFORMITY VERIFICATION METHOD	19

LIST OF FIGURES

FIGURE 1 – EQUIPMENT SETUP FOR INGRESS SHIELDING TEST (METHOD 2)	7
FIGURE A.1 – RECEIVE PATH BLOCK DIAGRAM	14
FIGURE B.1 – GTEM QUALIFICATION TEST CONFIGURATION	17
FIGURE C.1 – GTEM QUALIFICATION TEST CONFIGURATION	19

LIST OF TABLES

TABLE 1 – LEVELS OF UNCERTAINTY	9
TABLE B.1 – GTEM CELL QUALIFICATION DATA	18
TABLE C.1 – TEST CHAMBER CALIBRATION DATA	20

1.0 SCOPE

The purpose of this test is to determine the shielding effectiveness against Electromagnetic Interference (EMI) of components. This method subjects the component to an electric field of known strength.

2.0 INFORMATIVE REFERENCES

The following documents may provide valuable information to the reader but are not required when complying with this standard.

2.1 Standards from other Organizations

- Electronics Engineers' Handbook, 2nd Edition, McGraw-Hill, ISBN 0-0702-0981-2
- EMC for Product Designers, Tim Williams, 3rd Edition, Newnes, ISBN 0-7506-4930-5
- LAB 34, Edition 1, August 2002, The Expression of Uncertainty in EMC Testing, United Kingdom Accreditation Service

3.0 COMPLIANCE NOTATION

“SHALL”	This word or the adjective “REQUIRED” means that the item is an absolute requirement of this specification.
“SHALL NOT”	This phrase means that the item is an absolute prohibition of this specification.
“SHOULD”	This word or the adjective “RECOMMENDED” means that there may exist valid reasons in particular circumstances to ignore this item, but the full implications should be understood and the case carefully weighted before choosing a different course.
“SHOULD NOT”	This phrase means that there may exist valid reasons in particular circumstances when the listed behavior is acceptable or even useful, but the full implications should be understood and the case carefully weighed before implementing any behavior described with this label.
“MAY”	This word or the adjective “OPTIONAL” means that this item is truly optional. One vendor may choose to include the item because a particular marketplace requires it or because it enhances the product, for example; another vendor may omit the same item.

4.0 DEFINITIONS AND ACRONYMS

E – Electric field strength

f – Frequency in MHz

G_r – Shielding Effectiveness

K – The sum of all losses and gains between the DUT and the test equipment

G_A – The gain of any amplifier between the signal generator and GTEM cell

P_r – Power received by the DUT (ingress)

P_m – Power measured at the measurement equipment

MHz – Megahertz (1×10^6 Hz)

GTEM cell – Gigahertz Transverse Electric Field Mode Cell

kHz – Kiloherztz (1×10^3 Hz)

RF – Radio Frequency

DUT – Device Under Test

5.0 EQUIPMENT

5.1 Measurement Device

The measurement device may be a spectrum or network analyzer with the following characteristics:

- 75Ω or 50Ω Impedance Input and connector
- Capable of measuring a frequency range of 5 MHz to 1002 MHz
- Noise floor that is 10 dB or better than the DUT at 1002 MHz (minimum 10 Hz resolution bandwidth), which can be achieved with or without amplification at the input of the GTEM.

5.2 Signal Generator

Depending on the method chosen, the signal generator may be a tracking generator associated with the spectrum or network analyzer. The output power must be sufficient to create a field strength of at least 10 V/m across a test volume occupied by the DUT over the frequency range of 5 MHz to 1002 MHz. The signal generator

may be combined with a power amplifier to generate the required field strength. See section 5.6 for details of the amplifier.

5.3 GTEM Cell

The GTEM must have a test volume that is large enough to accommodate the DUT. The GTEM cell must be able to provide uniform electric field strength over the area of the DUT. The field is considered uniform if it varies by less than ± 6 dB over the area of the DUT

5.4 Adapters

75 Ω or 50 Ω min-loss pads, adapters terminations and cables as required to connect the test system and DUT.

5.5 Field Strength Monitor

The field strength-monitoring probe shall be an isotropic probe with an accuracy of ± 3 dB from 5 MHz to 1002 MHz.

5.6 Power Amplifier

The power amplifier shall have sufficient power output to generate at least 10 V/m from 5 MHz to 1002 MHz and have the following characteristics:

- Input VSWR: 2.0:1 max
- Output VSWR: 2.0:1 max
- Harmonic distortion: -15dBc max

6.0 CHAMBER VERIFICATION

- 6.1 Before any testing commences, the chamber must be verified. The verification should be performed every six month unless the chamber has been modified.
- 6.2 Follow any pre-calibration requirements using the appropriate calibration kit as recommended by the manufacturer of the test equipment, including adequate warm-up and stabilization time.
- 6.3 Follow the procedure in Appendix C to verify the field uniformity of the GTEM cell. If the cell does not meet the requirements then it is unsuitable for any of the test methods described in this document.
- 6.4 Follow the procedure in Appendix B to perform a GTEM cell qualification. If the GTEM does not meet the requirements, then test method 2 must be used. If the GTEM cell meets the requirements, either method 1 or 2 may be used.

7.0 TEST METHOD 1

- 7.1 Place the DUT centered in the test volume inside the GTEM cell. Connect one port of the DUT to the measurement device and terminate all other ports. All connections to the DUT, including power cables, must be sufficiently shielded so that their Shielding Effectiveness (Gr) is greater than the anticipated Gr of the DUT to ensure the accuracy of the test.
- 7.2 Follow any pre-calibration requirements using the appropriate calibration kit as recommended by the manufacturer of the test equipment, including adequate warm-up and stabilization time.
- 7.3 Adjust the amplifier gain into the GTEM cell to achieve a minimum of 10 V/m (20 dB V/m). Record the loss/gain of the receive path between the device under test (DUT) and the measurement device at the frequencies of interest. Record this data for future calculations. (Note: Data should be recorded in dB with losses recorded as -dB and gain recorded as +dB.) The combined loss/gain at each frequency shall be recorded as K.
- 7.4 Select a resolution bandwidth (minimum 10 Hz) to ensure that the measurement device has a noise floor that is 10 dBm or better than the DUT at 1002 MHz, which can be achieved with or without amplification at the input of the GTEM.
- 7.5 If the signal generator is a tracking generator or network analyzer, sweep the signal from 5 MHz to 1002 MHz and record the power received at the measurement device.

- 7.6 If the signal generator is only capable of providing discrete frequencies then measure and record the power on the measurement device at 5, 50, 100, 150, 200, 250, 300, 350, 400, 450, 500, 550, 600, 650, 700, 750, 800, 850, 900, 950 and 1002 MHz.
- 7.7 Record the port tested and power level as the X-axis orientation on the test report.
- 7.8 Repeat steps 7.5 to 7.7 for each input and output port on the DUT. Terminate all unused ports.
- 7.9 Rotate the DUT through 90° to the Y axis orientation Make sure that the DUT remains centered inside the test volume of the GTEM cell after rotation. Repeat steps 7.5 through 7.8.
- 7.10 Rotate the DUT through 90° to the Z axis orientation Make sure that the DUT remains centered inside the test volume of the GTEM cell after rotation. Repeat steps 7.5 through 7.8.
- 7.11 At each frequency measured, determine the worst-case measured power from each of the axes and ports. Record the frequency and the worst case power P_m . Calculate the shielding effectiveness using the following formula:

$$G_r (dB) = P_m (dBm) - K - 30 + 20 \text{Log} (f) - P_{IN} (dBm) + 20 \text{Log} (d)$$

Where:

G_r = Shielding effectiveness of DUT (dB)

P_m = Power received at measurement device (dBm)

K = Total loss or gain between DUT and measurement device (dB) (see A.3)

f = Frequency (MHz)

P_{IN} = Power into GTEM cell (dBm) = $P_{OUT} + G_A$

G_A = The gain of any amplifier between the signal generator and GTEM cell (dB)

P_{OUT} = The power level out of the signal generator (dBm)

d = Septum height (m)

See Appendix A for the derivation of this equation.

8.0 TEST METHOD 2

- 8.1 Follow any pre-calibration requirements using the appropriate calibration kit as recommended by the manufacturers of the test equipment, including adequate warm-up and stabilization time.
- 8.2 Connect the equipment as shown in Figure 1. This diagram assumes the use of a tracking generator, external RF amp, and a calibrated field strength-monitoring probe.
- 8.3 Set the measurement device and signal generator to 5 MHz. Connect the generator output through the power amplifier (if required) to the GTEM cell. Place the three-axis field probe in the center of the test volume inside of the GTEM cell. Adjust the signal generator output power for an E-field strength of $10 \text{ V/m} + 1 \text{ V/m}$ ($+20 \text{ dB V/m}$). Record field strength, and signal generator output power level (or level on power meter) for future testing.

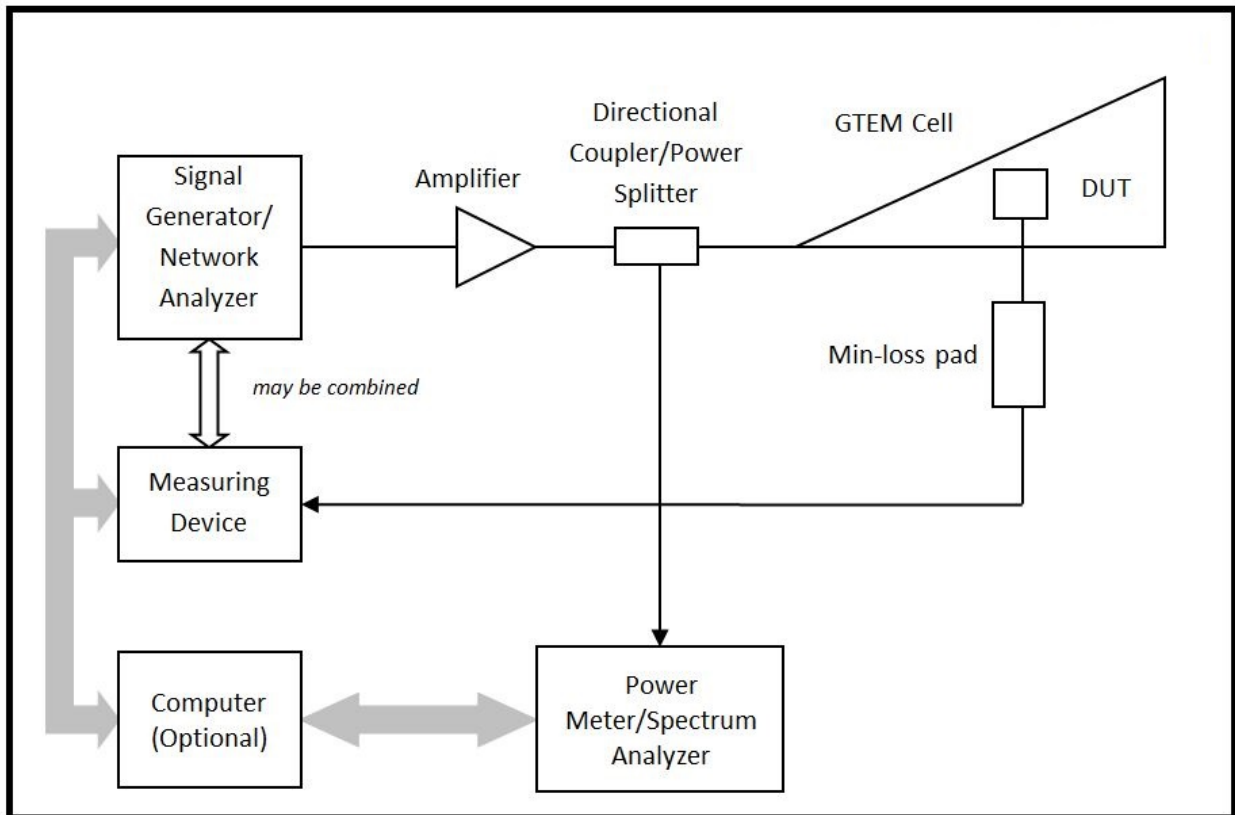

Figure 1 – Equipment Setup for Ingress Shielding Test (Method 2)

- 8.4 Repeat step 8.3 for all of the frequencies of interest including but not limited to: 50, 100, 150, 200, 250, 300, 350, 400, 450, 500, 550, 600, 650, 700, 750, 800, 850, 900, 950 and 1002 MHz.
- 8.5 Measure the loss/gain of the receive path between the device under test (DUT) and the measurement device at the frequencies of interest. Record this data for future

calculations. (Note: Data should be recorded in dB with losses recorded as –dB and gain recorded as +dB.) The combined loss/gain at each frequency shall be recorded as K (see Appendix A for an example).

- 8.6 Replace the field probe with the DUT centered in the test volume inside of the GTEM cell. Connect one port of the DUT to the measurement device (see figure 1) and terminate all of the other ports. Adjust the signal generator for the selected test frequency and the corresponding output power measured in step 8.3. All connections to the DUT, including power cables, must be sufficiently shielded to ensure the accuracy of the test. All cables and connections required inside the GTEM should be placed and routed in a manner that will minimize any field perturbations.
- 8.7 Select a resolution bandwidth (minimum 10 Hz) to ensure that the measurement device has a noise floor that is 10 dBm or better than the DUT at 1002 MHz, which can be achieved with or without amplification at the input of the GTEM. Measure the ingress level on the spectrum analyzer and record this level as the X-axis orientation in the test report.
- 8.8 Repeat steps 8.6 through 8.7 at the frequencies specified in 8.3 and 8.4.
- 8.9 Repeat steps 8.6 through 8.8 for each entry and exit on the DUT.
- 8.10 Rotate the DUT 90° to the Y-axis orientation. Make sure that the DUT remains centered inside the test volume of the GTEM cell after rotation. Repeat step 8.6 through 8.9.
- 8.11 Rotate the DUT 90° to the Z-axis orientation. Make sure that the DUT remains centered inside the test volume of the GTEM cell after rotation. Repeat step 8.6 through 8.9.
- 8.12 Calculate the shielding effectiveness of the DUT from the following formula. Use the worst case ingress/egress signal power measured in the X, Y, or Z-axis as Pm. Replace K with the Loss/Gain data measured in step 8.5 at the test frequency. Use E(dBV /m) measured in step 8.4 at the test frequency. Calculate the RF shielding from the following formula and record in the test report.

$$Gr = Pm(\text{dBm}) - K(\text{dB}) - 42.8\text{dB} + 20\text{Log}(f) - E(\text{dBV} / \text{m})$$

See Appendix A for the derivation of this equation, (*f* is in MHz)

9.0 ERROR ANALYSIS

The accuracy of measurements taken using this test method is limited by several factors, including:

- The variation between calculated and measured field strength (Method 1) or accuracy of field probe (Method 2)
- The variations in the field at the DUT as it is rotated in the test volume
- Resonance between the GTEM cell and the DUT
- The accuracy of the measurement device over a large dynamic range
- The accuracy of the receive path gain / loss measurements

The estimated accuracy for this test method can be calculated by determining the uncertainty values for each relevant component. The following table can be used as a template for determining the overall uncertainty.

Table 1 – Levels of Uncertainty

Factor	Accuracy
Variation between calculated and measured field strength / Field Probe Accuracy	± 2.0 dB / ± 1.0 dB
Field Variation over test volume ¹	± 5.0 dB
Receive path / gain loss accuracy	± 0.5 dB
Spectrum Analyzer measurement accuracy	± 1.7 dB
Accuracy of amplifier between signal generator and GTEM cell	± 2.0 dB
Assuming each component has a rectangular distribution then	
Best Error Estimate (Method 1)	± 6.94 dB

¹ Typical manufacturer specification of ± 4 dB plus ± 1 dB septum height variation in respect to depth of the DUT

For a rectangular distribution, the standard uncertainty for each component $u_i(x)$ can be calculated from the formula:

$u_i(x) = \frac{a_i}{\sqrt{3}}$, where a_i is the accuracy of the measurement (eg $a_i = 2.0$ if accuracy is ± 2.0 dB)

For a 95% confidence level, the best estimate error can be calculated by taking the square root of the sum of the squares of $u_i(x)$ and multiplying the result by 2, i.e.

$$\text{Best Error Estimate} = 2 \times \sqrt{\sum_{i=1}^n u_i^2(x)}$$

10.0 RECORDING RESULTS

10.1 While the exact form of data recording will be application dependent, results as a minimum should include:

- Frequencies Tested
- Type of device and identity of the specific sample tested
- Identity of the person performing the test
- Date of the test
- Values of ingress measured at each frequency
- Calculation of the measurement accuracy
- List of equipment used
- Calibration due date of the test equipment

10.2 Typical test result forms for method 1 and method 2 are shown on the next two pages

TEST RESULTS: SHIELDING EFFECTIVENESS (Method 1)

IDENTITY OF DEVICE TESTED

Type of device: _____
 Manufacturer: _____ Model Number: _____
 Serial or Lot number _____ Port identification: _____

Ingress Data (Measured Power at Measurement Device)

Frequency (MHz)	P_{in} (dB m)	K (dB)	$P_m(X)$ (dB m)	$P_m(Y)$ (dB m)	$P_m(Z)$ (dB m)	Shielding Effectiveness G_r (dB)
5						
50						
100						
150						
200						
250						
300						
350						
400						
450						
500						
550						
600						
650						
700						
750						
800						
850						
900						
950						
1002						

$$G_r (dB) = P_m (dBm) - K - 30 + 20 \text{Log} (f) - P_{IN} (dBm) + 20 \text{Log} (d)$$

Accuracy Estimate

Factor	Accuracy
Variation between calculated and measured field	± dB
Field Variation over test volume	± dB
Receive path / gain loss accuracy	± dB
Spectrum Analyzer measurement accuracy	± dB
Accuracy of amplifier between signal generator and GTEM cell	± dB
Worst Case Error	± dB

Tested By

Technician:		Date	
-------------	--	------	--

TEST RESULTS: SHIELDING EFFECTIVENESS (Method 2)

IDENTITY OF UNIT TESTED

Type of device: _____
 Manufacturer: _____ Model Number: _____
 Serial or Lot number _____ Port identification: _____

Ingress Data (Measured Power at Measurement Device)

Frequency (MHz)	E (dBV / m)	K	$P_m(X)$	$P_m(Y)$	$P_m(Z)$	Shielding Effectiveness G_r (dB)
5						
50						
100						
150						
200						
250						
300						
350						
400						
450						
500						
550						
600						
650						
700						
750						
800						
850						
900						
950						
1002						

$$G_r = P_m(\text{dBm}) - K(\text{dB}) - 42.8\text{dB} + 20\text{Log}(f) - E(\text{dBV} / \text{m})$$

Accuracy Estimate

Factor	Accuracy
Field Probe Accuracy	± dB
Field Variation over test volume	± dB
Receive path / gain loss accuracy	± dB
Spectrum Analyzer measurement accuracy	± dB
Accuracy of amplifier between signal generator and GTEM cell	± dB
Worst Case Error	± dB

Tested By

Technician:		Date	
-------------	--	------	--

APPENDIX A: RFI/EMI SHIELDING CALCULATIONS AND METHODOLOGY

A.1 E-Field Strength in the GTEM cell calculations

The field inside the GTEM cell is calculated from the power applied to the cell and the impedance of the cell. The voltage in the GTEM cell is calculated from the power equation:

$$P_{IN} = \frac{V^2}{Z} \quad [1]$$

$$\therefore V = \sqrt{P_{IN} \times Z} \quad \text{or} \quad V = P_{IN}^{1/2} \times Z^{1/2} \quad [2]$$

Taking 20Log of both sides gives us:

$$20\text{Log}V = 10\text{Log}(P_{IN}) + 10\text{Log}(Z) \quad [3]$$

Given that $Z = 50\Omega$, then

$$V(\text{dBV}) = P_{IN}(\text{dBW}) + 17 \quad [4]$$

The electric field strength in the center of the GTEM cell is calculated from the voltage on the cell septum (V) and the distance between the septum and the bottom of the GTEM cell in meters (d), ie:

$$E = \frac{V}{d} \quad [5]$$

again, taking 20log of both sides gives

$$20\text{Log}(E) = 20\text{Log}(V) - 20\text{Log}(d) \quad [6]$$

or

$$E(\text{dBV} / m) = V(\text{dBV}) - 20\text{Log}(d) \quad [7]$$

Substituting equation [4] in [7], gives

$$E(\text{dBV} / m) = P_{IN}(\text{dBW}) + 17 - 20\text{Log}(d) \quad [8]$$

or

$$E(\text{dBV} / m) = P_{IN}(\text{dBm}) - 13 - 20\text{Log}(d) \quad [9]$$

A.2 Example of an E-field Strength Calculation

Calculate the E-Field strength in the GTEM cell if a power amplifier with a +30dBm output level is used to drive the cell ($P_{IN} = +30$). The input impedance of the cell is 50Ω and the septum height is 0.63m (25 inches) ($20\text{Log}(0.63) = -4\text{ dB}$)

$$E = +30 - 13 - (-4)$$

$$E = 21\text{ dBV} / m$$

A.3 Ingress Power Calculation

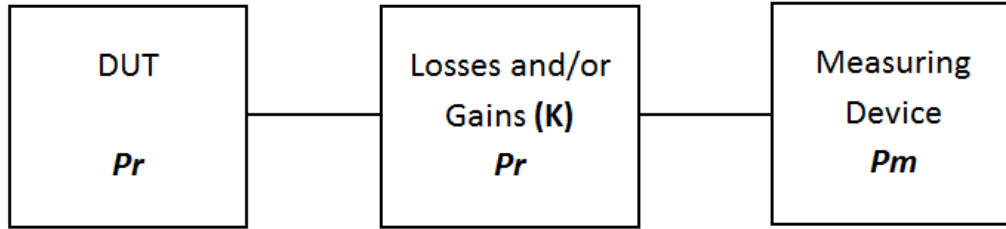

Figure A.1 – Receive Path Block Diagram

K is equal to the losses or gain between DUT and measurement device. Record a loss as a negative number and a gain as a positive number.

Example:

Suppose that between the DUT and Measurement device there is a cable with a loss of 2dB and an amplifier with a 30 dB gain, and a 75Ω to 50Ω adapter with a loss of 5.7 dB then:

$$K = 30 - 2 - 5.7$$

$$K = 22.3 \text{ dB}$$

If the amplifier were removed then K would equal -7.7 dB

$$P_r (\text{dBm}) = P_m (\text{dBm}) - K (\text{dB}) \quad [10]$$

The relationship between the electric field inside the GTEM cell and the power received P_r can be derived from the following equations:

$$P_r = P_d A_e \quad [11]$$

P_d = Power Density (W/m^2)

P_r = Received Power at output of DUT

A_e = Antenna Effective Area (m^2)

$$P_d = \frac{P_T G_T}{4\pi d^2} \quad \text{or} \quad P_d = \frac{E^2}{120\pi} \quad [12]$$

P_T = Power Transmitted into Transmit Antenna (Watts)

G_T = Gain of Transmitting antenna (dBi)

d = distance between transmit antenna and DUT (m)

E = Field Strength at DUT (V/m)

$A_e = \frac{\lambda^2}{4\pi}$ for an isotropic antenna and thus $A_e = \frac{\lambda^2 G_r}{4\pi}$ for any other antenna [13]

G_r = Gain of Receiving antenna

λ = Wavelength (m)

$$\therefore P_r = \frac{P_t G_t G_r \lambda^2}{(4\pi d)^2} = \frac{E^2 \lambda^2 G_r}{120\pi \times 4\pi} = \frac{E^2 \lambda^2 G_r}{480\pi^2} \quad [14]$$

Equation [14] is known as the Friis Equation

It can be assumed that the gain of the receiving antenna is equal to the shielding effectiveness and therefore G_r is equal to the shielding effectiveness of the DUT.

If the electric field at the DUT is known, then:

$$G_r = \frac{480\pi^2 P_r}{E^2 \lambda^2} = \text{Shielding Effectiveness} \quad [15]$$

given $c = f \times \lambda$, then if f is in MHz, equation 15 becomes

$$G_r = \frac{480\pi^2 P_r f^2}{E^2 \times 300^2} = \text{Shielding Effectiveness} \quad [16]$$

Multiplying both sides by 10Log_{10} gives:

$$10\text{Log}(G_r) = 10\text{Log}\left(\frac{480\pi^2 P_r f^2}{E^2 300^2}\right) \quad [17]$$

the terms in brackets may be expanded giving:

$$10\text{Log}(G_r) = 10\text{Log}(480\pi^2) + 10\text{Log}(P_r) + 20\text{Log}(f) - 20\text{Log}(E) - 10\text{Log}(300^2) \quad [18]$$

Given that $10\text{Log}(P_r)$ is the dB equivalent, then the equation may be re-written as:

$$G_r(\text{dB}) = 36.75 + P_r(\text{dBW}) + 20\text{Log}(f) - E(\text{dBV/m}) - 49.5 \quad [19]$$

re-arranging gives:

$$G_r(\text{dB}) = P_r(\text{dBW}) - 12.8 + 20\text{Log}(f) - E(\text{dBV/m}) \quad [20]$$

Where E is in dBV/m and f is in MHz

Finally, substituting equations [9] and [10] into [20] gives:

$$G_r(\text{dB}) = P_m(\text{dBW}) - K - 12.8 + 20\text{Log}(f) - P_{IN}(\text{dBm}) + 13 + 20\text{Log}(d) \quad [21]$$

which is approximately equal to:

$$G_r(\text{dB}) = P_m(\text{dBm}) - K - 30 + 20\text{Log}(f) - P_{IN}(\text{dBm}) + 20\text{Log}(d) \quad [22]$$

G_r = Shielding effectiveness of DUT (dB)

P_m = Power received at measurement device (dBm)

f = Frequency (MHz)

P_{IN} = Power into GTEM cell (dBm)

d = Septum height (m)

K = Total loss or gain between DUT and measurement device (dB)

APPENDIX B: GTEM CELL QUALIFICATION METHOD

B.1 Connect the equipment as shown in Figure B.1

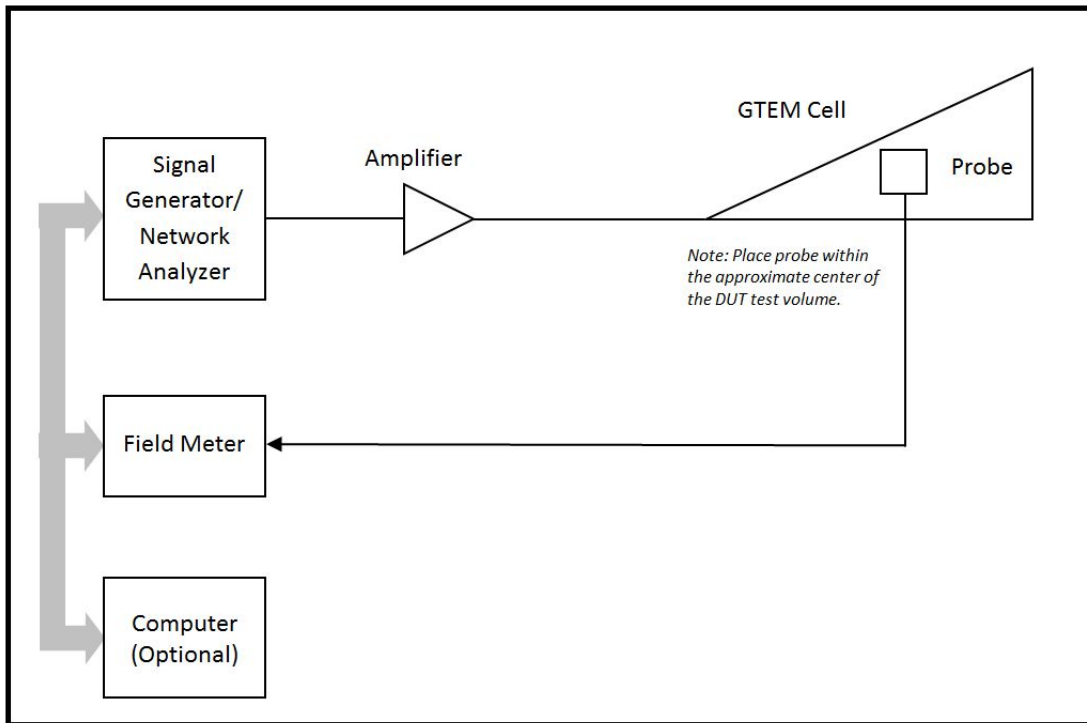

Figure B.1 – GTEM Qualification Test Configuration

- B.2 Measure the insertion loss/gain between the signal generator and the GTEM cell and record this value as **K**. A gain will be recorded as a positive value and a loss shall be recorded as a negative value. See A.3 for an example.
- B.3 Set the frequency of the signal generator to 5 MHz and record the field on the isotropic field probe (in dB(V/m)) and the power into the GTEM cell (P_{GTEMIN}). ($P_{GTEMIN} = P_{OUT} - K$). Table B.1 may be used to record the data for future use.
- B.4 Repeat B.3 for the following frequencies: 50, 100, 150, 200, 250, 300, 350, 400, 450, 500, 550, 600, 650, 700, 750, 800, 850, 900, 950 and 1002 MHz
- B.5 Use the following formula (equation [9]) to calculate the predicted Electric field strength inside the GTEM cell:

$$E(dBV / m) = P_{GTEMIN}(dBm) - 13 - 20\text{Log}(d)$$

where d is the septum height of the GTEM cell in meters.

- B.6 Compare calculated Electric field and actual electric field measurements from the isotropic field probe

B.7 If the calculated field strength is equal to the recorded field strength ± 2 dB then the chamber is qualified for further use without the use of an isotropic field probe.

Table B.1 – GTEM Cell Qualification Data

Frequency (MHz)	Power Out of Sig Gen (P_{OUT})	Loss/Gain (K)	Power into GTEM ($P_{OUT} - K$)	Recorded E-Field(dB) (A)	Calculated E-Field(dB) (B)	Delta (A - B)
5						
50						
100						
150						
200						
250						
300						
350						
400						
450						
500						
550						
600						
650						
700						
750						
800						
850						
900						
950						
1002						

APPENDIX C: FIELD UNIFORMITY VERIFICATION METHOD

C.7 Connect the equipment as shown in figure C.1. If the amplifier is calibrated and stable, the directional coupler and power meter may be omitted.

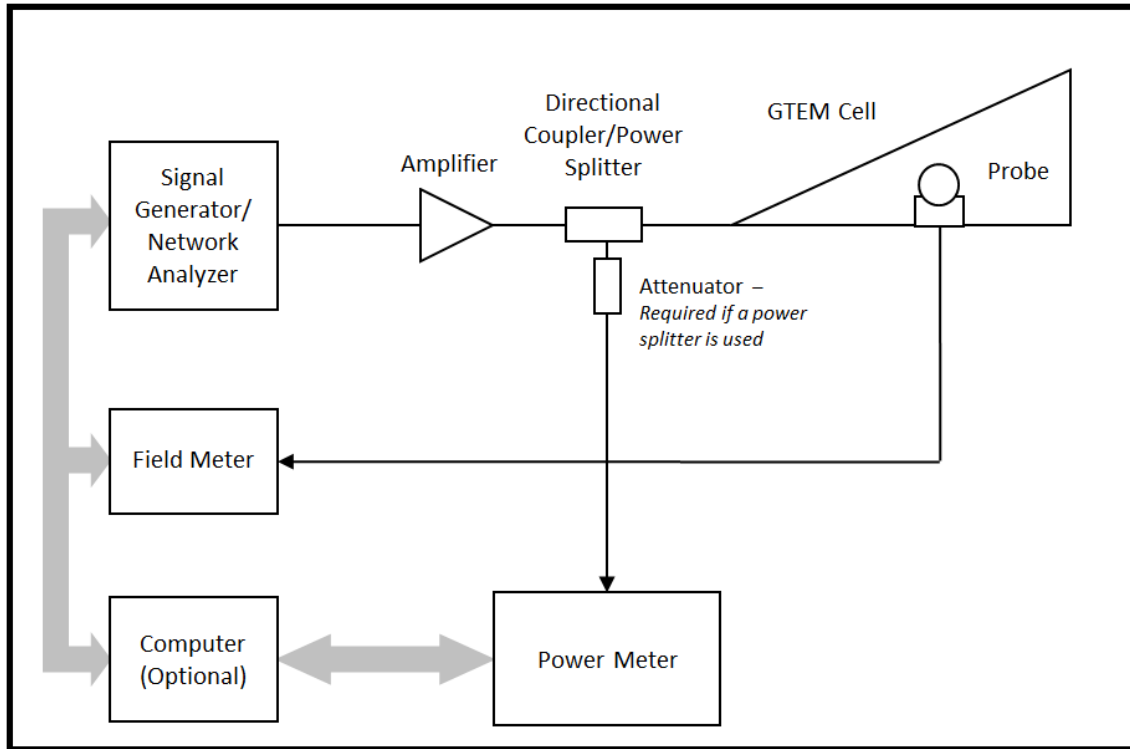

Figure C.1 – GTEM Qualification Test Configuration

- C.2 Determine the maximum dimension of likely DUT's and from these dimensions determine the position of the eight corners inside the GTEM cell.
- C.3 Place the field probe in the center of the test volume inside the GTEM cell.
- C.4 Set the frequency on the analyzer to 5 MHz, and adjust the amplitude until the level on the field probe reads $10 \text{ V/m} \pm 1 \text{ V/m}$ (+20 dBV/m).
- C.5 Record the field strength and either the level on the power meter or the signal generator output level (if directional coupler not used). Table C.1 may be used to record the field strength data.
- C.6 Move the field probe and measure the E-field strength at each of the eight corners of the required test volume. If the maximum height of the DUT is less than that of the field probe, it is acceptable to measure only the four corners at the level of the DUT.

- C.7 If the field varies by more than ± 5 dB, then reduce the volume if possible. If this criterion cannot be met due to the size of the DUT, adjust the test level such that the field is within ± 5 dB. Note the test level within the test report.
- C.8 Repeat steps C.4 to C.7 for each of the following frequencies: 50, 100, 200, 400, 700 and 1002 MHz

Table C.1 – Test Chamber Calibration Data

Probe Location	Field Strength	Frequency (MHz)						
		5	50	100	200	400	700	1002
Center	V/m							
	dBV/m							
Corner 1	V/m							
	dBV/m							
Corner 2	V/m							
	dBV/m							
Corner 3	V/m							
	dBV/m							
Corner 4	V/m							
	dBV/m							
Corner 5	V/m							
	dBV/m							
Corner 6	V/m							
	dBV/m							
Corner 7	V/m							
	dBV/m							
Corner 8	V/m							
	dBV/m							
MAX	dBV/m							
MIN	dBV/m							
DELTA (MAX-MIN)	dB							