



***Society of Cable
Telecommunications
Engineers***

**ENGINEERING COMMITTEE
Interface Practices Subcommittee**

AMERICAN NATIONAL STANDARD

ANSI/SCTE 86 2010

**SCTE Recommended Optical Fiber Cable Types for Outside
Plant Trunk and Distribution Applications**

NOTICE

The Society of Cable Telecommunications Engineers (SCTE) Standards are intended to serve the public interest by providing specifications, test methods and procedures that promote uniformity of product, interchangeability and ultimately the long term reliability of broadband communications facilities. These documents shall not in any way preclude any member or non-member of SCTE from manufacturing or selling products not conforming to such documents, nor shall the existence of such standards preclude their voluntary use by those other than SCTE members, whether used domestically or internationally.

SCTE assumes no obligations or liability whatsoever to any party who may adopt the Standards. Such adopting party assumes all risks associated with adoption of these Standards, and accepts full responsibility for any damage and/or claims arising from the adoption of such Standards.

Attention is called to the possibility that implementation of this standard may require the use of subject matter covered by patent rights. By publication of this standard, no position is taken with respect to the existence or validity of any patent rights in connection therewith. SCTE shall not be responsible for identifying patents for which a license may be required or for conducting inquiries into the legal validity or scope of those patents that are brought to its attention.

Patent holders who believe that they hold patents which are essential to the implementation of this standard have been requested to provide information about those patents and any related licensing terms and conditions. Any such declarations made before or after publication of this document are available on the SCTE web site at <http://www.scte.org>.

All Rights Reserved

© 2005, 2010 Society of Cable Telecommunications Engineers, Inc. 2010
140 Philips Road
Exton, PA 19341

TABLE OF CONTENTS

1.0	INTRODUCTION	1
2.0	NORMATIVE REFERENCES	1
3.0	TYPICAL INSTALLATION APPLICATIONS	1
4.0	TYPICAL OPTICAL FIBER DESIGNS.....	3
5.0	TYPICAL OSP CABLE DESIGNS	6
6.0	PERFORMANCE REQUIREMENTS	12
7.0	SELECTION GUIDE & APPLICATION CONSIDERATIONS	12

LIST OF FIGURES

FIGURE 1 – CHROMATIC DISPERSION IN OPTICAL FIBER	5
FIGURE 2 – SPECTRAL ATTENUATION CURVE FOR OPTICAL FIBER	6
FIGURE 3 – STRANDED LOOSE TUBE CABLE (BUNDLED FIBERS)	7
FIGURE 4 – STRANDED LOOSE TUBE CABLE (RIBBONIZED FIBERS)	8
FIGURE 5 – CENTRAL TUBE CABLE (BUNDLED FIBERS)	9
FIGURE 6 – FIGURE-8 CABLE DESIGN	10
FIGURE 7 – ALL DIELECTIC SELF SUPPORTING (ADSS) CABLE DESIGN	11

1.0 INTRODUCTION

Optical fiber cable is a key component of any service provider's passive optical network for telecommunications applications. Optical fiber cables comprise a significant portion of Hybrid Fiber Coax (HFC) networks in service today. Ensuring the long term reliability of these assets is a key performance component to the service providers and network operators.

Optical cables are designed to protect the optical fibers from a variety of harmful effects that could degrade the ultimate service life of the network. The effects of mechanical stresses, such as those experienced during installation, must be considered. Environmental effects that typically manifest themselves post-installation, such as temperature changes and chemical exposure, should also be evaluated. In order to properly evaluate and compare different cable designs a test regime of standard performance requirements should be considered by network operators. Well-designed and properly installed cables will protect the optical fibers and ensure proper operation for 20 years or more.

The purpose of this document is to provide guidance in selection of a suitable outside plant (OSP) optical cable with respect to different application environments.

2.0 NORMATIVE REFERENCES

The following documents contain provisions, which, through reference in this text, constitute provisions of this standard. At the time of publication, the editions indicated were valid. All standards are subject to revision, and parties to agreement based on this standard are encouraged to investigate the possibility of applying the most recent editions of the documents listed below.

ANSI/ICEA S-87-640, *Standard for Optical Fiber Outside Plant Communications Cable.(Current version)*

3.0 TYPICAL INSTALLATION APPLICATIONS

The main trunk and distribution application categories can be defined as follows:

- Aerial installation
- Direct Buried Installation
- Duct Installation
- Special Applications

These installation methods are used in either new builds (“Greenfield” applications), rehabilitation of existing networks (“Brownfield” applications), or overbuilding existing networks. A basic overview of each installation method can be described as follows:

3.1 Aerial

An aerial cable installation typically entails placement of the optical cable on poles or towers, which allows routing of the optical transmission path above ground. The most common method of stringing the optical cable from pole to pole is lashing the cable to a metallic messenger wire. The diameter and strength of this messenger wire is dependent upon the span distance between the poles and the expected seasonal environmental conditions. The cable is lashed to the messenger wire using a machine that wraps a small, continuous wire around both the messenger and optical cable in a spiral manner. The lashing wire is mechanically secured to the messenger wire with attachment hardware to prevent it from loosening.

A subset of aerial installations is “self supported” cable applications. These aerial installations are accomplished with optical cables engineered to support themselves without an independent messenger wire. Typically, the metallic or dielectric supporting elements of a self-supported cable are incorporated into the cable design. The benefit of this cable design is that the installation process requires only one step rather than the two-step process associated with lashed aerial installations.

3.2 Direct Buried

A direct-burial installation typically involves heavy machinery and places the optical cable underground in direct contact with earth and rocks that make up the surrounding soil. The optical cable is inserted into the ground by either creating a ditch or utilizing a vibratory plow. A ditch installation involves a two step process (to create and then backfill) and is frequently used to collocate different service cables. The process incorporating a vibratory plow creates an opening in the ground, inserts the cable, and then closes the opening to secure the cable below ground. This method is typically dedicated to a single service provider.

3.3 Duct

A duct cable installation typically involves placement of one or more optical cables inside a preinstalled duct that runs between access points. An access point can be as large as a manhole vault or as small as a simple handhole. This type of installation usually requires a prime mover device (can be manual, a mechanized winch, or cable jetting equipment), a tension measuring device, and compatible lubricant to allow the cable to slide through the conduit with reduced frictional drag.

3.4 Special Applications

Special applications include those methods of placing optical fiber cables that are not normally used in typical aerial and underground construction. These methods include:

- **Air-assisted cable placement**
- **Submarine cable placement**
- **Cable placement on bridges**
- **Cables suitable for indoor/outdoor applications**

4.0 TYPICAL OPTICAL FIBER DESIGNS

From a material standpoint, optical fiber is composed of ultra-pure silica, which is almost 200,000 times more pure than window glass. Optical fiber is extremely strong and very flexible. An optical fiber has the bending strength to provide reliable, long-term operation when placed in bends as small as one inch in radius. The tensile strength (resistance to longitudinal stress) is comparable to that of the strongest materials – including steel. Even though the dimensions of an optical fiber closely approximate that of a human hair, its theoretical strength is extremely high and its durability has been proven in a variety of adverse environments.

Since initially developed in the 1970's, a number of different fused silica glass optical fiber designs have been utilized in telecommunication networks. There are two general classifications of optical fiber types: multimode and single-mode. Multimode optical fiber was the first type of optical fiber to be developed and commercialized and has a core that is much larger than that of single-mode optical fiber. As its name suggests, multimode fiber can simultaneously transmit the optical signal over multiple stable pathways, also termed "modes," inside the core. Single-mode optical fiber, with its much smaller core area, supports optical transmission on only one stable mode. Relative to single-mode fiber, Multimode fiber is distance limited and most frequently used in applications less than two kilometers in overall length.

Cable telecommunications system applications are best supported by a single-mode optical fiber solution. Advancements in design/manufacturing technology have enabled the availability of a variety of different single-mode optical fibers. The differentiation of these is usually related to the refinement of one or more performance attributes to address a specific application requirement. For example, there are specific single-mode fiber designs best suited for applications requiring transmission distances of under 50 kilometers and other single-mode fiber designs best suited for applications requiring transmission distances over hundreds of kilometers. Technical evaluation is necessary to identify which

fiber design is best suited for the specific application under consideration. A basic understanding of the optical transmission principles and limitations is necessary to assist in making an informed selection. Typically, initial performance discussions focus on two basic operating limitations that directly impact transmission of the optical signal - chromatic dispersion and attenuation.

Chromatic dispersion refers to the effect that causes the optical signal to “spread out” as it travels along the optical fiber. Since the pulses are transmitted in sequence, this pulse spreading will cause the leading edge on one pulse to approach the trailing edge of the pulse ahead of it. This effect becomes problematic when the leading edge of one pulse overtakes the trailing edge of the pulse ahead of it. Attenuation refers to the reduction of signal strength as the light pulse moves down the optical fiber away from the transmitter. This effect creates problems when the signal strength is reduced to a point where it can no longer be interpreted by the receiver.

4.1 Dispersion-Unshifted (“Standard”) Single-Mode Optical Fiber

The most common single-mode optical fiber is technically termed as “dispersion-unshifted.” This design has been the telecommunications workhorse for many years and is also known as “standard single-mode fiber.” This optical fiber is optimized for use in the 1310 nm operating wavelength range and is also capable of supporting transmission in the 1550 nm operating wavelength range. System operation at 1310 nm was the first single-mode transmission range significantly utilized for single-mode telecommunication purposes. System operation at 1550 nm evolved because this operating range provided lower signal attenuation than operation at 1310 nm and therefore longer reach could be achieved. The downside of operating a 1550 nm system on standard single-mode optical fiber was that the chromatic dispersion was more than five times higher than experienced at 1310 nm. The wavelength dependence of chromatic dispersion is illustrated in Figure 1 that follows.

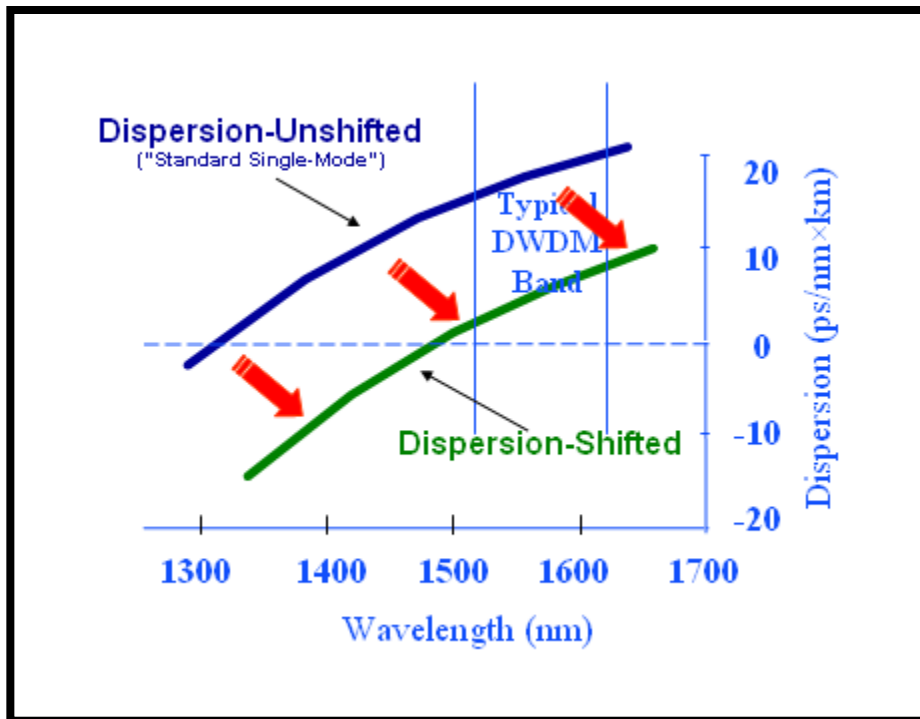

Figure 1 – Chromatic Dispersion in Optical Fiber

4.2 Dispersion-Shifted Single-Mode Optical Fiber

In order to address the limitations imposed by higher chromatic dispersion observed in standard single-mode optical fibers in the 1550 nm region, an optical fiber design was developed to shift the low chromatic dispersion performance to coincide with the lower attenuation region in the 1550 nm region. The general effect of this “shift” is illustrated in Figure 1. The first versions of this modified single-mode optical fiber were termed “dispersion-shifted” and required a more complex waveguide design. There were two significant consequences of this design. First, the new waveguide design was more challenging to manufacture and second, concurrent acceptable performance in the 1310 nm region could not be guaranteed. The advent of wave division multiplexing (WDM) obsoleted this fiber design (due to the impact of multi-wavelength non-linear effects) and resulted in the follow-on development of a next generation product – technically termed “non-zero dispersion-shifted” single-mode optical fiber. Like its dispersion-shifted predecessor, the non-zero dispersion-shifted design was a complex waveguide design that did not guarantee acceptable 1310 nm performance. However, it does provide a viable technical solution for applications requiring WDM in the 1550 nm operating window.

4.3 Low Water Peak Attenuation Single-Mode Optical Fiber

The water peak region of the spectral attenuation curve, in the vicinity of 1383 nm, has historically demonstrated elevated attenuation (see Figure 2) due to hydroxyl ions

entrapped in the glass structure during the manufacturing process. Advances in technology have now enabled significantly improved attenuation performance in this region of the spectral attenuation curve. This level of performance enables a larger percentage of the optical spectrum to be available for telecommunications applications such as coarse wave division multiplexing (CWDM). The low water peak attenuation performance can be applied to both standard and dispersion-shifted optical fiber designs; however, in current practice it is mostly considered only with standard single-mode designs. The chromatic dispersion properties of the low water peak optical fiber would be equivalent to the standard single-mode optical fiber discussed above and this performance is specified in published standards documents.

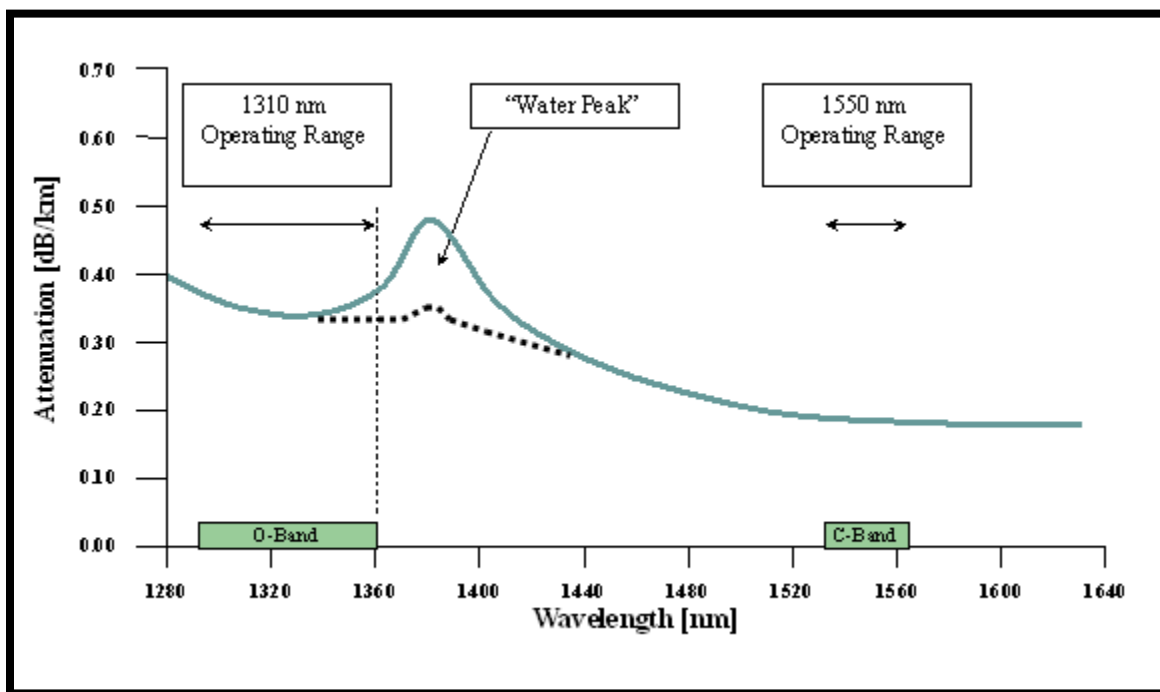

Figure 2 – Spectral Attenuation Curve for Optical Fiber

5.0 TYPICAL OSP CABLE DESIGNS

Since the first optical cable deployments in the 1970's a number of different optical cable designs have been developed. The basic aim of each of these designs is similar – to protect the optical fibers from damage during installation and over their useful service lifetime. Different application and “handleability” considerations will determine specific preferences of one cable type over another. The cable designs presented in this document are the most commonly used in the telecommunication industry today.

5.1 Stranded Loose Tube

Stranded Loose Tube cables have the optical fibers placed in bundles or ribbons in each individual buffer tube. A cable core for this design is comprised of multiple color-coded unit tubes (loose tubes) reverse lay stranded around a central strength member. The central member is responsible for providing support for the tubes as well as some traction resistance. The reverse lay stranding configuration enables easy mid-span access. This cable design may also have aramid or fiberglass yarns stranded below its external jacket in order to increase its tensile strength. The interior of the cable is protected from moisture intrusion by a water blocking material. The cable core may be afforded additional protection with corrugated metallic armor. The fiber bundle design (shown in Figure 3) is the most commonly used optical distribution type in the cable telecommunications systems industry today.

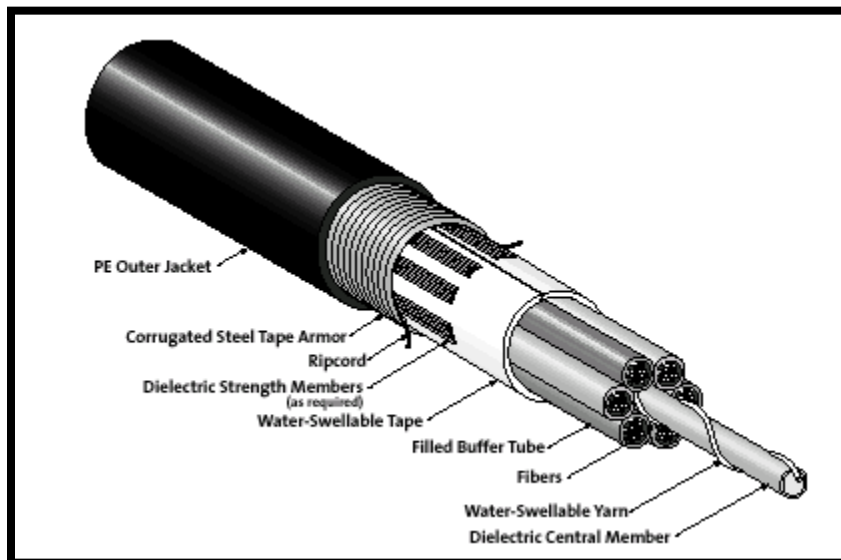

Figure 3 – Stranded Loose Tube Cable (Bundled Fibers)

The stranded loose tube cable design incorporating ribbons (shown in Figure 4) is a more recent design and is typically used for applications requiring fiber counts greater than 300. The fiber ribbons are typically made up of 12 color coded fibers configured in a planar array and held together in an acrylate matrix material.

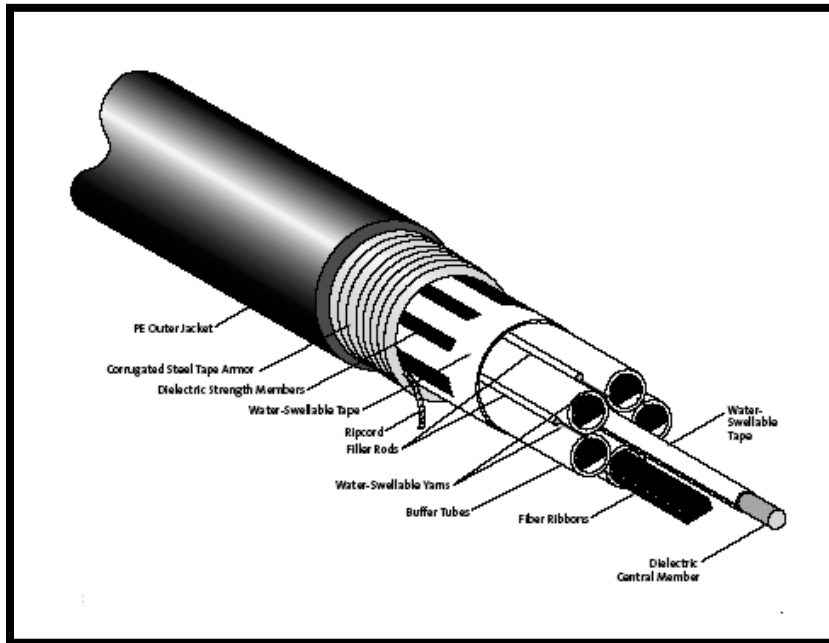

Figure 4 – Stranded Loose Tube Cable (Ribbonized Fibers)

5.2 Central Tube

Central Tube cables are an “alternative” loose tube cable design. Similar to the stranded design, the fibers (either grouped in bundles or ribbons) are placed in an oversized plastic buffer tube. This primary differentiating feature of this cable design is that there is one larger single tube in the center of the cable rather than multiple smaller diameter tubes stranded around a central member. Strength members are placed around the main central tube, and are commonly imbedded in the outer jacket, in order to provide traction and compression resistance. The maximum fiber count of central tube bundled designs is limited compared to its stranded multi-tube counterpart. The maximum fiber count of central tube ribbon designs may exceed those available in stranded multi-tube counterparts. An example of this design is depicted in Figure 5.

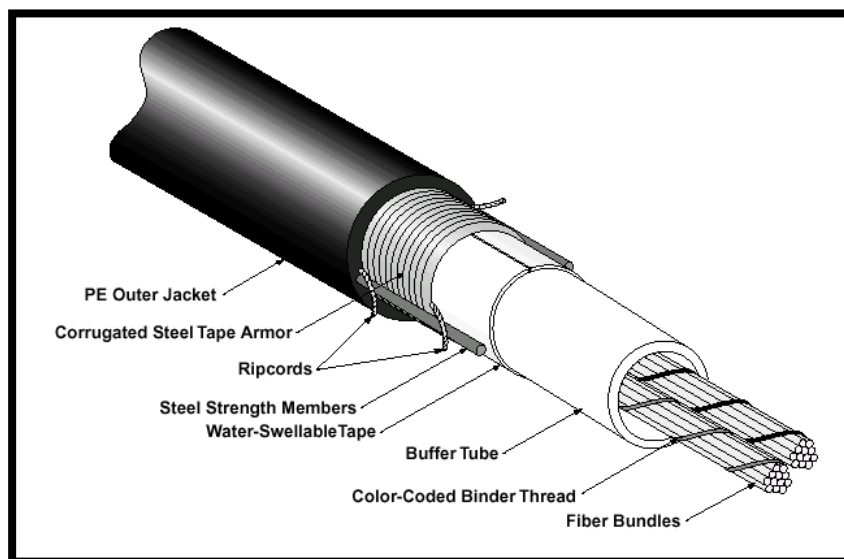

Figure 5 – Central Tube Cable (Bundled Fibers)

5.3 Figure-8

Figure-8 cables are composed of two distinct subcomponents. The first is an optical cable similar to the loose tube cables described previously. The second is a messenger wire connected to the cable by a plastic web. The cross section of this composite structure closely resembles the numeral “8”; hence, the source of the name. These cables are used in aerial applications. The basic components and properties of the cable portion are identical to those previously described for the stranded loose tube and central tube cable designs. The intent of this cable design is to combine the installation of the messenger wire and optical cable into a single process. An example of this type of cable structure is shown in Figure 6.

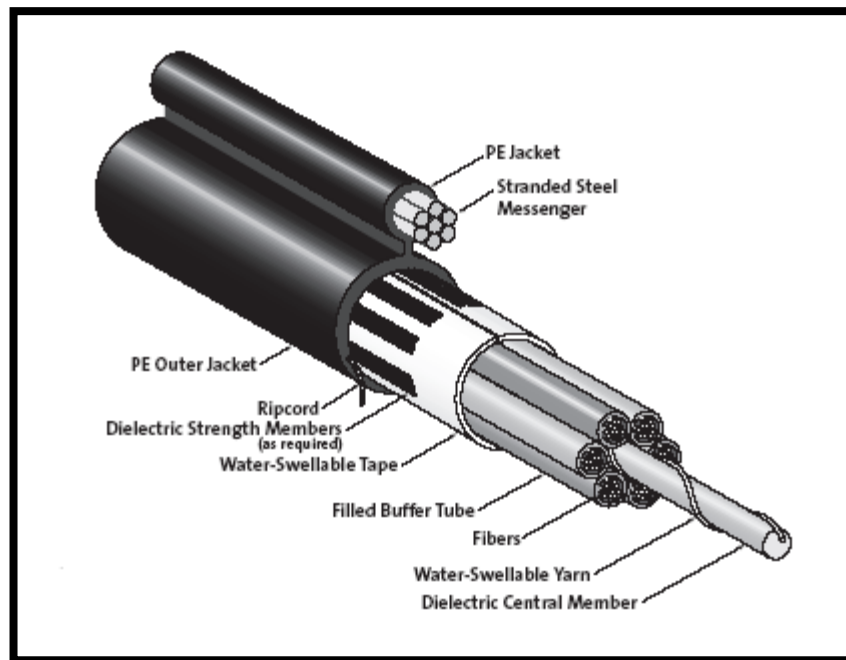

Figure 6 – Figure-8 Cable Design

5.4 All Dielectric Self Supporting (ADSS)

All Dielectric Self Supporting (ADSS) cables are a more recent design concept. These cables are designed to be installed in a single operation similar to Figure-8 cable; but, this cable design has a completely round cross section. This cable design has no electrically conductive elements which is sometimes a requirement when installing in close proximity to utility company power cables. The tensile strength for these cables is provided by a dielectric strength material (typically aramid yarn). The cable is safely supported aurally through the use of hardware specifically designed for this application that achieves coupling to the dielectric strength material and bears the weight of the cable. An example of this type of cable structure is shown in Figure 7.

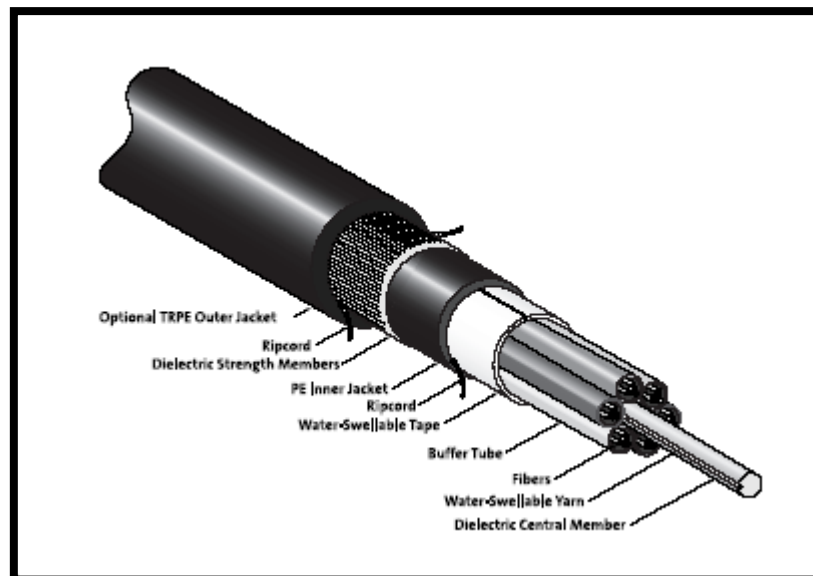

Figure 7 – All Dielectric Self Supporting (ADSS) Cable Design

6.0 PERFORMANCE REQUIREMENTS

OSP optical fiber cable shall meet the requirements of the ANSI/ICEA S-87-640 “*Standard for Optical Fiber Outside Plant Communications Cable.*” The most current ANSI/ICEA S-87-640 revision level shall be used. Only optical fiber cable constructions specified in this document shall be used for outside plant applications.

7.0 SELECTION GUIDE & APPLICATION CONSIDERATIONS

Cable selection involves many factors. To optimize matching the specific optical fiber/optical cable for a specific application, evaluating the following list of general considerations is a good starting point.

7.1 Fiber type

- Intended wavelength(s) of operation
- Maximum transmission distance
- Intended data rate

7.2 Fiber count

- Intended end user application requirements
- Future growth of network
- Physical network topology

7.3 Installation method

- If aerial, strand and lash
- If aerial, figure-8 self supported
- If aerial, all-dielectric self supported
- Direct buried
- Pulled into duct
- Special application

7.4 Cable Design

- Stranded loose tube or central tube
- Bundled fibers or ribbon
- Dielectric or armored

7.5 Application, Geographical, or Situation dependent

- What is the seasonal temperature range
- Close proximity to or placed in a body of water
- What is the historical lightning strike density
- Known rodent damage issues
- Installation in previously used or occupied conduit
- Over lash to previously installed aerial plant
- What are the NESC loading conditions for the location

Proper determination of the scope of the application, with the assistance of the general guidance above, will assist in the cable selection process. Employing proper due diligence, the system operator can select the best cable independently or consult a manufacturer for assistance. In either case, the application considerations outlined in this section represent significant information necessary to make an informed decision.