



***Society of Cable
Telecommunications
Engineers***

**ENGINEERING COMMITTEE
Interface Practices Subcommittee**

AMERICAN NATIONAL STANDARD

ANSI/SCTE 82 2007

**Test Method for Low Frequency
and Spurious Disturbances**

NOTICE

The Society of Cable Telecommunications Engineers (SCTE) Standards are intended to serve the public interest by providing specifications, test methods and procedures that promote uniformity of product, interchangeability and ultimately the long term reliability of broadband communications facilities. These documents shall not in any way preclude any member or nonmember of SCTE from manufacturing or selling products not conforming to such documents, nor shall the existence of such standards preclude their voluntary use by those other than SCTE members, whether used domestically or internationally.

SCTE assumes no obligations or liability whatsoever to any party who may adopt the Standards. Such adopting party assumes all risks associated with adoption of these Standards or Recommended Practices, and accepts full responsibility for any damage and/or claims arising from the adoption of such Standards or Recommended Practices.

Attention is called to the possibility that implementation of this standard may require use of subject matter covered by patent rights. By publication of this standard, no position is taken with respect to the existence or validity of any patent rights in connection therewith. SCTE shall not be responsible for identifying patents for which a license may be required or for conducting inquiries into the legal validity or scope of those patents that are brought to its attention.

Patent holders who believe that they hold patents which are essential to the implementation of this standard have been requested to provide information about those patents and any related licensing terms and conditions. Any such declarations made before or after publication of this document are available on the SCTE web site at <http://www.scte.org>.

All Rights Reserved

© Society of Cable Telecommunications Engineers, Inc. 2003, 2007

140 Philips Road

Exton, PA 19341

TABLE OF CONTENTS

| | | |
|-----|--|----|
| 1.0 | SCOPE AND DEFINITIONS | 1 |
| 2.0 | INFORMATIVE REFERENCES | 1 |
| 3.0 | EQUIPMENT | 1 |
| 4.0 | SETUP..... | 2 |
| 5.0 | PROCEDURE | 5 |
| 6.0 | APPENDIX 1 – SPECIAL TEST CONSIDERATIONS | 9 |
| 7.0 | APPENDIX 2 – MODULATION SIDEBAND LEVEL TO ACTUAL CARRIER LEVEL CORRECTION FACTOR (METHOD 1) | 10 |
| 8.0 | APPENDIX 3 – SIDEBAND LEVEL VS. PERCENT MODULATION ... | 11 |
| 9.0 | APPENDIX 4 – TEST REPORT | 12 |

1.0 SCOPE AND DEFINITIONS

1.1 Scope

To define and measure low frequency and spurious disturbances caused by switched mode power supplies or other active devices in broadband Cable Telecommunications equipment.

1.2 Definitions

1.2.1 Low Frequency and Spurious Disturbances: The result of unwanted harmonic components related to the switching rate of the power supply, or frequencies generated by other active components, which exceed the system noise level within and outside the Device Under Test (DUT) system passband.

1.2.2 Amplitude Modulation (AM) Distortion: Amplitude Modulation caused by the interaction of a carrier signal and an undesired Low Frequency or Spurious Disturbance present in the DUT. Spurious disturbances below 1 kHz can be more accurately measured using the procedure, ANSI/SCTE 16 2007 entitled, "Test Procedure for Hum Modulation". Possible dynamic range limitations in the measurement instruments used in this procedure could cause large errors for spurious signal levels which exist at frequencies closer than 1 kHz to the carrier.

2.0 INFORMATIVE REFERENCES

The following documents may provide valuable information to the reader but are not required when complying with this standard.

1. ANSI/SCTE 16 2007 Test Procedure for Hum Modulation
2. ANSI/SCTE 96 2003 Cable Telecommunications Testing Guidelines

3.0 EQUIPMENT

- 3.1 The general equipment required for this test is shown in Figures 1 and 2. It is described and specified in ANSI/SCTE 96 2003, Test Procedures Introduction.
- 3.2 SA (Spectrum Analyzer), minimum input frequency range of 5 MHz to 1.002 GHz.
- 3.3 BA (Baseband Analyzer), minimum input frequency range of 5 Hz to 10 MHz.

Note: A FFT (Fast Fourier Transform Analyzer) may be used, but the user must make certain that its input frequency range is sufficient to capture all significant

harmonics of the DUT power supply switching frequency.

A BA (or FFT) is only required if Method 1 for AM Distortion (see 4.3.1) is used.

- 3.4 SG (Signal Generator). If Method 1 for AM Distortion (see 4.3.1) is used, SG must be capable of TV (downward-only AM) square-wave modulation.
 - 3.5 BPF (Bandpass Filter(s)) for the frequencies under test
 - 3.6 Low-noise post-amplifier of known gain (if required – see 5.1.4, 5.2.7, and 5.3.6)
 - 3.7 AC/RF Power Inserter with sufficient current capability for the DUT and a minimum RF frequency range of 5 MHz to 1 GHz.
- Note: AC/RF Power Inserters may not be required under certain test conditions. Refer to Appendix 1 for special test considerations.
- 3.8 Cables, pads, terminations, and adapters as required.

4.0 SETUP

- 4.1 Follow all calibration requirements recommended by the manufacturers of the signal generator, SA, and BA (or FFT), including adequate warm-up and stabilization time.
- 4.2 Forward/Reverse Band Low Frequency and Spurious Disturbance Equipment Set-up.
 - 4.2.1 Connect the test equipment as shown in Figure 1.

Note: AC Power should be inserted into the output port of the DUT to obtain optimum isolation.

- 4.2.2 Configure the DUT with all appropriate fuses/power links in place. Ensure the test equipment is protected from AC by the power inserters or by utilizing AC-blocking adapters.

- 4.2.3 Terminate all unused ports of the DUT in its characteristic impedance. Protect the terminators from AC by removing fuses or links at the ports in question, or by using AC-blocking adapters.

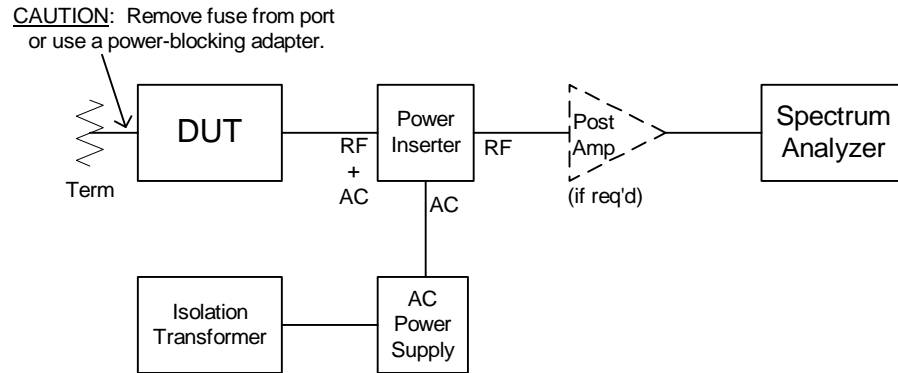

Figure 1 – Low Frequency and Spurious Disturbances Equipment Set-up

4.3 Amplitude Modulation (AM) Distortion Equipment Set-up.

- 4.3.1 Two test methods will be described. Method 1 measures the detected distortion with reference to 100% modulation. Method 2 measures the distortion sidebands with reference to the carrier level.

- 4.3.2 Connect the test equipment as shown in Figure 2, depending on the method to be used.

Note: AC Power should be inserted into the output port of the DUT to obtain optimum isolation.

- 4.3.3 Configure the DUT with all appropriate fuses/power links in place. Ensure the test equipment is protected from AC by the power inserters or by utilizing AC blocks.
- 4.3.4 Terminate all unused ports of the DUT in its characteristic impedance. Protect the terminators from AC by removing fuses or links at the ports in question, or by using AC-blocking adapters.
- 4.3.5 Set the appropriate signal levels for the carriers used during the test.

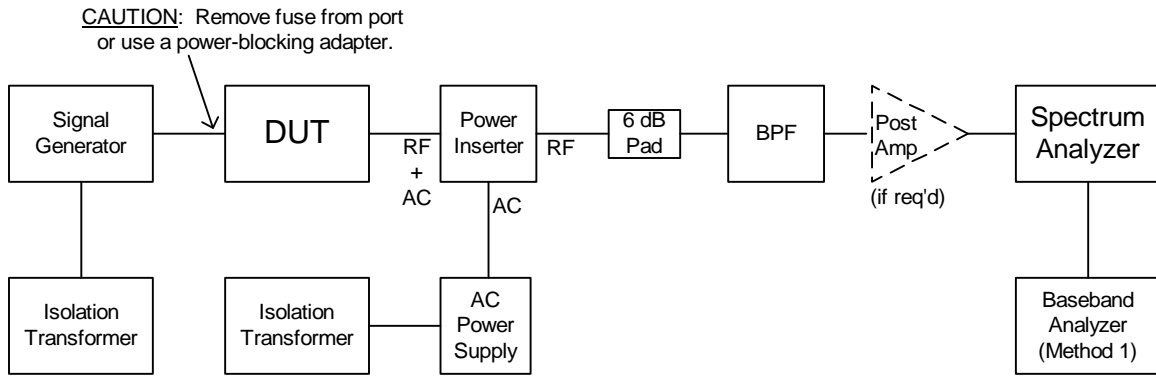

Figure 2 – Amplitude Modulation (AM) Distortion Equipment Set-up

5.0 PROCEDURE

5.1 Forward/Reverse Band Low Frequency and Spurious Disturbances

5.1.1 Set the SA to the settings indicated in Table 1.

Table 1

| | |
|----------------------------|-------------------|
| Start and Stop Frequencies | See 5.1.5 below |
| Resolution BW | 30 kHz (See note) |
| Video BW | 1 kHz |
| Input Attenuator | 0 dB |
| Scale | 10 dB/div |
| Sweep time | Auto |

Note: Several different resolution bandwidth settings may be used on the SA in order to properly identify areas within the DUT passband containing switching harmonic components. The resolution bandwidth of the SA should be adjusted so that the noise floor is below the Disturbances specification of the DUT.

5.1.2 Connect the DUT output to the SA

5.1.3 Power the DUT with the maximum specified AC input voltage.

5.1.4 Insure, by disconnecting and terminating the input to the SA, that the system noise floor is above the SA noise floor. If not, connect a post amplifier of known gain as shown in Figure 1.

5.1.5 Observe the SA display in 20 MHz increments over the following frequency ranges for any regions where spurious signals exceed flat system noise.

5.1.5.1 In the forward band, from 10 MHz below to 10 MHz above the specified passband of the DUT.

5.1.5.2 In the return band, from the minimum SA frequency to 10MHz above the specified passband of the DUT.

5.1.6 Measure and record all observed spurious signals by frequency and level. See Appendix 4 for a suggested report format.

5.1.7 Repeat steps 5.1.5 through 5.1.6 for all desired AC voltages and test temperatures.

5.2 Amplitude Modulation (AM) Distortion, Method 1 (100% modulation reference)

5.2.1 Connect the SG output to the appropriate port of the DUT, and the DUT output to the 6 dB pad.

5.2.2 Power the DUT with the maximum specified AC input voltage.

5.2.3 Set the SG for a specified carrier frequency.

5.2.4 Set the SA to the settings indicated in Table 2.

Table 2

| | |
|------------------|--------------------------|
| Center Frequency | (Carrier under test) MHz |
| Frequency Span | 20 MHz |
| Resolution BW | 1 MHz |
| Video BW | 1 MHz |
| Scale | Linear |
| Sweep Time | 10 sec min |

5.2.5 Set the BA to the settings indicated in Table3.

Table 3

| | |
|-------------------|------------------|
| Start Frequency | Min BA frequency |
| Stop Frequency | 500 kHz |
| Resolution BW | 10 kHz |
| Scale | Logarithmic |
| Sweep Time / Mode | Auto (linear) |

5.2.6 Center the BPF on the desired test frequency.

5.2.7 Insure, by disconnecting and terminating the input to the SA, that the system noise floor is above the SA noise floor. If not, connect a post amplifier of known gain as shown in Figure 2.

5.2.8 In order to obtain a reference value, modulate the test carrier with a 15.75 kHz square wave, 50% duty cycle, 100% (downward) modulation.

5.2.9 Adjust the SA Frequency Span to 0 MHz and adjust the reference level on the SA to obtain full screen deflection of the modulated test carrier.

5.2.10 Set the BA marker to the peak of the detected modulation signal at 15.750 kHz. Record this level as S_L , Sideband Level.

- 5.2.11 Turn off the modulation on the test carrier.
- 5.2.12 Using the marker delta function on the BA, record the level of any observed switching frequency-generated distortion as D_L , Disturbance Level.
- 5.2.13 Record uncorrected switching frequency and harmonic AM distortion in dB down (expressed in negative dB) as:

$$\text{Uncorrected Value (-dB)} = S_L \text{ (dB)} - D_L \text{ (dB)}$$

- 5.2.14 Subtract 3.9 dB from the uncorrected level to obtain the corrected distortion level (See Appendix 2 for details):

$$\text{Corrected Value (-dB)} = \text{Uncorrected Value (-dB)} - 3.9 \text{ dB}$$

Example: If Uncorrected Value = -68 dB

$$\text{Corrected Value} = -68 \text{ dB} - 3.9 \text{ dB} = -71.9 \text{ dB}$$

See Appendix 4 for a suggested report format.

- 5.2.15 Reduce the BA Stop Frequency to 10 kHz and the Resolution BW to 30 Hz.
- 5.2.16 Using the marker delta function on the BA, record the level of any observed power line frequency and harmonic AM distortion as D_L , Disturbance Level.
- 5.2.17 Make corrections and record results as described in 5.2.13 and 5.2.14.
- 5.2.18 Repeat steps 5.2.2 through 5.2.17 for all desired AC input voltages, test frequencies, signal levels, and temperatures.

5.3 Amplitude Modulation (AM) Distortion, Method 2 (Carrier Level Reference)

- 5.3.1 Connect the SG output to the appropriate port of the DUT, and the DUT output to the 6 dB pad.
- 5.3.2 Power the DUT with the maximum specified AC input voltage.
- 5.3.3 Set the SG for a specified carrier frequency.
- 5.3.4 Set the SA to the settings indicated in Table 4.

Table 4

| Center Frequency | (Carrier under test) MHz |
|------------------|--------------------------|
| Frequency Span | 3 MHz |
| Resolution BW | 10 kHz |
| Video BW | 1 kHz |
| Scale | 10 dB/div |
| Sweep Time | Auto |

- 5.3.5 Center the BPF on the desired test frequency.
 - 5.3.6 Insure, by disconnecting and terminating the input to the SA, that the system noise floor is above the SA noise floor. If not, connect a post amplifier of known gain as shown in Figure 2.
 - 5.3.7 Adjust the reference level on the SA to obtain full screen deflection of the test carrier.
 - 5.3.8 Measure and record the carrier frequency and any observed switching frequency and harmonic sideband levels. See Appendix 4 for a suggested report format.
 - 5.3.9 Reduce the Frequency Span to 10 kHz, the Resolution BW to 30 Hz, and the Video BW to 10 Hz.
 - 5.3.10 Measure and record the carrier frequency and any observed power line frequency and harmonic sideband levels.
- NOTE: Depending on the instrument used, better results for power line frequency and harmonic AM distortion may be gotten with Method 1.
- 5.3.11 Repeat steps 5.3.2 through 5.3.10 for all desired AC input voltages, test frequencies, signal levels, and temperatures.

6.0 APPENDIX 1 – SPECIAL TEST CONSIDERATIONS

The test setup and procedure in this document detail a test methodology that is specific to devices in which the power enters and exits on the RF test ports. However, some test devices do not have this arrangement. Drop amplifiers are examples of devices that do not contain two RF/power ports. Typical configurations of drop amplifiers include use of only one RF/power port, or a dedicated power port and stand-alone (no power passing capability) RF ports.

Under circumstances such as the ones listed above, this procedure can be followed with minor test set-up modifications. Obviously, if one or more RF ports of the DUT do not contain power passing capability, the precautions regarding removal of fuses or use of AC-blocking adapters are not required for those ports.

For example, a DUT containing only one RF/power port would be tested using an AC/RF power inserter on the RF/power port, and an RF only connection on the other port. A DUT containing a dedicated powering port would not require AC/RF power inserters/combiners on the test ports, as they are not meant to pass power.

It should also be noted that, in cases where the only RF/power port is an input (either forward or reverse path), the suggestion that power be inserted into the output port can, obviously, not be followed.

A general rule of thumb when performing this test is to utilize RF/AC power inserters on any DUT port that shares RF and power passing capability. Otherwise, direct connections should be used. The procedure can be followed as stated with these minor changes to the test set-up.

7.0 APPENDIX 2 – MODULATION SIDEBAND LEVEL TO ACTUAL CARRIER LEVEL CORRECTION FACTOR (METHOD 1)

3.9 dB must be subtracted from the measured switching frequency-generated AM sideband in order to accurately relate the square wave reference modulation to the carrier level under test. The modulation sideband recorded as S_L is the first harmonic of the 15.750 kHz signal as detected by the BA or FFT. With the SG utilizing switched modulation at 15.750 kHz, the equation for this switched modulation signal is:

$$m(t) = \frac{1}{2} + \frac{2}{\pi} \left(\cos \omega_m t - \frac{1}{3} \cos 3\omega_m t + \frac{1}{5} \cos 5\omega_m t - \dots \right) \quad (\text{A-1})$$

The first cosine term in A-1 is the first harmonic. If the other harmonic components are removed for example purposes, equation A-1 becomes:

$$m(t) = \frac{1}{2} + \frac{2}{\pi} (\cos \omega_m t) \quad (\text{A-2})$$

The test carrier, which is CW, can be shown as:

$$f(t) = \cos \omega_c t \quad (\text{A-3})$$

When the test carrier is modulated by the switched modulation signal described in A-2, and $f(t) = 1$, the resultant signal can be shown as:

$$f(t)m(t) = \frac{1}{2} f(t) + \frac{2}{\pi} [f(t) \cos \omega_m t] \quad (\text{A-4})$$

The first harmonic maximum peak occurs at $\omega_m t = 0$ radians, and the first harmonic minimum peak occurs at $\omega_m t = \pi$ radians. Therefore, if equation A-4 is used to calculate the maximum and minimum harmonic peaks, the results are:

$$\text{Maximum} = f(t)m(t) = \frac{1}{2}(1) + \frac{2}{\pi} [(1) \cos 0] = 1.137 \quad (\text{A-5})$$

$$\text{Minimum} = f(t)m(t) = \frac{1}{2}(1) + \frac{2}{\pi} [(1) \cos \pi] = -0.137 \quad (\text{A-6})$$

The ratio, in dB, for the first harmonic signal detected on the BA or FFT to the actual test carrier level can be determined as:

$$20\text{Log} \left(\frac{\text{Max}(1st\ Harmonic) - \text{Min}(1st\ Harmonic)}{\text{Max}(CW\ Signal) - \text{Min}(CW\ Signal)} \right) = 20\text{Log} \left(\frac{1.137 - (-0.137)}{1.0 - (-1.0)} \right) = -3.9\text{dB} \quad (\text{A-7})$$

Therefore, the correction factor to apply in order to obtain the measurement from the actual carrier level to the disturbance level is -3.9 dB.

8.0 APPENDIX 3 – SIDEBAND LEVEL VS. PERCENT MODULATION

Although this Standard tests for AM distortion in terms of sideband levels relative to 100% modulation (Method 1) or to the unmodulated carrier (Method 2), AM distortion levels are sometimes specified as modulation percentages. This appendix will review the relationships between sideband level and modulation depth, particularly as applied to the type of modulation used in normal analog television.

Television video modulation is commonly referred to as “downward only”. The modulating signal contains a DC component, so that the modulation peaks of one polarity are at the same level as the unmodulated carrier, while the opposite polarity modulation reduces the carrier level toward zero. “Conventional” AM, on the other hand, increases the carrier level on peaks of one polarity and decreases it on opposite peaks. Thus, at 100% modulation a TV signal will have half the peak-to-peak amplitude as the same carrier with conventional AM.

From this we can deduce that a SA display will show 6 dB less sideband amplitude from TV modulation than from conventional AM for the same carrier level and modulation percentage. Conversely, a given sideband level represents twice the modulation percentage in TV terms as in conventional AM.

The conventional AM sideband-to-modulation percentage conversion is:

$$\%M = 200 \times 10^{\left(\frac{-dB}{20}\right)} \quad (A-8)$$

but if expressed in terms of TV modulation:

$$\%M = 400 \times 10^{\left(\frac{-dB}{20}\right)} \quad (A-9)$$

where “dB” is the difference between the sideband level and the unmodulated carrier. (For conventional AM, the carrier level as displayed on the SA does not change with modulation. However, for asymmetrical AM this is not true, hence the unmodulated carrier must be used as the reference.)

AM distortions can be created within equipment as conventional AM, but will not necessarily have perfect amplitude symmetry relative to the unmodulated carrier. However, it has been a long-standing convention to refer the disturbance level to the unmodulated carrier level as if the phenomenon were purely TV modulation. For example, sidebands 40 dB below the unmodulated carrier level would correspond to 2% conventional AM modulation (using A-8), but (using A-9) we would express it in terms of TV modulation as 4%.

AM Distortion Method 2 (carrier level reference)

Unit under test

| | | | |
|-----------------|--|----------------|--|
| Equipment Type: | | Manufacturer: | |
| Model Number: | | Serial number: | |

Test equipment

| Description | Manufacturer | Model Number | Serial Number | Calibration Date |
|-------------|--------------|--------------|---------------|------------------|
| | | | | |
| | | | | |
| | | | | |
| | | | | |
| | | | | |
| | | | | |
| | | | | |
| | | | | |
| | | | | |
| | | | | |
| | | | | |

Test Results

| Frequency (MHz) | Spurious Disturbance (dBmV) |
|-----------------|-----------------------------|
| | |
| | |
| | |
| | |
| | |
| | |
| | |
| | |
| | |
| | |

| Frequency (MHz) | AM. Distortion (dBc) |
|-----------------|----------------------|
| | |
| | |
| | |
| | |
| | |
| | |
| | |
| | |
| | |
| | |

| | |
|-----------|------|
| Tested by | Date |
| | |