



***Society of Cable
Telecommunications
Engineers***

**ENGINEERING COMMITTEE
Interface Practices Subcommittee**

AMERICAN NATIONAL STANDARD

ANSI/SCTE 102 2010

**Cable Retention Force Testing of
Trunk & Distribution Connectors**

NOTICE

The Society of Cable Telecommunications Engineers (SCTE) Standards are intended to serve the public interest by providing specifications, test methods and procedures that promote uniformity of product, interchangeability and ultimately the long term reliability of broadband communications facilities. These documents shall not in any way preclude any member or non-member of SCTE from manufacturing or selling products not conforming to such documents, nor shall the existence of such standards preclude their voluntary use by those other than SCTE members, whether used domestically or internationally.

SCTE assumes no obligations or liability whatsoever to any party who may adopt the Standards. Such adopting party assumes all risks associated with adoption of these Standards, and accepts full responsibility for any damage and/or claims arising from the adoption of such Standards.

Attention is called to the possibility that implementation of this standard may require the use of subject matter covered by patent rights. By publication of this standard, no position is taken with respect to the existence or validity of any patent rights in connection therewith. SCTE shall not be responsible for identifying patents for which a license may be required or for conducting inquiries into the legal validity or scope of those patents that are brought to its attention.

Patent holders who believe that they hold patents which are essential to the implementation of this standard have been requested to provide information about those patents and any related licensing terms and conditions. Any such declarations made before or after publication of this document are available on the SCTE web site at <http://www.scte.org>.

All Rights Reserved

© Society of Cable Telecommunications Engineers, Inc. 2010
140 Philips Road
Exton, PA 19341

TABLE OF CONTENTS

1.0	SCOPE	1
2.0	EQUIPMENT	1
3.0	TEST SAMPLE PREPARATION.....	3
4.0	TEST PROCEDURE	5
5.0	TEST DATA & DOCUMENTATION.....	6
6.0	GLOSSARY OF TERMS	8

1.0 SCOPE

- 1.1 The purpose of this document is to define a standard test procedure to prepare, test and document the retention forces of a given connector/cable assembly, as whole or separate components.
- 1.2 This test is intended to determine the tensile forces required to cause one or more of the following conditions in a connector/cable assembly under test:
 - Catastrophic cable structural failure.
 - Connector structural failure.
 - Separation due to slip at the connector/cable interface.

2.0 EQUIPMENT

- 2.1 A tensile test machine (Example- Instron Model 1156) or an equivalent system of separate components that provide the following:
 - 2.1.1 Equipment must be adequate for the load being tested with a system accuracy of ± 0.5 percent.
 - 2.1.2 A movable crosshead capable of constant travel at 2 inches/minute
 - 2.1.3 Chart recorder or similar feature capable of providing a plot of crosshead extension vs. load.
- 2.2 Appropriate adapters to connect test sample between crosshead and base. See Figure 1 for typical connector adapter.
- 2.3 Cable and Connectors
- 2.4 Cable Preparation & Installation Tools
- 2.5 Applicable Safety Equipment (Safety Glasses, Equipment Guards, etc., as required)

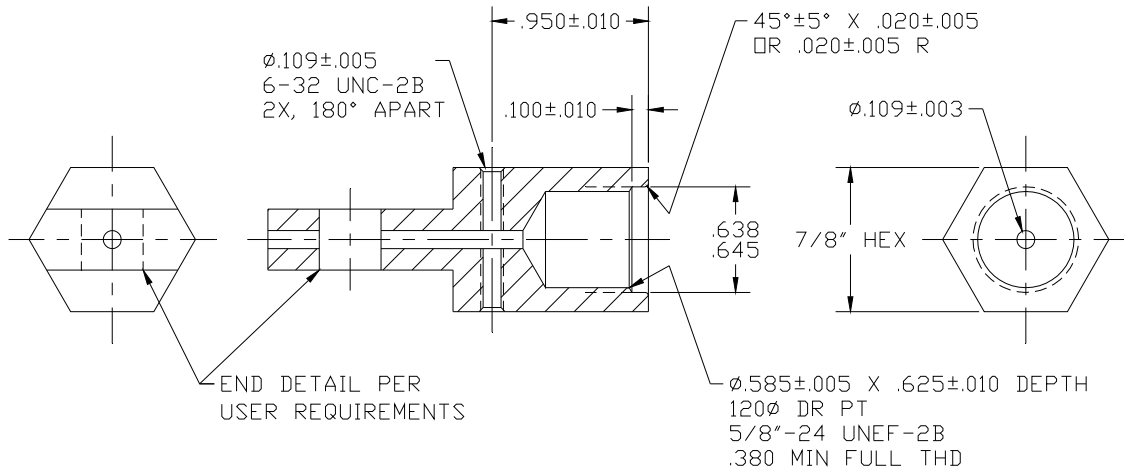

Figure 1: Typical Test Fixture

Note: Supply each test fixture with two #6-32 x 3/8" long Hex Socket, Cup Point Set Screws.

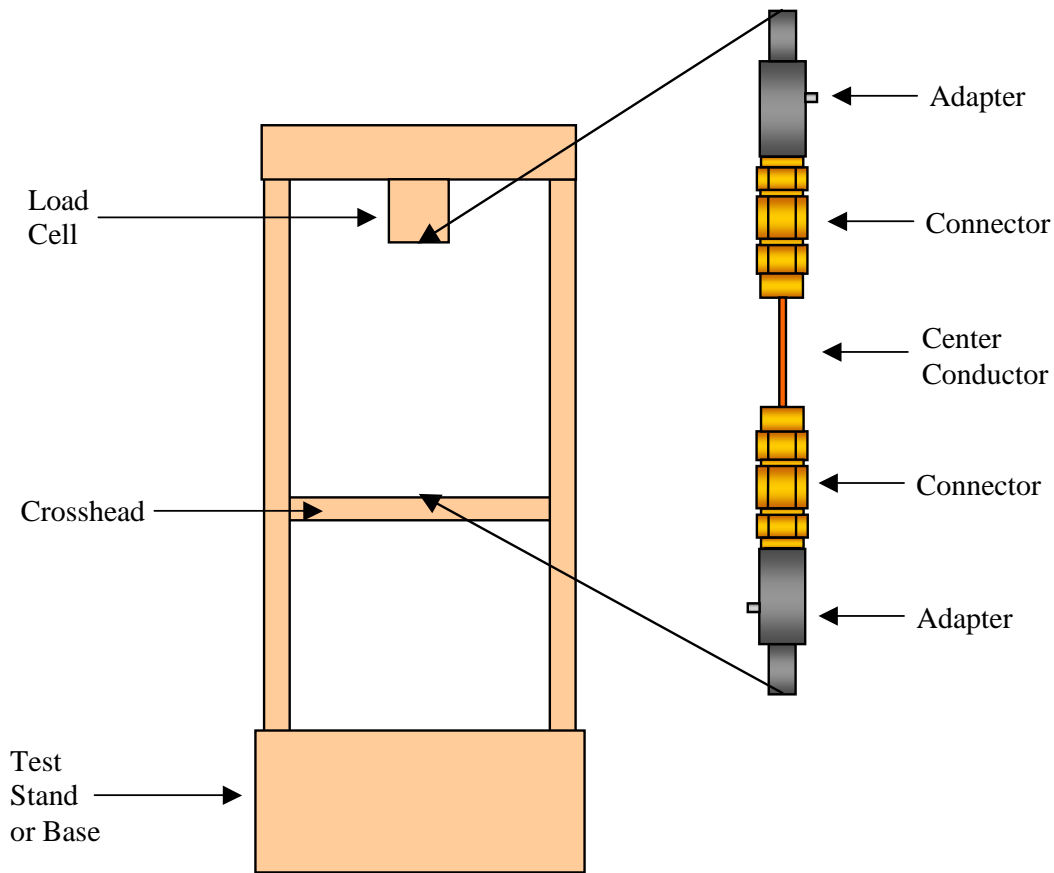

Figure 2: Diagram of a Typical Test Stand & Device Under Test

Note: Equipment varies. The load cell of some test stands may be affixed to the crosshead.

3.0 TEST SAMPLE PREPARATION

3.1 Center Conductor to Pin Connector

- 3.1.1 Prepare a four-inch (4") minimum length of center conductor with all dielectric removed.

Note: It may be necessary to prepare an additional section of cable outer conductor (shield) and jacket (if applicable) with the center conductor and dielectric removed. Position the cable shield (and jacket if applicable) into the connector back nut assembly. Ensure this section of cable does not interfere

with the center conductor gripping mechanism of the tensile test equipment and/or connector.

- 3.1.2 Using the connector manufacturer's recommended tightening procedures, install and tighten prepared center conductor into a connector.
- 3.1.3 Select appropriate test fixture to grip center conductor, or prepare a second pin connector as shown in the diagram below.
- 3.1.4 Attach test fixtures (adapters) to the Pin connector(s) (or center conductor) as required. Secure connector center conductor pin to fixture prior to testing to prevent pin movement.

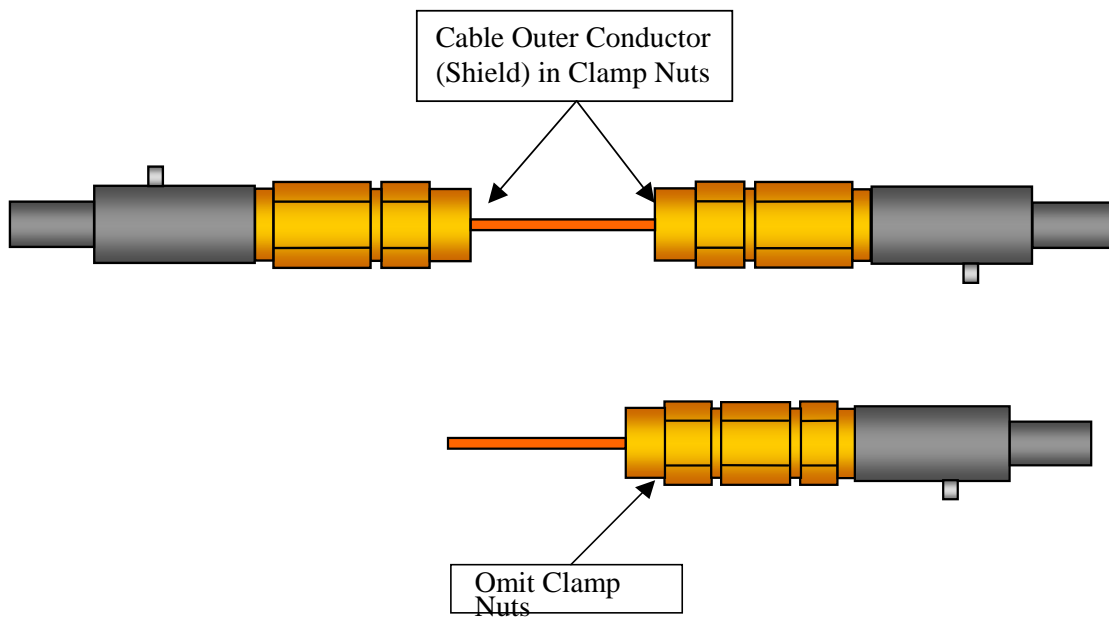

Figure 3: Test Sample Configuration, Center Conductor Pull

3.2 Outer Conductor* (Shield) to Pin Connector

- 3.2.1 Prepare an appropriate length of cable using cable preparation tools as recommended by the connector and/or cable manufacturer.
- 3.2.2 Cut the center conductor of cable flush with the end of the Outer Conductor* (Shield).
- 3.2.3 Install prepared cable into the connector under test using the connector manufacturer's recommended installation procedures.
- 3.2.4 Select appropriate test fixture to grip cable outer conductor, or prepare a second pin connector as shown in Figure 3 below.
- 3.2.5 Attach test fixtures (adapters) to the Pin connectors(s) or cable as required.

* May include flooding compounds and cable jacket.

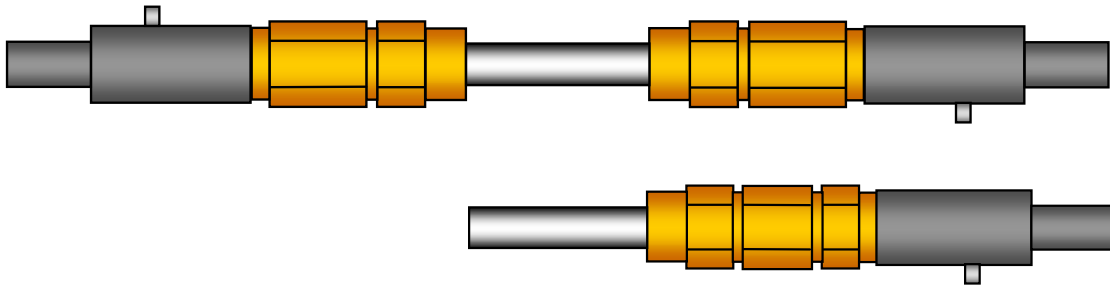

Figure 4: Test Sample Configuration, Outer Conductor Pull

3.3 Combined Center Conductor and Outer Conductor* (Shield) to Pin Connector

- 3.3.1 Prepare an appropriate length of cable using cable preparation tools as recommended by the connector and/or cable manufacturer.
- 3.3.2 Install prepared cable into the connector under test using the connector manufacturer's recommended installation procedures.
- 3.3.3 Select appropriate test fixture to grip the cable, or prepare a second pin connector as shown in Figure 4 below.
- 3.3.4 Attach test fixtures (adapters) to the Pin connectors(s) or cable as required.
 - May include flooding compounds and cable jacket.

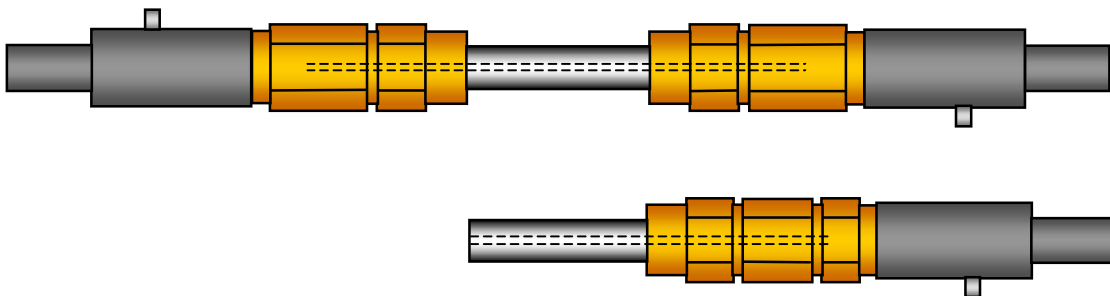

Figure 5: Test Sample Configuration, Combined Conductor Pull

4.0 TEST PROCEDURE

WARNING! PROCEED WITH CAUTION! Failure to follow test equipment operational instruction could result in serious bodily injury or property damage!

- 4.1 Verify that the units under test are at the specified test temperature prior to performing any tests.
- 4.2 Install the DUT into the tensile test system using the necessary fixtures, adaptors and anchor pins. Caution: Use extreme care to avoid personal injury and/or damage to equipment.
- 4.3 Zero the force and extension settings as required.
- 4.4 Engage the recording device (if applicable).
- 4.5 Initiate the test sequence.
- 4.6 Conclude the test once the desired effect has been achieved.
- 4.7 Disengage the recording device (if applicable).

5.0 TEST DATA & DOCUMENTATION

- 5.1 Inspect test samples as required.
- 5.2 The results of the test shall be documented.
- 5.3 Test Data

5.3.1 CABLE DESCRIPTION

5.3.1.1 Cable Manufacturer/Part Number _____

5.3.1.2 Cable Type _____

5.3.2 CONNECTOR DESCRIPTION

5.3.2.1 Connector Manufacturer/Part Number _____

5.3.3 CABLE PREP DESCRIPTION

5.3.3.1 Prep Tool Used _____

5.3.3.2 Hex Flat Dimensions (if applicable)

1) _____ 2) _____ 3) _____

5.3.4 TEST SETUP DESCRIPTION

Crosshead Speed	Full Scale Load	Test Temperature

5.3.5 AXIAL LOAD

Sample	Maximum Load
1	
2	
3	
4	
5	
6	
7	
8	
9	
10	
Average	

6.0 GLOSSARY OF TERMS

- 6.1 Test Stand – The physical device to mechanically perform a tensile/compressive test.
- 6.2 Chart Recorder – A device for plotting test results such as stress-strain curves.
- 6.3 RS232 Link – A computer output port capable of sending actual test data to a remote computer with data acquisition equipment, for processing with data analysis software
- 6.4 DUT - Device under Test, also referred to as specimen or sample.
- 6.5 Load Cell - A calibrated, sensitive and precision device attached to one end of the test stand that converts tensile or compressive energy into electrical signals for the Chart Recorder or Data Acquisition Unit.
- 6.6 Adaptors/Fixtures - A mechanical device typically located between the test stand Load Cell or Crosshead and the DUT
- 6.7 Stress – is force per unit area in pounds per square inch (psi). If stress lengthens or stretches material, it is called tensile stress.
- 6.8 Strain – is the amount by which a dimension of a device changes when subjected to a load, divided by the original value of the dimension
- 6.9 Proportional Limit – the point on a stress-strain curve at which the DUT begins to deviate from the straight-line relationship between stress and strain.
- 6.10 Elastic Limit – the maximum stress a DUT is subjected to and will return to its original length once the load is released.
- 6.11 Yield Point – A point on the stress-strain curve with a sudden increase in strain without a corresponding increase in the stress.
- 6.12 Ultimate Strength – Or Tensile Strength, is the maximum stress value obtained on a stress-strain curve.
- 6.13 Center Conductor – The centermost portion of coaxial cable, typically consisting of solid copper, copper clad aluminum, or other conductive wire.
- 6.14 Dielectric – The insulating and support material between the outer surface of the center conductor and the inside surface of the outer conductor (shield).
- 6.15 Outer Conductor (Shield) – the outermost portion of coaxial cable, typically consisting of copper, aluminum, or other conductive material.
- 6.16 Flooding Compound – A material or substance placed between the outer conductor (shield) and the inside surface of the cable jacket to provide protection to the coaxial cable.

- 6.17 Cable Jacket – The material covering the outer conductor (shield) to provide environmental and physical protection.
- 6.18 Pin Connector – A device to interface coaxial RF cable to equipment.
- 6.19 Splice Connector – A device to interface two pieces of coaxial RF cable.
- 6.20 Two Piece Connector – Typically incorporates an pin body and a back nut.
- 6.21 Three Piece Connector – Typically incorporates an pin body, center nut and back nut.