



***Society of Cable
Telecommunications
Engineers***

**ENGINEERING COMMITTEE
Hybrid Management Sub-Layer Subcommittee**

AMERICAN NATIONAL STANDARD

ANSI/SCTE 25-3 2005

**Hybrid Fiber Coax Outside Plant Status Monitoring –
Power Supply to Transponder Interface Bus (PSTIB)
Specification v1.1**

NOTICE

The Society of Cable Telecommunications Engineers (SCTE) Standards are intended to serve the public interest by providing specifications, test methods and procedures that promote uniformity of product, interchangeability and ultimately the long term reliability of broadband communications facilities. These documents shall not in any way preclude any member or nonmember of SCTE from manufacturing or selling products not conforming to such documents, nor shall the existence of such standards preclude their voluntary use by those other than SCTE members, whether used domestically or internationally.

SCTE assumes no obligations or liability whatsoever to any party who may adopt the Standards. Such adopting party assumes all risks associated with adoption of these Standards or Recommended Practices, and accepts full responsibility for any damage and/or claims arising from the adoption of such Standards or Recommended Practices.

Attention is called to the possibility that implementation of this standard may require use of subject matter covered by patent rights. By publication of this standard, no position is taken with respect to the existence or validity of any patent rights in connection therewith. SCTE shall not be responsible for identifying patent for which a license may be required or for conducting inquiries into the legal validity or scope of those patents that are brought to its attention.

All Rights Reserved

Published by

Society of Cable Telecommunications Engineers, Inc.
140 Philips Road
Exton, PA 19341
USA

TABLE OF CONTENTS

LIST OF FIGURES	IV
LIST OF TABLES	V
DOCUMENT HISTORY	VI
1 INTRODUCTION.....	1
1.1 SCOPE	1
1.2 TRANSPONDER TYPE CLASSIFICATIONS	2
1.3 HMS REFERENCE ARCHITECTURE FORWARD AND RETURN CHANNEL SPECIFICATIONS .	3
1.4 HMS SPECIFICATION DOCUMENTS	4
2 POWER SUPPLY TO TRANSPONDER INTERFACE BUS SPECIFICATION OVERVIEW.....	5
2.1 INTERFACE COMPLIANCE.....	5
2.2 IMPLEMENTATION COMPLIANCE	5
2.3 REVISION CONTROL.....	5
3 POWER SUPPLY TO TRANSPONDER INTERFACE BUS - PHYSICAL LAYER SPECIFICATION.....	6
3.1 INTERFACE REQUIREMENTS	6
3.1.1 <i>Connector Type</i>	6
3.1.2 <i>Communications Interface</i>	6
3.1.3 <i>Connector Signals</i>	6
3.1.4 <i>Transponder Power</i>	7
3.1.5 <i>Line Balance</i>	7
3.1.5.1 <i>Monitored Equipment</i>	7
3.1.5.2 <i>Transponder</i>	8
3.1.6 <i>Cable Length</i>	8
3.1.7 <i>Data Encoding</i>	8
3.1.8 <i>Bit Rate</i>	8
3.1.9 <i>Duplex</i>	8
3.1.10 <i>Method of Communications</i>	8
3.1.11 <i>Indicators</i>	8
3.2 INTERFACE DIAGRAM	8
4 POWER SUPPLY TO TRANSPONDER INTERFACE BUS – DATA LINK LAYER SPECIFICATION.....	10
4.1 DLL PACKET STRUCTURE	10
4.1.1 <i>Start</i>	10
4.1.2 <i>Destination Address</i>	10
4.1.3 <i>Source Address</i>	11
4.1.4 <i>Identification</i>	11

4.1.5	<i>Datagram</i>	11
4.1.6	<i>End</i>	12
4.1.7	<i>Checksum</i>	12
4.2	DLE SEQUENCE.....	12
4.3	INTERFACE TIMING.....	13
4.3.1	<i>Message Synchronization and Interaction</i>	13
4.3.2	<i>Transmission Timing Requirements</i>	13
4.3.2.1	Requirements for PRIMARY and SECONDARY Devices.....	14
4.4	DLL DATAGRAMS.....	16
4.4.1	<i>Structure</i>	16
4.4.1.1	Command/Response.....	16
4.4.1.2	Size of Data.....	16
4.4.1.3	Variable Binding.....	16
4.4.2	<i>Resolution Versus Accuracy</i>	17
4.4.3	<i>DLL Datagram Types</i>	17
4.4.3.1	Command: Get_Configuration.....	18
4.4.3.2	Response: Get_Configuration.....	18
4.4.3.2.1	Power Supplies.....	20
4.4.3.2.2	Generators.....	23
4.4.3.3	Command: Get_Power_Supply_Data.....	24
4.4.3.4	Response: Get_Power_Supply_Data.....	24
4.4.3.4.1	Battery Naming Conventions.....	27
4.4.3.5	Command: Power_Supply_Control.....	28
4.4.3.6	Command: Get_Generator_Data.....	28
4.4.3.7	Response: Get_Generator_Data.....	29
4.4.3.8	Command: Generator_Control.....	30
4.4.3.9	Response: Invalid_Request.....	31
4.4.3.10	Response: Request_Processed.....	32
	REFERENCES	33
	APPENDIX A. GLOSSARY	34
	APPENDIX B. LIST OF ACRONYMS	35
	APPENDIX C. REVISION TRACKING	36

LIST OF FIGURES

FIGURE 1: HMS REFERENCE ARCHITECTURE DIAGRAM	3
FIGURE 2: SAMPLE PSTIB RS-485 INTERFACE	9
FIGURE 3: DLL PACKET STRUCTURE	10
FIGURE 4: PSTIB DATA AND TIMING DIAGRAM	14
FIGURE 5: DLL DATAGRAM STRUCTURE.....	16
FIGURE 6: BATTERY STRING NAMING CONVENTIONS.....	27

LIST OF TABLES

TABLE 1: TRANSPONDER TYPE CLASSIFICATIONS	2
TABLE 2: HMS DOCUMENT FAMILY	4
TABLE 3: RJ-45 CONNECTOR PIN ASSIGNMENT	6
TABLE 4: SAMPLE PSTIB RS-485 INTERFACE – REFERENCE SIGNALS	9
TABLE 5: GENERIC DLL PACKET STRUCTURE	10
TABLE 6: RESERVED DESTINATION ADDRESS RANGES	11
TABLE 7: PSTIB TIMING SPECIFICATIONS	14
TABLE 8: GENERIC DLL DATAGRAM STRUCTURE	16
TABLE 9: DLL DATAGRAMS	17
TABLE 10: COMMAND: GET_CONFIGURATION DATAGRAM	18
TABLE 11: RESPONSE: GET_CONFIGURATION DATAGRAM	18
TABLE 12: RESPONSE: GET_CONFIGURATION DATAGRAM¹ VARIABLE BINDING (GENERAL)	19
TABLE 13: RESPONSE: GET_CONFIGURATION DATAGRAM^{1,2} VARIABLE BINDING (POWER SUPPLY)	20
TABLE 14: RESPONSE: GET_CONFIGURATION DATAGRAM¹ VARIABLE BINDING (GENERATOR)	23
TABLE 15: COMMAND: GET_POWER_SUPPLY_DATA DATAGRAM	24
TABLE 16: RESPONSE: GET_POWER_SUPPLY_DATA DATAGRAM	24
TABLE 17: RESPONSE: GET_POWER_SUPPLY_DATA DATAGRAM VARIABLE BINDING	24
TABLE 18: COMMAND: POWER_SUPPLY_CONTROL DATAGRAM	28
TABLE 19: COMMAND: GET_GENERATOR_DATA DATAGRAM	28
TABLE 20: RESPONSE: GET_GENERATOR_DATA DATAGRAM	29
TABLE 21: RESPONSE: GET_GENERATOR_DATA DATAGRAM VARIABLE BINDING	29
TABLE 22: COMMAND: GENERATOR_CONTROL DATAGRAM	30
TABLE 23: RESPONSE: INVALID_REQUEST DATAGRAM	31
TABLE 24: RESPONSE: REQUEST_PROCESSED DATAGRAM	32

DOCUMENT HISTORY

Status:	Proposed	Preliminary	Adopted	Approved
Owner:	SCTE Hybrid Management Sub-Layer Subcommittee			
History:				
v1.0				
7-31-01	☐ Released to HMS Subcommittee for consensus body balloting.			
8-30-01	☐ Adopted by HMS Subcommittee after consensus body balloting.			
10-03-01	☐ Released to SCTE Engineering Committee for consensus balloting.			
v1.1				
12-30-04	☐ Submitted to HMS subcommittee for review.			

1 Introduction

The Hybrid Fiber Coax (HFC) Outside Plant (OSP) Power Supply to Transponder Interface Bus (PSTIB) Specification is part of the suite of specifications developed by the Hybrid Management Sub-Layer (HMS) subcommittee under the SCTE. The purpose of the HMS specifications is to support the design and implementation of interoperable management systems for evolving HFC cable networks. The HMS Power Supply to Transponder Interface Bus (PSTIB) Specification describes the physical (PHY) interface and related messaging and protocols implemented at the Data Link Layer (DLL), Layers 1 and 2 respectively in the 7-layer ISO-OSI reference model, that support communications between HMS-compliant transponders and the managed OSP power supplies and other related power equipment to which they interface.

1.1 Scope

This specification describes the PSTIB PHY and DLL layer requirements and protocols that must be implemented to support reliable communications between all *Type 2* and *Type 3* compliant OSP HMS transponders on the HFC plant and managed OSP power supplies and related hardware. Any exceptions to compliance with this specification will be specifically noted in this document as necessary. Refer to **Table 1** for a full definition of the Type Classifications.

1.2 Transponder Type Classifications

Transponder type classifications referenced within the HMS suite of specifications are defined in **Table 1**.

Table 1: Transponder Type Classifications

Type	Description	Application
<i>Type 0</i>	Refers to legacy transponder equipment which is incapable of supporting the HMS specifications.	<ul style="list-style-type: none"> • This transponder interfaces with legacy network equipment through proprietary means. • This transponder could be managed through the same management applications as the other types through proxies or other means at the headend.
<i>Type 1</i>	Refers to stand-alone transponder equipment (legacy or new) which can be upgraded to support the HMS specifications.	<ul style="list-style-type: none"> • This transponder interfaces with legacy network equipment through proprietary means. • Type 1 is a standards-compliant transponder (either manufactured to the standard or upgraded) that connects to legacy network equipment via a proprietary interface.
<i>Type 2</i>	Refers to a stand-alone, HMS-compliant transponder.	<ul style="list-style-type: none"> • This transponder interfaces with network equipment designed to support the electrical and physical specifications defined in the HMS standards. • It can be factory or field-installed. • Its RF connection is independent of the monitored NE.
<i>Type 3</i>	Refers to a stand-alone or embedded, HMS-compliant transponder.	<ul style="list-style-type: none"> • This transponder interfaces with network equipment designed to support the electrical specifications defined in the HMS standards. • It may or may not support the physical specifications defined in the HMS standards. • It can be factory-installed. It may or may not be field-installed. • Its RF connection is through the monitored NE.

1.3 HMS Reference Architecture Forward and Return Channel Specifications

The reference architecture for the HMS suite of specifications is illustrated in **Figure 1**.

Figure 1: HMS Reference Architecture Diagram

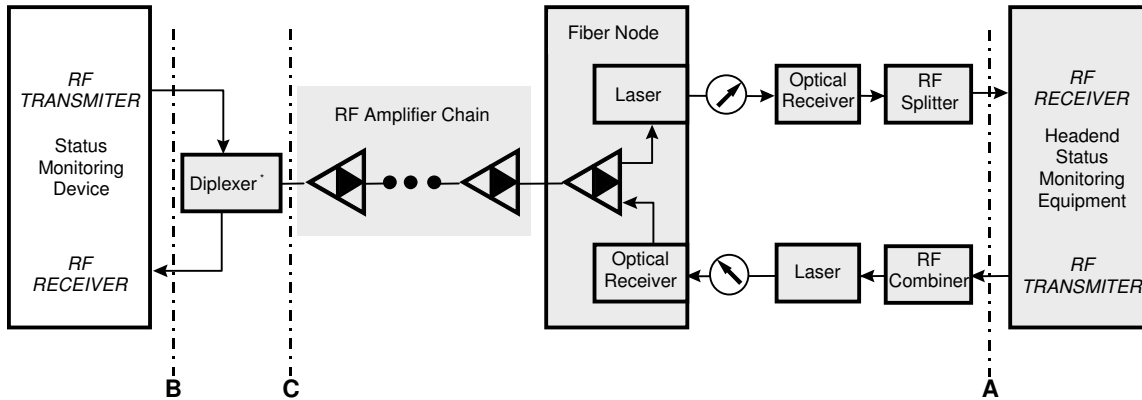

** The diplexer filter may be included as part of the network element to which the transponder interfaces, or it may be added separately by the network operator.*

All quantities relating to forward channel transmission or reverse channel reception are measured at point A in **Figure 1**. All quantities relating to forward channel reception or reverse channel transmission are measured at point B for two-port devices and point C for single-port devices as shown in **Figure 1**.

1.4 HMS Specification Documents

A list of documents in the HMS specifications family is provided in **Table 2**.

Table 2: HMS Document Family

HMS Notation	Title
SCTE HMS PHY	HMS Outside Plant Status Monitoring – Physical (PHY) Layer Specification
SCTE HMS MAC	HMS Outside Plant Status Monitoring – Media Access Control (MAC) Layer Specification
SCTE HMS PSTIB	HMS Outside Plant Status Monitoring – Power Supply to Transponder Interface Bus (PSTIB) Specification
SCTE HMS ALARMS MIB	HMS Alarms Management Information Base
SCTE HMS COMMON MIB	HMS Common Management Information Base
SCTE HMS FIBERNODE MIB	HMS Fiber Node Management Information Base
SCTE HMS PROPERTY MIB	HMS Alarm Property Management Information Base
SCTE HMS PS MIB	HMS Power Supply Management Information Base
SCTE ROOT MIB	SCTE Root Management Information Base
SCTE HMS GEN MIB	HMS Power Supply Generator Management Information Base
SCTE HMS TIB MIB	HMS Transponder Interface Bus Management Information Base
SCTE HMS DOWNLOAD MIB	HMS Transponder Firmware Download Management Information Base
SCTE HMS TREE MIB	HMS Root Object Identifiers Management Information Base

2 Power Supply to Transponder Interface Bus Specification Overview

Version 1.0 of the HMS PSTIB specification defines a status monitoring topology intended to replace existing analog, discrete status monitoring interfaces used today for monitoring power supplies and other power-related equipment deployed in HFC networks. In this topology, the transponder is simplified by moving all measurements and sensors to the monitored equipment; i.e., power supply or other power equipment. The transponder interfaces to the monitored equipment through a single multi-conductor cable. Transponder power is also provided through this interface. The power supply or other monitored power equipment assumes responsibility for measuring battery parameters, voltages, and other data associated with the equipment installation. Status and commands are passed between transponder and monitored equipment via a serial data interface bus.

The data protocol and command set are simple enough to be implemented in a simple micro-controller. The communication protocol is open and expandable such that as new requirements are defined they can be easily added to new revisions of this specification.

2.1 Interface Compliance

Transponder and power supply vendors meeting the mechanical and electrical interface requirements at the PHY layer and the packet and protocol message formats at the DLL layer that are defined within this specification are said to be interface compliant. A `Get_Configuration` command (see Section 4.4.3) enables the transponder to determine compliance with a particular revision of this specification for power supplies or other power equipment. Support for this capability is critical as the PSTIB specification is updated over time and power supply equipment supporting different revisions of this specification co-exists within the same network.

2.2 Implementation Compliance

Not all vendors will support the complete data set defined throughout this specification. The `Get_Configuration` response (see Section 4.4.3) provides the transponder or EMS with the specific status data that is and is not supported for each installation.

2.3 Revision Control

The command and response data in this specification is synchronized with associated HMS SNMP MIBs (see **Table 2**) that are used to represent this data in management systems. To maintain synchronization, a revision control mechanism must exist. Therefore, any time this specification is revised such that new data items are added to any command or response, those data items shall be appended to the END of an existing command or response definition. New command and response sequences may also be created as needed. No revision shall change the location, definition or function of a previously defined datum.

3 Power Supply to Transponder Interface Bus - Physical Layer Specification

3.1 Interface Requirements

3.1.1 Connector Type

The physical connector to support serial communications over the PSTIB between HMS-compliant transponders and managed OSP power supply hardware shall implement the following:

1. RJ-45, eight-wire conductor.
2. Appropriate metallic plating for outdoor usage.
3. Operating temperature: -40 degrees Celsius to +70 degrees Celsius.
4. Dual connectors wired in parallel shall be included on the monitored equipment to support daisy-chaining multiple monitored devices from a single HMS-compliant transponder.

3.1.2 Communications Interface

The communications interface shall support the RS-485 standard as defined in TIA/EIA-485-A (ANSI/TIA/EIA-485-A-98), “Electrical Characteristics of Generators and Receivers for Use in Balanced Digital Multipoint Systems”.

3.1.3 Connector Signals

Connector pins shall support signaling as described in **Table 3**.

Table 3: RJ-45 Connector Pin Assignment

Connector Pin Number	Signal
1, 8	Ground
2, 7	+24 VDC \pm 15% at 200 mA
3, 6	RS-485 (+)
4, 5	RS-485 (-)

3.1.4 Transponder Power

Powering of transponders from PSTIB interface compliant power supplies shall support the following attributes:

1. The transponder is powered only from the power supply. The transponder shall not connect directly to the system batteries.
2. The power supply shall implement appropriate isolation and system grounding such that the communication interface and transponder power remains functional under the operating conditions defined herein.
3. The transponder shall be bonded to chassis ground directly and/or through the system coaxial cable sheath.
4. Optionally, transponder power may be bonded to chassis ground at the power supply interface. The power supply vendor shall determine this.
5. The power supply shall implement appropriate over-current and short-circuit protection of transponder power such that the communication interface and transponder power remain functional under the operating conditions defined herein.
6. Up to eight (8) power supplies may be connected in parallel using the RS-485 interface.

3.1.5 Line Balance

3.1.5.1 Monitored Equipment

Line balance for monitored equipment shall be implemented as follows:

1. RS-485 (+) to +5 VDC through a resistor (jumper/switch removable).
2. RS-485 (-) to Ground through a resistor (jumper/switch removable).
3. RS-485 (+) tied to RS-485 (-) through a resistor (jumper/switch removable).
4. Monitored equipment shall include jumpers to select or bypass resistors to an open state. Jumper or switch-selectable terminating resistors enable on-site configuration of individual installations. Transponders shall include line balance resistors only. Refer to **Figure 2**.

3.1.5.2 Transponder

Line balance for transponders shall be implemented as follows:

1. RS-485 (+) tied to RS-485 (-) through a required resistor.

Note

Values for each resistor and the decision to include or exclude specific bias resistors as a default shall be determined by individual vendors.

3.1.6 Cable Length

TIA/EIA-485-A specifies a maximum cable length of 4,000 feet (@ 100 kbps) per properly terminated wire segment.

3.1.7 Data Encoding

Non-return to zero (NRZ), asynchronous, 1 start bit, 8 data bits (ordering: bit 1,2 ...8), 1 stop bit. All integers are transmitted most significant byte first. Any exceptions to this rule will be specifically noted in this document as necessary.

3.1.8 Bit Rate

Bit rate supported shall be 9,600 baud.

3.1.9 Duplex

This interface shall support half duplex operation. Multi-drop characteristics of RS-485 enable up to 32 drops per segment without signal repeaters.

3.1.10 Method of Communications

All communication is transponder-initiated. One monitored device response per query.

3.1.11 Indicators

An LED or other visual device installed at the monitored equipment shall indicate communications has been established with a transponder over the PSTIB interface.

3.2 Interface Diagram

The diagram in **Figure 2** illustrates a sample RS-485 interface implementation to support PSTIB communications. This diagram should *not* be interpreted as a design requirement. It is only included to help clarify line bias and termination resistor placement. **Table 4** describes the various signals that have been referenced in this diagram.

Figure 2: Sample PSTIB RS-485 Interface

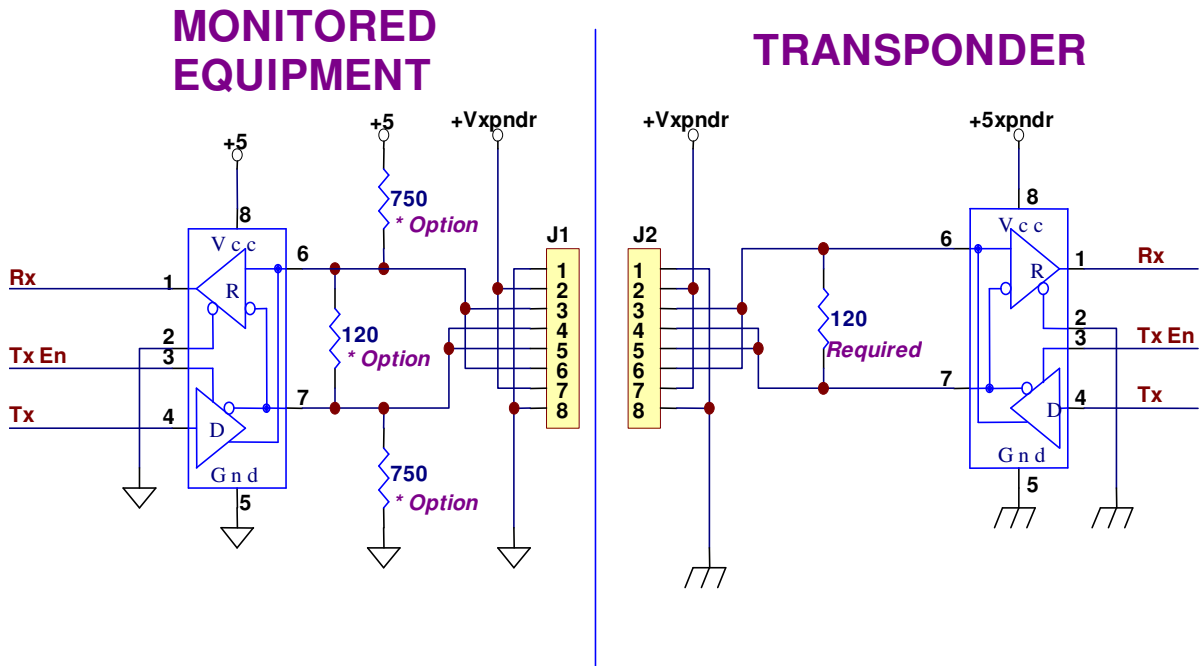

Table 4: Sample PSTIB RS-485 Interface – Reference Signals

Signal Notation (Figure 2)	Description
+5	Monitored equipment voltage
+Vxpndr	Voltage supplied from the monitored equipment to the transponder as defined per this specification
+5xpndr	Transponder operating voltage derived at the transponder from +Vxpndr
*Option	Indicates resistors that can be included or removed from circuit via user configurable jumper or switch
Required	Indicates resistor is required per this specification
J1, J2	The RJ-45 connectors used to interface transponders to monitored equipment. Pin numbers show currently defined interface signals per this specification
Rx, Tx, Tx En	Transmit, Receive and Transmit Enable. Illustrates possible connections to an RS-485 interface IC.
GROUND	The transponder shall be chassis grounded. The monitored equipment may be tied to chassis ground directly; i.e.: at the monitored equipment status interface, or through the interface ground (J1 pins 1,8). This shall be at the discretion of the monitored equipment vendor. The monitored equipment and status interface shall function correctly with whatever grounding method is selected.

4 Power Supply to Transponder Interface Bus – Data Link Layer Specification

4.1 DLL Packet Structure

DLL packets consist of the following: start field, destination address field, source address field, identification field, a variable-length datagram field, end field and two-byte checksum field. DLL packet structure is illustrated in **Figure 3**.

Figure 3: DLL Packet Structure

Start						End
Start	Destination Address	Source Address	Identification	Datagram	End	Checksum

All DLL packets must have the general format as described in **Table 5**.

Table 5: Generic DLL Packet Structure

Field Name	Length (bits)	Section
Start	16	4.1.1
Destination Address	8	4.1.2
Source Address	8	4.1.3
Identification	8	4.1.4
Datagram	32 to N	4.1.5
End	16	4.1.6
Checksum	16	4.1.7

4.1.1 Start

The Start field consists of two octets (bytes). This is the start sequence of all communication packets. This field shall consist of DLE (0x10) followed by STX (0x02).

4.1.2 Destination Address

The Destination Address field consists of a single octet and it uniquely identifies the device receiving the packet. Its value is between 0x00 and 0xFF (0-255 decimal). **Table 6** includes the ranges of addresses that are currently defined as part of this specification.

Table 6: Reserved Destination Address Ranges

Range (Decimal)	Range (Hexadecimal)	Reserved For
0	0x00	Transponders
1 – 8	0x01 – 0x08	Power Supplies and Generators
9 – 15	0x09 – 0x0F	Reserved for HMS use *
16 – 127	0x10 – 0x7F	Reserved for vendor specific use **
128 – 255	0x80 – 0xFF	Reserved for HMS use

Notes:

* It is recommended that 0x10 not be used as a device address to avoid additional DLE sequences (defined later in Section 4.2).

** Destination address ranges 16 – 127 (0x10 – 0x7F) are reserved for non-standard vendor use of the PSTIB. Vendor specific use of the PSTIB shall still meet all physical, DLL packet structure, timing, message synchronization and interaction requirements defined in this specification. Non-standard vendor specific use of the PSTIB shall not interfere with or interrupt standard communications between devices on the PSTIB.

Because vendor specific use of the PSTIB is not controlled by the standard, it is strongly recommended company/product datagram identifiers be employed to avoid interoperability issues between possible differing applications on the same destination addresses.

4.1.3 Source Address

The Source Address field consists of a single octet and it uniquely identifies the device sending the packet. Its format is the same as that of the Destination Address field.

4.1.4 Identification

The Identification field consists of a single octet. It is used to help identify the packet and match send-receive packet sequences. The contents of this field are defined by the device initiating communications; i.e., as currently defined, this will always be the transponder. The receiving device will repeat the Identification in the corresponding field of its response packet.

4.1.5 Datagram

The Datagram field consists of a minimum of four octets. It contains the commands, command responses and data delivered to/from the higher layer protocols. Various datagram types and their structure are defined later in Section 4.4.

4.1.6 End

The End field consists of two octets. This is the end sequence of all communication packets. This field shall consist of DLE (0x10) followed by ETX (0x03).

4.1.7 Checksum

The Checksum field consists of two octets. This is the 16-bit (modulo 0x10000) sum of all bytes in the packet *excluding* the Start, End, and Checksum fields and any stuffed DLEs.

4.2 DLE Sequence

Data Link Escape (DLE) sequence stuffing assures that both START (DLE, STX) and END (DLE, ETX) sequences will never be duplicated within the body of a packet. This technique is used to facilitate identifying the start and end of variable-length packets. Within the packet, if an octet is encountered having the value DLE; i.e., hexadecimal 0x10 or decimal 16, a second DLE is inserted into the data stream when the packet is transmitted. The following example illustrates this technique (data represented in hexadecimal format):

Original packet:	10 02 30 20 63 10 03 00 10 03 00 C6
DLE stuffed:	10 02 30 20 63 10 10 03 00 10 03 00 C6

Note

The above example illustrates only the DLE stuffing technique. Specific Command and Response information is not intended to represent actual data.

Notice the 6th and 7th octets in the original packet in the above example. These could mistakenly be interpreted as the end-of-packet sequence. The DLE-stuffed packet includes an additional DLE inserted in the sequence. The receiving device will detect the DLE DLE combination, discard the inserted DLE and ignore the DLE ETX code embedded within the packet.

The following rules shall apply to DLE stuffing:

1. DLE stuffing is applied to the entire packet including the checksum. Therefore, an additional DLE character will be added for each checksum byte sent as 0x10 (DLE).
2. The start packet sequence (DLE, STX) and end packet sequence (DLE, ETX) are *not* DLE stuffed.
3. The value in any DLL datagram “Size of Data” field (see Section 4.4.1.2) does *not* include any stuffed DLE characters.
4. Stuffed DLE characters are *not* included in packet checksum calculations.

4.3 Interface Timing

4.3.1 Message Synchronization and Interaction

Transponders and monitored equipment must conform to the following:

1. Transponders initiate all communications. Monitored equipment; e.g.: power supplies, shall only respond to packets addressed to them.
2. Transponders powered directly via the RJ-45 physical connector from a PSTIB interface compliant power supply shall wait at least 15 seconds after power up and initialization before attempting to discover what power supplies they are connected to over the same PSTIB interface. A power supply shall be fully initialized and capable of responding to any data message as defined in this specification within 15 seconds after it has enabled power over the PSTIB interface to the transponder. The power supply shall not respond, nor respond with incorrect data, if it is interrogated before this time elapses.
3. Transponders shall assign each data message a unique identification (refer to Section 4.1.4). The responding device shall repeat this identifier in the identification field of the response packet. The transponder shall verify the message identifier ensuring command/response synchronization.
4. Transponders should include a mechanism to re-request or retry communications when either a corrupt response or no response is received from the monitored equipment. Since communication errors will occur in any system, transponders shall retry communications a minimum of three (3) times before reporting loss of communications with the monitored equipment to the EMS. If loss of communications occurs, the transponder shall attempt to re-establish communications with the monitored equipment at regular intervals. All communications shall conform to the timing requirements defined in this document. See Section 4.3.2.
5. During operation, transponders shall periodically attempt discovery of new devices attached to the PSTIB. An auto-discovery attempt for all HMS device addresses defined in this specification (destination addresses: 1-8) shall effectively occur every 5 minutes or less. In this process of auto-discovery, transponders shall query for new or changed configuration of devices on the PSTIB.

4.3.2 Transmission Timing Requirements

Figure 4 illustrates the data and timing diagram for transmissions over the PSTIB. **Table 7** describes all relevant timing parameters and allowed minimum and maximum values.

Figure 4: PSTIB Data and Timing Diagram

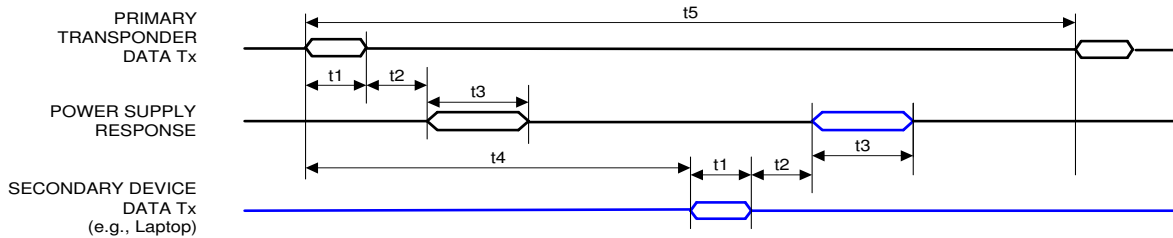

Table 7: PSTIB Timing Specifications

Identifier	Characteristic	Minimum Value	Maximum Value
t1	PRIMARY or SECONDARY device packet duration	-	30 ms
t2	Delay – PRIMARY or SECONDARY device message complete to power supply start response	1 ms	30 ms
t3	Power supply packet duration (chatter detection)	-	300 ms
t4	PRIMARY device packet start to SECONDARY device packet start	390 ms	510 ms
t5	PRIMARY device poll cycle period	900 ms	3 s

The diagram in **Figure 4** and **Table 7** make provision for more than one device initiating communications over the PSTIB. If a device initiating communications is a transponder, i.e.: a device with address 0x00, it is referred to as a PRIMARY device. If the device initiating communications is one with a non-zero address, i.e.: a laptop PC or another transponder with non-zero address, it is referred to as a SECONDARY device.

4.3.2.1 Requirements for PRIMARY and SECONDARY Devices

It may be desirable for on-site technicians to access power supply and generator system status using a laptop PC. This section defines the timing requirements for a laptop-based PC application program to send and receive status to and from the monitored equipment via the RS-485 interface without disrupting communications to or from the transponder. The following rules govern this mode of operation:

1. Transponders and monitored equipment shall anticipate that there may be a SECONDARY device, e.g.: a laptop PC, connected to the RS-485 bus.

2. The PRIMARY device, also called the transponder, shall be set to address zero. The SECONDARY device shall be set to any unused address.
3. In order to establish timing synchronization with the SECONDARY device, the transponder (with address 0x00) shall regularly transmit packets at a period herein defined by the timing requirements for the PRIMARY transponder.
4. The SECONDARY device shall determine if there is a zero-addressed PRIMARY device on the bus. It will do this by listening on the bus for a zero-addressed transponder.
5. If the SECONDARY device listens on the bus for a time equal to the maximum value of a PRIMARY device poll cycle period, i.e.: 3 seconds, and does not hear a zero-addressed transponder, it shall proceed to operate as if it is the PRIMARY transponder.
6. If a SECONDARY device is acting as PRIMARY, and if 60 or more seconds have passed since the SECONDARY device has listened for a zero-addressed transponder, the SECONDARY device shall not transmit until it has again determined if there is a zero-addressed transponder on the bus.
7. A PRIMARY transponder shall be able to tolerate continuous bus collisions for up to 60 seconds without crashing and without deviating from any other requirements assigned to a PRIMARY transponder, i.e.: it needs to continue transmitting at the defined period even though it may not be receiving any responses.
8. If a SECONDARY device; i.e.: a device with non-zero address, is acting as PRIMARY and determines that a zero-addressed transponder has been placed on the bus, the non-zero addressed device shall cease acting like a PRIMARY transponder and immediately start acting like a SECONDARY device.
9. When a PRIMARY transponder is on the bus, a SECONDARY device shall start any transmission no less than “t4 minimum” after it has seen the PRIMARY transponder start a transmission.
10. When a PRIMARY transponder is on the bus, a SECONDARY device shall start its transmission no more than “t4 maximum” after it has seen the PRIMARY transponder start a transmission.
11. Transponders which are permanently installed in a system shall be configured with address 0x00 and operate as a PRIMARY transponder.
12. For all responses, PRIMARY and SECONDARY devices shall confirm that the destination address is their own address, and process only those packets addressed to them; i.e.: devices must *not* assume that all traffic on the bus is either from or to them.
13. Monitored equipment shall be able to service requests from multiple devices. The monitored equipment can be assured by these rules that messages will never be

interleaved; i.e.: while responding to one device, they will never receive a request from a second device.

4.4 DLL Datagrams

4.4.1 Structure

The Datagram field is defined as part of the DLL packet structure (see **Figure 3**). Datagrams contain commands, command responses and associated data. DLL datagram structure is illustrated in **Figure 5**.

Figure 5: DLL Datagram Structure

COMMAND/ RESPONSE	Size of Data	Variable Binding
----------------------	--------------	------------------

All DLL datagrams must have the general format as described in **Table 8**.

Table 8: Generic DLL Datagram Structure

Field Name	Length (bits)	Section
COMMAND/RESPONSE	16	4.4.1.1
Size of Data	16	4.4.1.2
Variable Binding	0 to N	4.4.1.3

4.4.1.1 Command/Response

The Command/Response field consists of two octets (bytes). This field defines what action is to be performed. The Command/Response field is always present. Valid commands and responses are defined later in Section 4.4.3. This two-octet field is transmitted most significant byte first.

4.4.1.2 Size of Data

The Size of Data field consists of two octets. This value defines the size (in bytes) of the Variable Binding field. This Size of Data field is always present. If no data is associated with the command, the size will be 0x0000. This two-octet field is transmitted most significant byte first.

4.4.1.3 Variable Binding

This variable field contains data. The data length and content are specific to a particular command/response. This field is not always present. If no data are present, the Size of Data field is set to 0x0000.

4.4.2 Resolution Versus Accuracy

The Variable Binding field in a DLL datagram contains digital representations of analog values. The resolution of each analog value is listed in the tables describing associated variable bindings for each DLL datagram type in Section 4.4.3. Resolution does not imply accuracy. Vendors should disclose accuracy of status data for equipment in compliance with this specification. Any scaled analog representation from a Get_Power_Supply_Data response (see Section 4.4.3.4) that reaches the minimum or maximum range defined for that value, i.e.: 0 or 255, shall report the maximum (or minimum) value and *not* wrap around.

4.4.3 DLL Datagram Types

Valid Datagram types defined in this specification are listed in **Table 9**.

Table 9: DLL Datagrams

Datagram Name	Encoding*	Size of Data (Bytes)	Section
Get_Configuration (Command)	0x3030	0	4.4.3.1
Get_Configuration (Response)	0x3130	Device type dependent	4.4.3.2
Get_Power_Supply_Data (Command)	0x3031	0	4.4.3.3
Get_Power_Supply_Data (Response)	0x3131	33	4.4.3.4
Power_Supply_Control (Command)	0x3232	1	4.4.3.5
Get_Generator_Data (Command)	0x3033	0	4.4.3.6
Get_Generator_Data (Response)	0x3133	10	4.4.3.7
Generator_Control (Command)	0x3234	1	4.4.3.8
Invalid_Request (Response)	¹ 0x34nn	1	4.4.3.9
Request_Processed (Response)	² 0x35nn	0	4.4.3.10
<i>Reserved for vendor specific use**</i>	0xC000 – 0xFFFF	Defined by vendor	N/A

¹nn is the second byte of the command that was not recognized.

²nn is the second byte of the command being processed.

Notes:

* All DLL Datagram encoding values not specifically defined in Table 9 are reserved for future HMS use.

** Datagram encoding range from 0xC000 through 0xFFFF is reserved for non-standard, vendor specific use of the PSTIB. Vendor specific use of the PSTIB shall still meet all physical, DLL packet structure, timing, message synchronization and interaction requirements defined in this specification.

Non-standard, vendor specific use of the PSTIB shall not interfere with or interrupt standard communications between devices on the PSTIB.

Because vendor specific use of the PSTIB is not controlled by the standard, it is strongly recommended company/product datagram identifiers such as: Get_Configuration (Response) “ID” be employed to avoid interoperability issues between possible differing vendor applications using the same encoding value.

4.4.3.1 Command: Get_Configuration

Table 10 provides a description for this datagram.

Table 10: Command: Get_Configuration Datagram

Description	Encoding	Size of Data (Bytes)	Variable Binding
This command from the transponder to the monitored equipment requests the configuration status of the monitored device	0x3030	0	[NULL]

4.4.3.2 Response: Get_Configuration

Table 11 provides a description for this datagram.

Table 11: Response: Get_Configuration Datagram

Description	Encoding	Size of Data (Bytes)	Variable Binding
Response from the monitored device to the transponder to a “Get_Configuration” command	0x3130	¹ Device type dependent	² Contains table of configuration data. See Table 12 , Table 13 and Table 14 .

¹Fields in a Get_Configuration response are not allowed to assume the value “255” which is reserved as an extension flag for the unlikely event that any of the fields need to be represented as values >255. This condition can be addressed in later revisions as required but the value 255 is reserved at this time to assure later backward compatibility.

²Fields containing ASCII text data are NULL terminated; i.e., any unused locations AFTER the test message SHALL be filled with NULL characters (0x00). NULL characters are used to indicate the end of a text message and SHALL NOT be represented with any printed character(s) on the EMS display terminal.

Table 12: Response: Get_Configuration Datagram¹ Variable Binding (General)

Field #	Field Name	Range ²	Description
1	Protocol Version	1-254	Version of the SCTE HMS protocol implemented in the monitored equipment. The value in this field indicates the HMS PSTIB interface version that has been implemented in the responding device, multiplied by 10 (decimal) ³ . Example: A power supply implementing all commands and responses defined in HMS PSTIB Rev 1.1 would return a value of "11" (decimal) in this field.
2	Device Type	1-254	A code identifying the general class of equipment being monitored. The intent of this field is to provide a one-to-one correspondence between a monitored device and a MIB file used by the EMS. Devices are defined as: <ol style="list-style-type: none"> 1. Power supply – corresponds to SCTE HMS PS MIB document 2. Generator – corresponds to SCTE HMS GEN MIB document 3. Fiber Node – corresponds to SCTE HMS FIBERNODE MIB document
3	Software Version	8 Octets	The content of this field is vendor-specific. The intent is to provide a text representation of the power supply or generator system software version. Any printable ASCII characters can be included in this field. NULL (0x00) characters are non-printable and are used to fill any unused locations in the 8-octet field following the text data
4	ID	32 Octets	The content of this field is vendor-specific. The intent is to provide manufacturer and/or product specific ASCII text information that will propagate to the management console verbatim. The following special characters are defined in association with this field: <p>“\n” - used to cause a new line on the console display. Example: “ALPHAXM2 9015” would appear at the monitoring station as:</p> <p style="margin-left: 40px;">ALPHA XM2 9015</p>

¹Field entries 1 through 4 defined in this table are common to all monitored devices. The balance of field entries for the Response: Get_Configuration datagram are “Device Type” specific; i.e.: power supplies respond differently from field power generators. See Section 4.4.3.2.1 and Section 4.4.3.2.2 for additional details.

²Each field is one octet (8 bits) in length unless the size in octets is otherwise specified.

³The “Protocol Version” field definition changed in version 1.1 of this specification. In version 1.0, the specification stated that the devices were to return the value 1 to indicate that they conform with version 1.0 of the specification. However, in anticipation of the change made in version 1.1 of this specification some vendors return the value 10 in this field as an indication that the device is compliant with version 1.0 of this specification. So transponders need to recognize that a response of either 1 or 10 means compliance with version 1.0 of this specification.

4.4.3.2.1 Power Supplies

Table 13 in this section defines the balance of field entries expected from power supplies in the variable binding for the Response: Get_Configuration datagram.

Table 13: Response: Get_Configuration Datagram^{1,2} Variable Binding (Power Supply)

Field #	Field Name	Range ³	Description
5	Batteries	0-8	<p>Number of batteries per string. Example: A 36V system will return “3” (0x03) in this field. A system may return “0” (0x00) to represent no batteries connected. This field enables the transponder and/or EMS to determine what quantity of “V(batt)” battery voltage measurements should be used (listed in the Get_Power_Supply_Data response).</p> <p><i>Note: The number of batteries reported shall not exceed 8 for a single string and 4 for a dual string. Systems reporting more than 4 batteries are limited to 1 battery string.</i></p> <p><i>Note: The transponder and/or EMS will interpret a “0” (0x00) returned from either Get_Configuration – “Batteries” or “Battery Strings” as no batteries connected.</i></p>
6	Battery Strings	0-2	<p>Number of battery strings. This field enables the transponder and/or EMS to determine the number of battery strings connected to a power supply and how “V(batt)” data is handled from a Get_Power_Supply_Data request. Example: A Battery Strings value of “0” indicates that all V(batt) data should be ignored (no batteries are connected). A Battery Strings value of “1” indicates that there is a single system battery string of up to 8 batteries (quantity defined by Get_Configuration – Batteries). A Battery Strings value of “2” indicates two system battery strings of up to 4 batteries each.</p> <p><i>Note: The transponder and/or EMS will interpret a “0” (0x00) returned from either Get_Configuration – “Battery Strings” or “Batteries” as no batteries connected.</i></p>
7	Temperature Sensors	0-2	<p>Number of battery temperature sensors.</p> <p><i>Note: The location of each temperature sensor is application-specific.</i></p>
8	Outputs	1-5	<p>Number of power supply outputs. This field enables the transponder and/or EMS to determine how many of the “I(out) 1-5” values represented in fields 2, 3, 4, 5 and 6 of the Get_Power_Supply_Data response datagram should be used. If only one output is active, I(out) 1 will be used.</p>
9	Battery Current	1-4	<p>Defines if battery current is measured in this installation. Values are enumerated as follows:</p> <p>1 = No battery current measurements. Discard associated values in fields 16, 17, 18 and 19 of the Get_Power_Supply_Data response datagram.</p> <p>2 = Battery string “A” current only is measured. This setting also applies to a single current sensor setup to measure the sum of both battery strings “A+B”. Indicates that the values in fields 16 and 18 of the Get_Power_Supply_Data response datagram are valid, and that fields 17 and 19 should be discarded.</p> <p>3 = Battery string “B” current only is measured. Indicates that the values in fields 17 and 19 of the Get_Power_Supply_Data response datagram are valid, and that fields 16 and 18 should be discarded.</p> <p>4 = Battery strings “A” and “B” are measured with separate sensors. Indicates that the values in fields 16, 17, 18 and 19 of the Get_Power_Supply_Data response datagram are all valid.</p>

Field #	Field Name	Range ³	Description
10	Float Current	1-4	Same format as "Battery Current". Values are enumerated as follows: 1 = No float current measurements. Discard associated values in fields 26 and 27 of the Get_Power_Supply_Data response datagram. 2 = Battery string "A" float current only is measured. This setting also applies to a single current sensor setup to measure the sum of both battery strings "A+B". Indicates that the value in field 26 of the Get_Power_Supply_Data response datagram is valid, and that field 27 should be discarded. 3 = Battery string "B" float current only is measured. Indicates that the value in field 27 of the Get_Power_Supply_Data response datagram is valid, and that field 26 should be discarded. 4 = Battery strings "A" and "B" are measured with separate sensors. Indicates that the values in fields 26 and 27 of the Get_Power_Supply_Data response datagram are valid.
11	Output Voltage	1,2	Defines if power supply supports monitoring of output voltage 1 = No support. Discard associated value in field 1 of the Get_Power_Supply_Data response datagram. 2 = Field is supported in this installation. Indicates that the value in field 1 of the Get_Power_Supply_Data response datagram is valid.
12	Input Voltage	1,2,3	Defines if power supply supports monitoring of input or line voltage 1 = No support. Discard associated data in field 7 of the Get_Power_Supply_Data response datagram. 2 = Field is supported – binary representation. Indicates that field 7 of the Get_Power_Supply_Data response datagram contains valid data. 3 = Field is supported – analog representation. Indicates that field 7 of the Get_Power_Supply_Data response datagram contains valid data.
13	Power Supply Test	1,2	Defines if power supply supports the remote test feature: 1 = Function not supported. 2 = Function is supported.
14	Major Alarm	1,2	Defines if the power supply supports the major alarm indicator: 1 = No support. Discard associated value in field 23 of the Get_Power_Supply_Data response datagram. 2 = Field is supported in this installation. Indicates that field 23 of the Get_Power_Supply_Data response datagram contains valid data.
15	Minor Alarm	1,2	Defines if the power supply supports the minor alarm indicator: 1 = No support. Discard associated value in field 24 of the Get_Power_Supply_Data response datagram. 2 = Field is supported in this installation. Indicates that field 24 of the Get_Power_Supply_Data response datagram contains valid data.
16	Tamper	1,2	Defines if the enclosure door switch is installed in this location: 1 = No support. Discard associated value in field 25 of the Get_Power_Supply_Data response datagram. 2 = Field is supported in this installation. Indicates that field 25 of the Get_Power_Supply_Data response datagram contains valid data.
17	Battery Monitoring	1,2,3	Defines support level for battery voltage monitoring 1 = No battery voltage is monitored. Discard associated values in fields 8, 9, 10, 11, 12, 13, 14, 15 and 28 of the Get_Power_Supply_Data response datagram. 2 = ONLY full string battery voltage is reported. Indicates that the value in field 28 of the Get_Power_Supply_Data response datagram is valid, and that fields 8, 9, 10, 11, 12, 13, 14 and 15 should be discarded. 3 = Individual battery voltages are reported. Full string voltage is also reported. Indicates that fields 8, 9, 10, 11, 12, 13, 14, 15 and 28 of the Get_Power_Supply_Data response datagram are all valid.

Field #	Field Name	Range ³	Description
18	Output Power	1,2	Defines if the output power is reported: 1 = No support. Discard associated value in field 30 of the Get_Power_Supply_Data response datagram. 2 = Field is supported in this installation. Indicates that the value in field 30 of the Get_Power_Supply_Data response datagram is valid.
19	Output Frequency	1,2	Defines if the output frequency is reported: 1 = No support. Discard associated value in field 31 of the Get_Power_Supply_Data response datagram. 2 = Field is supported in this installation. Indicates that the value in field 31 of the Get_Power_Supply_Data response datagram is valid.
20	Input Current	1,2	Defines if the input current is reported: 1 = No support. Discard associated value in field 32 of the Get_Power_Supply_Data response datagram. 2 = Field is supported in this installation. Indicates that the value in field 32 of the Get_Power_Supply_Data response datagram is valid.
21	Input Power	1,2	Defines if the input power is reported: 1 = No support. Discard associated value in field 33 of the Get_Power_Supply_Data response datagram. 2 = Field is supported in this installation. Indicates that the value in field 33 of the Get_Power_Supply_Data response datagram is valid.
22	Frequency	1,2	Defines input frequency of power supply: 1 = 50Hz 2 = 60 Hz

¹Field entries 1 through 4 are defined in **Table 12** and are common to all monitored devices.

²Power supply specific fields have limited ranges due to physical limitations. Extensions to this range or additional fields can be accommodated in future versions of this protocol if required.

³Each field is one octet (8 bits) in length.

4.4.3.2.2 Generators

Table 14 in this section defines the balance of field entries expected from field power generators in the variable binding for the Response: Get_Configuration datagram.

Table 14: Response: Get_Configuration Datagram¹ Variable Binding (Generator)

Field #	Field Name	Range ²	Description
5	Gas Hazard	1,2	Defines if gas hazard sensor is installed 1 = Not installed. Discard associated value in field 2 of the Get_Generator_Data response datagram. 2 = Installed. Indicates that field 2 of the Get_Generator_Data response datagram contains valid data.
6	Water Intrusion	1,2	Defines if water intrusion sensor is installed 1 = Not installed. Discard associated value in field 3 of the Get_Generator_Data response datagram. 2 = Installed. Indicates that field 3 of the Get_Generator_Data response datagram contains valid data.
7	Pad Shear	1,2	Defines if pad shear sensor is installed 1 = Not installed. Discard associated value in field 4 of the Get_Generator_Data response datagram. 2 = Installed. Indicates that field 4 of the Get_Generator_Data response datagram contains valid data.
8	Enclosure Door	1,2	Defines if separate generator door sensor is installed 1 = Not installed. Discard associated value in field 5 of the Get_Generator_Data response datagram. 2 = Installed. Indicates that field 5 of the Get_Generator_Data response datagram contains valid data.
9	Charger	1,2	Defines if charger fail signal is supported 1 = Not supported. Discard associated value in field 6 of the Get_Generator_Data response datagram. 2 = Supported. Indicates that field 6 of the Get_Generator_Data response datagram contains valid data.
10	Fuel	1,2	Defines if low fuel detection is supported 1 = Not installed. Discard associated value in field 7 of the Get_Generator_Data response datagram. 2 = Installed. Indicates that field 7 of the Get_Generator_Data response datagram contains valid data.
11	V(Batt) Ignition	1,2	Defines if engine ignition battery voltage is monitored 1 = Not monitored. Discard associated value in field 8 of the Get_Generator_Data response datagram. 2 = Monitored. Indicates that field 8 of the Get_Generator_Data response datagram contains valid data.
12	T(Enclosure)	1,2	Defines if engine enclosure temperature is monitored 1 = Not monitored. Discard associated value in field 9 of the Get_Generator_Data response datagram. 2 = Monitored. Indicates that field 9 of the Get_Generator_Data response datagram contains valid data.

¹Field entries 1 through 4 are defined in **Table 12** and are common to all monitored devices.

²Each field is one octet (8 bits) in length.

4.4.3.3 Command: Get_Power_Supply_Data

Table 15 provides a description for this datagram.

Table 15: Command: Get_Power_Supply_Data Datagram

Description	Encoding	Size of Data (Bytes)	Variable Binding
This command from the transponder to the power supply requests discrete and analog data	0x3031	0	[NULL]

4.4.3.4 Response: Get_Power_Supply_Data

Table 16 provides a description for this datagram.

Table 16: Response: Get_Power_Supply_Data Datagram

Description	Encoding	Size of Data (Bytes)	Variable Binding
This response from the power supply to the transponder returns discrete and analog data	0x3131	34	Contains table of data. Each field is one octet in length. See Table 17.

Table 17: Response: Get_Power_Supply_Data Datagram Variable Binding

Field #	Field Name	Range ¹	Description
1	V(out)	1 VAC / bit	Scaled representation of power supply output voltage. This RMS value is common for all outputs in a multiple output system.
2	I(out)1	0.2 A / bit	Scaled representation of power supply RMS output current. This value is the total power supply output current if only one output is active. If multiple outputs are active, this value represents output #1 current.
3	I(out)2	0.2 A / bit	Same format as "Output Current Port 1"
4	I(out)3	0.2 A / bit	Same format as "Output Current Port 1"
5	I(out)4	0.2 A / bit	Same format as "Output Current Port 1"
6	I(out)5	0.2 A / bit	Same format as "Output Current Port 1"
7	V(line)	1.2 VAC / bit OR 1 = LOST 2 = OK	This field has two possible representations as defined in the "Get_Configuration" response. The two possible formats are: 1. Scaled representation of input "line" or "grid" voltage. This is an RMS value. 2. Digital value indicating that line voltage is present and within tolerance or not.

Field #	Field Name	Range ¹	Description
8	V(batt) 1A	0.1 VDC / bit	Scaled representation of individual battery voltages for string "A". <i>Note: V(batt) names in italics used only if batteries per string reported by Get_Configuration response is more than 4. A single string of 4 or less batteries shall report battery voltages in string "A" (V(batt) 1A – 4A). Dual strings shall report individual battery voltages per BATTERY NAMING CONVENTIONS in Section 4.4.3.4.1.</i>
9	V(batt) 2A	0.1 VDC / bit	Same as V(batt) 1A
10	V(batt) 3A	0.1 VDC / bit	Same as V(batt) 1A
11	V(batt) 4A	0.1 VDC / bit	Same as V(batt) 1A
12	V(batt) 1B OR V(batt) 5A	0.1 VDC / bit	Scaled representation of an individual battery voltage for string "B" or, in the case of greater than 4 batteries per string reported by Get_Configuration – "Batteries", a continuation of individual battery voltages from String "A" (per italic names).
13	V(batt) 2B OR V(batt) 6A	0.1 VDC / bit	Same as V(batt) 1B
14	V(batt) 3B OR V(batt) 7A	0.1 VDC / bit	Same as V(batt) 1B
15	V(batt) 4B OR V(batt) 8A	0.1 VDC / bit	Same as V(batt) 1B
16	I(batt discharge) A	1.0 A / bit	Scaled representation of battery string "A" discharge current. This is an RMS value. If multiple strings are installed but only one measurement sensor is used, this value represents the total battery discharge current. When batteries are being charged, this value will = 0.
17	I(batt discharge) B	1.0 A / bit	Same format as battery string "A" discharge current, but for secondary string "B" (if used).
18	I(batt charge) A	0.5 A / bit	Scaled representation of battery string "A" charge current. This is an RMS value. When batteries being discharged, this value will = 0.
19	I(batt charge) B	0.5 A / bit	Same format as battery string "A" charge current, but for secondary string "B" (if used).
20	Temp 1	0.5 C / bit (-40C offset)	Scaled representation of temperature sensor #1.
21	Temp 2	0.5 C / bit (-40C offset)	Scaled representation of temperature sensor #2.
22	Power Supply Status	1 = Normal Operation: Line Mode 2 = Standby Operation: Battery on Discharge 3 = Local Test In Progress 4 = Remote Test In Progress 5 = ALARM: Test Fail	Enumerated value indicates current status of Power Supply. Enumerations are defined as: 1 = <u>Normal Operation: Line Mode</u> – indicates supply is drawing power for output from utility mains. 2 = <u>Standby Operation: Battery on Discharge</u> – indicates supply is drawing power for output from battery, but not in test (loss of utility mains) 3 = <u>Local Test In Progress</u> – indicates power supply is currently performing an automated or locally initiated test cycle. 4 = <u>Remote Test In Progress</u> – indicates the power supply is currently performing a remotely initiated test cycle. 5 = <u>ALARM: Test Fail</u> – indicates the power supply failed its last test cycle
23	Major Alarm	1 = OK 2 = ALARM	Service has been dropped or a service interruption is imminent. Indicates that an immediate truck roll is appropriate. Specific alarms and alarm nomenclature varies between vendors. Vendors should disclose all conditions that contribute to this alarm in appropriate product literature.

Field #	Field Name	Range ¹	Description
24	Minor Alarm	1 = OK 2 = ALARM	A non-service affecting condition has occurred and should be monitored. Specific alarms and alarm nomenclature vary between vendors. Vendors should disclose all conditions that contribute to this alarm in appropriate product literature.
25	Door Status (Tamper)	1 = CLOSED 2 = OPEN	Indicates status of enclosure door. This notification is NOT included in the "Major" or "Minor" alarm fields. Individual users/installations must determine if a door open status represents an alarm and if so, of what severity.
26	I(float) A	0.01 A / bit	Scaled representation of battery "float" charge current for battery string "A". This field will be "0" under conditions other than during actual float charging. When this field is non-zero (reporting float current), other battery current values (charge and discharge) should be discarded. This field also represents the total float current for battery strings A+B when both strings are installed with only one sensor.
27	I(float) B	0.01 A / bit	Same format as I(float) A.
28	V(batt) Total	0.4 V / bit	Scaled representation of the full battery string voltage.
29	Local Control	1 = No 2 = Yes	Indicates that a technician is on-site and remote control operation has been disabled. Remote status is still available. Remote control operations are enabled when local control is no longer active.
30	W(out)	20 W / bit	Scaled representation of power supply output power.
31	F(out)	0.1 Hz / Bit (48.0 Hz Offset)	Scaled representation of the power supply output frequency.
32	I(in)	0.2 A / bit	Scaled representation of power supply RMS input current.
33	W(in)	20 W / bit	Scaled representation of power supply input power.

¹Each field is one octet (8 bits) in length.

4.4.3.4.1 Battery Naming Conventions

For consistency when referencing batteries in a Get_Power_Supply_Data response, the battery of lowest potential in a string shall be reported by the power supply as V(batt) 1 (string “A” or “B”). The battery of the highest potential in a string shall be reported as the highest appropriate value of V(batt).

Referencing **Figure 6**, the first battery in a single 36V string (measuring 12V nominal with reference to string minus) shall be “V(batt) 1A”. The next battery (measuring 24V nominal with reference to string minus) shall be “V(batt) 2A”. The final battery (36V with reference to string minus) shall be “V(batt) 3A”.

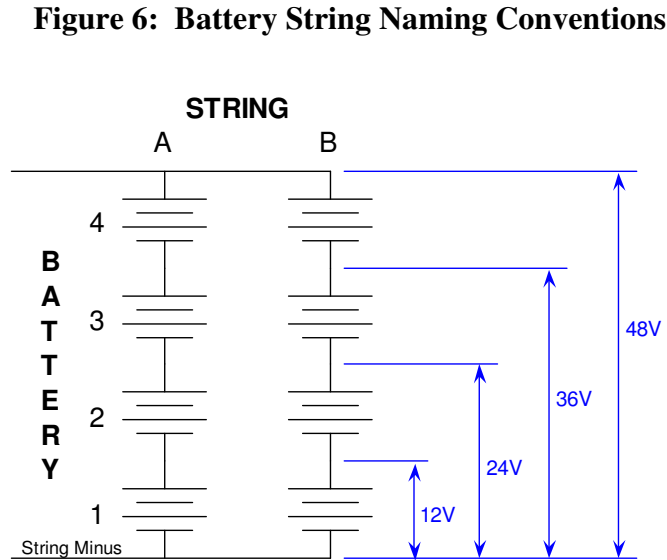

Figure 6: Battery String Naming Conventions

4.4.3.5 Command: Power_Supply_Control

Table 18 provides a description for this datagram.

Table 18: Command: Power_Supply_Control Datagram

Description	Encoding	Size of Data (Bytes)	Variable Binding
This command from the transponder to the monitored equipment requests an operation be initiated *	0x3232	1	1 = Discontinue power supply test ** 2 = Initiate power supply test

Notes:

* Power supply test commands are event driven: There is one command to initiate a test, one command to discontinue a test. Due to the nature of the equipment and communication, there may be a delay from the time a command is sent and a response from the power supply is noted. This time is defined by vendor and equipment.

** Depending on power supply vendor equipment, a “Discontinue Power Supply Test” command may also end local or automatically initiated power supply tests, as it would when remotely initiated. This functionality is defined by vendor.

4.4.3.6 Command: Get_Generator_Data

Table 19 provides a description for this datagram.

Table 19: Command: Get_Generator_Data Datagram

Description	Encoding	Size of Data (Bytes)	Variable Binding
This command from the transponder to the generator requests status and control data.	0x3033	0	[NULL]

4.4.3.7 Response: Get_Generator_Data

Table 20 provides a description for this datagram.

Table 20: Response: Get_Generator_Data Datagram

Description	Encoding	Size of Data (Bytes)	Variable Binding
This response from the generator to the transponder returns status and control data.	0x3133	10	Contains table of data. Each field is one octet in length. See Table 21.

Table 21: Response: Get_Generator_Data Datagram Variable Binding

Field #	Field Name	Range ¹	Description
1	Generator Status	1 = Off 2 = Running (test) 3 = Running 4 = Fail	Defines the current state of generator operation. "Fail" indicates a condition preventing the generator from functioning.
2	Gas Hazard	1 = OK 2 = ALARM	The concentration of hydrocarbon fuel in the generator enclosure has exceeded safe limits. Generator operation is suspended. The alarm is cleared when the sensor is reset via the "Reset Latched Generator Alarms" command.
3	Water Intrusion	1 = OK 2 = ALARM	Water level within the generator or fuel enclosure has exceeded safe limits for generator operation. Generator operation is suspended while this alarm is active. The alarm is reset when the water level returns to a safe level.
4	Pad Shear	1 = OK 2 = ALARM	Indicates that the generator or fuel enclosure has shifted from its mounting position. Generator operation is suspended. The alarm is reset when the unit is returned to its original position.
5	Enclosure Door	1 = Closed 2 = Open	Indicates current status of the generator and/or auxiliary fuel enclosure door.
6	Charger	1 = OK 2 = Fail	Indicates the ignition battery charger is operating.
7	Fuel	1 = OK 2 = Low	Indicates the engine fuel supply is insufficient for extended operation. The alarm is reset when fuel is replenished.
8	V(batt) Ignition	0.1 VDC / bit	Scaled representation of the generator ignition battery voltage.
9	T(Enclosure)	0.5 C / bit (-40C offset)	Temperature of generator enclosure.
10	Local Control	1 = No 2 = Yes	Indicates that a technician is on-site and remote control operation has been disabled. Remote status is still available. Remote control operations are enabled when local control is no longer active.

¹Each field is one octet (8 bits) in length.

4.4.3.8 Command: Generator_Control

Table 22 provides a description for this datagram.

Table 22: Command: Generator_Control Datagram

Description	Encoding	Size of Data (Bytes)	Variable Binding
This command from the transponder to the generator system requests an operation be initiated. *	0x3234	1	1 = Discontinue Generator Test ** (allow generator to stop normally) 2 = Initiate Generator Test 3 = Reset Latched Generator Alarms

Notes:

* Generator test commands are event driven: There is one command to initiate a test, one command to discontinue a test. Due to the nature of the equipment and communication, there may be a delay from the time a command sent and a response from the generator is noted. This time is defined by vendor and equipment.

** Depending on generator vendor equipment, a “Discontinue Generator Test” command may also end local or automatically initiated generator tests, as it would when remotely initiated. This functionality is defined by vendor.

4.4.3.9 Response: Invalid_Request

Table 20 provides a description for this datagram.

Table 23: Response: Invalid_Request Datagram

Description	Encoding	Size of Data (Bytes)	Variable Binding
The monitored equipment received a command that was not understood. No action was taken.	¹ 0x34nn	1	² Contains an error code defining the reason the command was not processed. The following error conditions are defined: 1 = No information available 2 = Invalid COMMAND field from transponder 3 = Invalid SIZE of DATA field from transponder 4 = Invalid VARIABLE BINDING field from transponder

¹nn is the second byte of the command that was not recognized.

²This field can be amended in later revisions of this specification as more error conditions are identified.

4.4.3.10 Response: Request_Processed

Table 24 provides a description for this datagram.

Table 24: Response: Request_Processed Datagram

Description	Encoding	Size of Data (Bytes)	Variable Binding
Acknowledgement from the monitored equipment that the previous command was understood and is being executed. Feedback indicating the requested operation has executed is available in subsequent queries of the Get_Power_Supply_Data response. Some operations may take time to initiate; e.g., starting a generator. Delays should be accounted for when polling for updated status following this Request_Processed response.	¹ 0x35nn	0	[NULL]

¹nn is the second byte of the command being processed.

REFERENCES

TIA/EIA-485-A (ANSI/TIA/EIA-485-A-98). *Electrical Characteristics of Generators and Receivers for Use in Balanced Digital Multipoint Systems*. Telecommunications Industry Association.

SCTE. 2001. *SCTE HMS PS MIB, HMS Power Supply Management Information Base*. Exton, PA: Society of Cable Telecommunications Engineers, Inc.

SCTE. 2001. *SCTE HMS GEN MIB, HMS Power Supply Generator Management Information Base*. Exton, PA: Society of Cable Telecommunications Engineers, Inc.

SCTE. 2000. *Standards Development Annual Report 2000*. Exton, PA: Society of Cable Telecommunications Engineers, Inc.

Appendix A. Glossary

Data Link Layer (DLL)

Layer 2 in the Open System Interconnection (OSI) architecture; the layer that provides services to transfer data over the physical transmission link between open systems.

Network Element (NE)

In the context of this specification, a network element is an active element in the outside plant (OSP) that is capable of receiving commands from a headend element (HE) in the headend and, as necessary, providing status information and alarms back to the HE.

Open System Interconnection (OSI)

A framework of International Organization for Standardization (ISO) standards for communication between multi-vendor systems that organizes the communication process into seven different categories that are placed in a layered sequence based on the relationship to the user. Each layer uses the layer immediately below it and provides services to the layer above. Layers 7 through 4 deal with end-to-end communication between the message source and destination, and layers 3 through 1 deal with network functions.

Physical (PHY) Layer

Layer 1 in the Open System Interconnection (OSI) architecture; the layer that provides services to transmit bits or groups of bits over a transmission link between open systems and which entails electrical, mechanical and handshaking procedures.

Transponder

A device that interfaces to outside plant (OSP) NEs and relays status and alarm information to the HE. It can interface with an active NE via an arrangement of parallel analog, parallel digital and serial ports.

Appendix B. List of Acronyms

DLL.....	Data Link Layer
EMS	Element Management System
HE	Headend Element
HFC.....	Hybrid Fiber Coax
HMS.....	Hybrid Management Sub-Layer
ISO	International Organization for Standardization
NE	Network Element
MAC	Media Access Control
OSP	Outside Plant
OSI.....	Open System Interconnection
PHY.....	Physical
PSTIB.....	Power Supply to Transponder Interface Bus
RF.....	Radio Frequency
SCTE.....	Society of Cable Telecommunications Engineers
SNMP.....	Simple Network Management Protocol
TIA.....	Telecommunications Industry Association

Appendix C. Revision Tracking

This Appendix describes changes/additions/deletions to this document. Each document version is represented as an independent table that describes how the version is unique from the previous version. The most recent version is listed first.

Version 1.1		
Sec//Fig/Tab	Type	Description
Sec 4.1.2 Table 6	Addition	Added “Generators” to the list of items that can be addressed in the range 1-8.
Section 4.1.2 Table 6	Change	Redefined how devices are mapped to the PSTIB addresses in the range 9-255.
Section 4.1.2 Table 6	Addition	The ** footnote was added to explain the use of PSTIB addresses 16-127.
Section 4.3.1	Addition	Added note 5 requiring that transponders periodically re-poll for devices.
Section 4.4.3.2 Table 12	Change	Redefined the value in field 1, the protocol version. Made accommodation for 1 digit to the right of the decimal point.
Section 4.4.3.2 Table 12	Addition	Added note 2 explaining that, unless otherwise indicated, all fields are 8 bits in length.
Section 4.4.3.2.1 Table 13	Addition	Added note 3 explaining that all fields are 8 bits in length.
Section 4.4.3.2.2 Table 14	Addition	Added note 2 explaining that all fields are 8 bits in length.
Section 4.4.3.4 Table 17	Change	Rewrote the definitions for field 22. The original definitions assumed that the inverter is not running when AC is present. This is not true of all power supplies.
Section 4.4.3.4 Table 17	Addition	Added note 1 explaining that all fields are 8 bits in length.
Section 4.4.3.5 Table 18	Addition	Added * and ** footnotes to better define the control of self-test in power supplies.
Section 4.4.3.7 Table 21	Addition	Added note 1 explaining that all fields are 8 bits in length.
Section 4.4.3.8 Table 22	Addition	Added * and ** footnotes to better define the control of self-test in generators.
Appendix B	Addition	Added PSTIB to the Acronyms list.
Appendix C	Addition	Added the entire Appendix.