



***Society of Cable
Telecommunications
Engineers***

**ENGINEERING COMMITTEE
Interface Practices Subcommittee**

AMERICAN NATIONAL STANDARD

ANSI/SCTE 17 2007

**Test Procedure for
Carrier to Noise (C/N, CCN, CIN, CTN)**

NOTICE

The Society of Cable Telecommunications Engineers (SCTE) Standards are intended to serve the public interest by providing specifications, test methods and procedures that promote uniformity of product, interchangeability and ultimately the long term reliability of broadband communications facilities. These documents shall not in any way preclude any member or nonmember of SCTE from manufacturing or selling products not conforming to such documents, nor shall the existence of such standards preclude their voluntary use by those other than SCTE members, whether used domestically or internationally.

SCTE assumes no obligations or liability whatsoever to any party who may adopt the Standards. Such adopting party assumes all risks associated with adoption of these Standards or Recommended Practices, and accepts full responsibility for any damage and/or claims arising from the adoption of such Standards or Recommended Practices.

Attention is called to the possibility that implementation of this standard may require use of subject matter covered by patent rights. By publication of this standard, no position is taken with respect to the existence or validity of any patent rights in connection therewith. SCTE shall not be responsible for identifying patents for which a license may be required or for conducting inquiries into the legal validity or scope of those patents that are brought to its attention.

Patent holders who believe that they hold patents which are essential to the implementation of this standard have been requested to provide information about those patents and any related licensing terms and conditions. Any such declarations made before or after publication of this document are available on the SCTE web site at <http://www.scte.org>.

All Rights Reserved

© Society of Cable Telecommunications Engineers, Inc. 2001, 2007

140 Philips Road

Exton, PA 19341

TABLE OF CONTENTS

1.0	SCOPE AND DEFINITIONS.....	1
2.0	NORMATIVE REFERENCES	2
3.0	EQUIPMENT	2
4.0	SETUP	3
5.0	PROCEDURE.....	4
	APPENDIX 1 - Spectrum Analyzer Corrections For Noise Measurements.	11
	APPENDIX 2 – Example Calculations.....	12

1.0 SCOPE AND DEFINITIONS

1.1 Scope

This procedure defines the measurement procedure for determining the ratio of carrier to thermal noise and “noise-like” interference for broadband telecommunications system components. The test involves measuring the noise levels, or the combined noise plus “noise-like” intermodulation product levels, relative to the carrier level of a CW signal. The noise contribution of the test equipment is also measured to allow for correction of readings near the test equipment noise floor. ANSI/SCTE 96 2003, Cable Telecommunications Testing Guidelines, has additional definitions common to this and other SCTE test procedures.

1.2 Definitions:

1.2.1 Carrier to Noise (C/N):

Traditionally, the term used to describe the ratio of the peak level of the visual carrier of an analog television transmission to the noise floor of the transmission system. This term, when used generically, may refer to the ratio of the carrier to all undesired noise and noise-like signals. The terms CCN, CIN, and CTN are used to more clearly identify the specific components of the noise floor. For this procedure, CW carriers are substituted at equivalent levels to the peak visual carrier levels.

1.2.2 Carrier to Composite Noise (CCN):

The ratio of the CW carrier to the combined noise plus noise-like signal sources of non-thermal origin. This includes the thermal noise (CTN), combined with the noise-like intermodulation products created by beat products of analog and digital signals (CIN)

1.2.3 Carrier to Intermodulation Noise (CIN):

The ratio of the CW carrier to the noise-like signals generated by the non-linearity of a broadband transmission system carrying a combination of analog signals and digitally modulated signals. These distortion products are analogous to the CSO and CTB products generated by analog carriers, but due to the pseudo random nature of the digital modulation signals, appear as a noise-like interference. When CIN products fall within the analog portion of the spectrum, their effect on the analog signal is similar to increasing thermal (random) noise. Since CIN is a distortion product, its contribution is dependant on the output signal level.

1.2.4 Carrier to Thermal Noise (CTN):

The ratio of the CW carrier to the thermal noise floor of the transmission system, specifically excluding any contribution from digital intermodulation products. (Note: for fiber optic systems, this term may include noise components such as shot noise and relative intensity noise (RIN), which are not strictly thermal, but are treated as part of the optical system thermal noise contribution.)

2.0 NORMATIVE REFERENCES

The following document contains provisions, which through reference in this text, constitute provisions of this standard. At the time of publication, editions indicated were valid. All standards are subject to revision, and parties to agreement based on this standard are encouraged to investigate the possibility of applying the most recent editions of the documents listed below.

ANSI/SCTE 96 2003: Cable Telecommunications Testing Guidelines

3.0 EQUIPMENT

ANSI/SCTE 96 2003, Cable Telecommunications Testing Guidelines, describes and specifies the required test equipment in more detail.

3.1 Required Test Equipment

- Signal Sources:
 - Multi-carrier RF generator
 - Digital signal sources (modulators) or filtered noise source
- RF Amplifier: (if necessary)
 - Gain \cong 10 to 20 dB
 - NF \leq 10 dB
- RF Attenuators:
 - 75 Ω switchable attenuator(s):
 - 1 dB steps, 0 - 10 dB range
 - 10 dB steps, 0 - 70 dB range
 - 75 Ω fixed attenuator(s): 3, 6, 10 & 20 dB values
- Spectrum analyzer
- Interconnect cables and connectors
- Band Pass Filter (BPF), fixed or tunable, centered around carrier under test

4.0 SETUP

- 4.1 Follow all pre-test calibration requirements recommended by the manufacturers of the signal generators and spectrum analyzer, including adequate warm-up and stabilization time.
- 4.2 Connect the test equipment as shown in figure 1.
- 4.3 Set the signal generators to provide all of the signals needed for the test, at the desired levels. If appropriate, power the Device Under Test (DUT) under its normal operating conditions. Note that the DUT may consist of a single device or a group of devices connected together as a system.

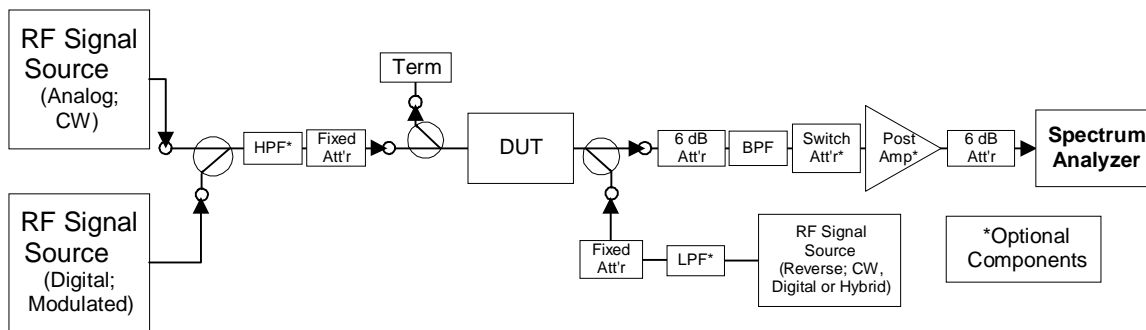

Figure 1: Test Equipment Setup

5.0 PROCEDURE

A flowchart of the test procedure is shown in figure 2. The numbers to the left of the blocks reference the procedure steps.

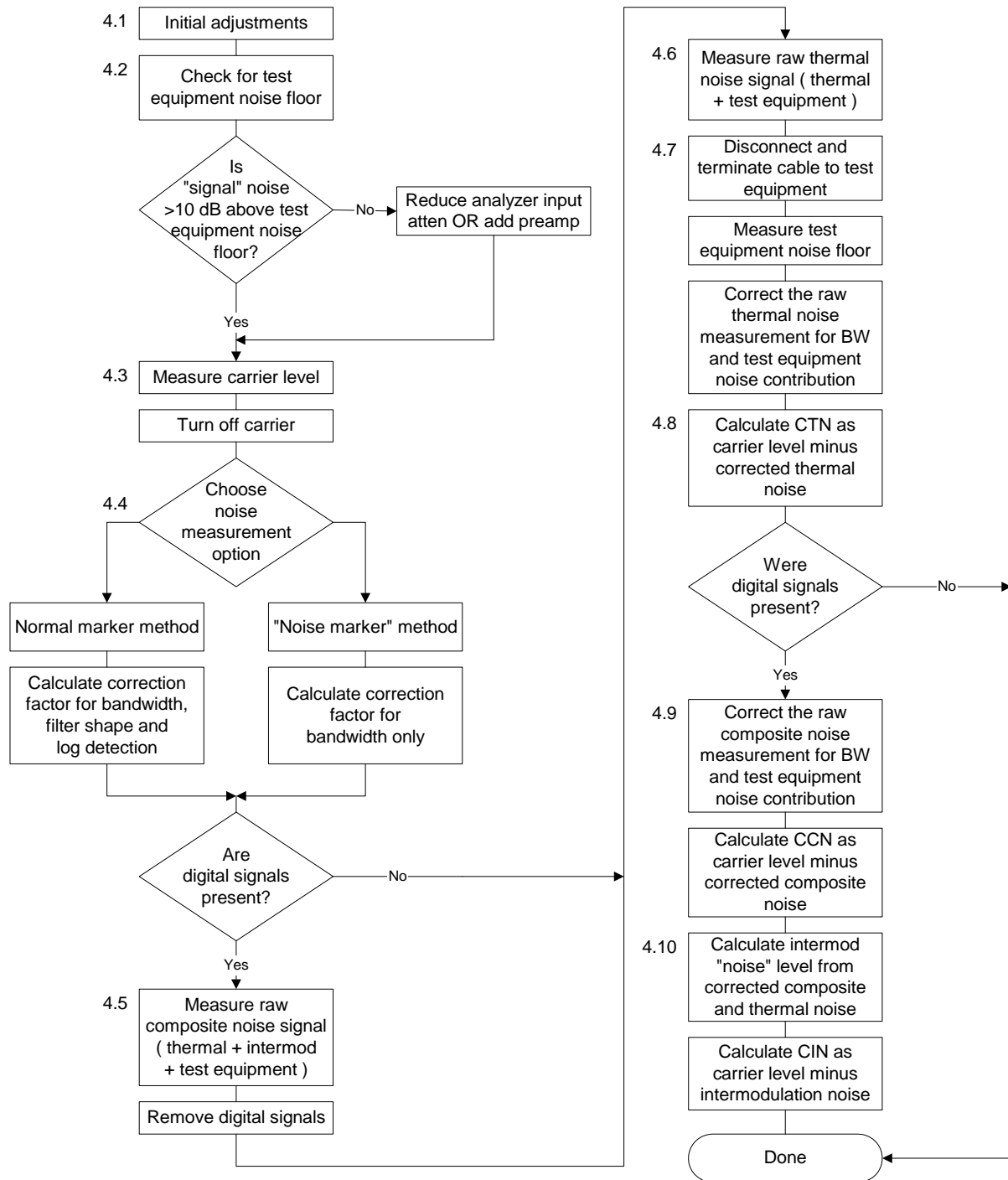

Figure 2: Flowchart for Carrier to Noise Measurements

5.1 Initial Adjustments

5.1.1 Adjust the spectrum analyzer settings as follows:

Center Frequency	Carrier frequency of channel under test
Frequency Span	30 MHz
Resolution Bandwidth	30 kHz
Video Bandwidth	10 kHz
Video Averaging	Off
Input Attenuation	Auto (minimum 10 dB to start)
Vertical Scale	10 dB/div.
Detector	Peak detection

5.1.2 Adjust the bandpass filter to peak and center the channel under test. The adjacent carriers on both sides should be equally rejected, at least 10 dB relative to the channel under test.

5.1.3 Re-adjust the spectrum analyzer as follows:

Frequency Span	3 MHz
Video Bandwidth	30 Hz (or lower if sweep time is tolerable)

5.1.4 The noise floor should appear flat across the display, excluding local peaks for CTB and CSO.

5.2 Check for Test Equipment Noise Floor

5.2.1 Observe the level of the "signal" noise from the DUT.

5.2.2 Disconnect and terminate the cable going to the test equipment from the DUT output.

5.2.3 If the noise floor drop is less than 10 dB, reduce the spectrum analyzer internal input attenuator and re-check the noise drop. Be sure to compare the "signal" noise to test equipment noise with the same attenuator setting.

5.2.4 If with the spectrum analyzer input attenuator set to 0 dB the noise floor drop is still less than 10 dB, then the use of the optional spectrum analyzer preamp is recommended.

Note: It is not unusual to have less than a 10 dB noise delta, even with the preamp. A correction factor can be applied to correct for the test equipment noise contribution.

5.2.5 Reconnect the test cable.

5.3 Measure Carrier Level

5.3.1 Re-adjust the spectrum analyzer as follows:

Video Bandwidth	10 kHz
-----------------	--------

5.3.2 Adjust the spectrum analyzer reference level to place the peak of the channel under test in the upper two divisions of the display. The input attenuator setting may be adjusted for the carrier level measurement, but must be returned to the setting determined in Section 5.2.3 afterwards. Changing the input attenuator setting may affect the measurement results by the incremental accuracy of the attenuator.

5.3.3 Set the marker to read carrier peak.

5.3.4 Measure and record the carrier peak, C_p , in dBmV.

5.3.5 Turn off the carrier for the channel under test.

5.4 Choose Noise Measurement Option

Normal Marker Method: This method uses the spectrum analyzer marker in normal mode. The marker will display the noise level in the resolution bandwidth being used.

Noise Marker Method: This method uses the spectrum analyzer marker set to "Noise Marker". The marker will display the noise level normalized to a 1 Hz bandwidth.

5.4.1 Select a method to be used for the noise measurements.

5.4.2 Look up or calculate the correction factor, COR_{BW} , to correct the noise measurement for the system bandwidth. See appendix 1 for more details. This correction will be used in steps 5.8.1 and 5.9.1.

System BW	Normal Marker Correction	Noise Marker Correction
4 MHz	23.3 dB	66.0 dB
5 MHz	24.3 dB	67.0 dB

Table 1- Analyzer BW Correction for HP 8591x

5.5 Measurement of Raw Composite Noise

[Note: If only analog carriers are being used for the test, this section is skipped.]

This is the measurement of the raw combined thermal noise plus digital intermodulation components, prior to corrections for resolution bandwidth and test equipment noise contribution.

5.5.1 Re-adjust the spectrum analyzer as follows:

Video Bandwidth	30 Hz (or lower if sweep time is tolerable)
Video Averaging (optional)	Multiple sweep averaging
Detector	Sample detection

5.5.2 Move the marker to read a flat portion of the noise floor, between the peaks for any CTB or CSO. In some analyzers, the noise marker function averages multiple points around the displayed marker value. Therefore, the noise marker should be placed at least one half a horizontal division away from any non-flat area. If desired, the frequency span may be adjusted to spread out the flat portion of the noise floor. The resolution bandwidth must remain set to 30 kHz.

5.5.3 Measure and record the average Raw Composite Noise level, $N_{\text{COMP-raw}}$, in dBmV.

5.5.4 Remove the digital signal source, and terminate the combining point.

5.6 Measurement of Raw Thermal Noise

This is the measurement of the DUT raw thermal noise, prior to corrections for resolution bandwidth and test equipment noise contribution.

5.6.1 Re-adjust the spectrum analyzer as follows:

Video Bandwidth	30 Hz (or lower if sweep time is tolerable)
Video Averaging (optional)	Multiple sweep averaging
Detector	Sample detection

5.6.2 Move the marker to read a flat portion of the noise floor, between the peaks for any CTB or CSO. In some analyzers, the noise marker function averages multiple points around the displayed marker value. Therefore, the noise marker should be placed at least one half a horizontal division away from any non-flat area. If desired, the frequency span may be adjusted to spread out the flat portion of the noise floor. The resolution bandwidth must remain set to 30 kHz.

5.6.3 Measure and record the average Raw Thermal Noise level, $N_{\text{TH-raw}}$, in dBmV.

[Note: This procedure assumes no significant noise contribution from the RF Signal Sources.]

5.7 Measurement of Test Equipment Noise floor

This measurement is made to determine if any correction should be applied to the earlier measurements to account for the contribution of test equipment noise.

- 5.7.1 Disconnect the Device under test at its output, and terminate the cable that goes to the test equipment.
- 5.7.2 Measure and record the Test Equipment Noise Floor, N_{TE} , in dBmV.
- 5.7.3 Determine the difference (in dB) between the measured Test Equipment Noise and the previously measured Composite Noise and Thermal Noise

$$N_{drop1} = N_{COMP-raw} - N_{TE} \quad (1)$$

$$N_{drop2} = N_{TH-raw} - N_{TE} \quad (2)$$

- 5.7.4 If the test equipment noise floor drop is greater than 2 dB a correction factor can be applied to the noise measurements. Determine the correction factor from the formulae or from Table 2:

$$COR_{drop1} = \left| 10 \cdot \log \left(1 - 10^{-\left(\frac{N_{drop1}}{10}\right)} \right) \right| \quad (3)$$

$$COR_{drop2} = \left| 10 \cdot \log \left(1 - 10^{-\left(\frac{N_{drop2}}{10}\right)} \right) \right| \quad (4)$$

Noise Drop (dB)	Noise Correction (dB)	Noise Drop in dB	Noise Correction (dB)
2.0	4.3	8.0	0.7
2.5	3.6	9.0	0.6
3.0	3.0	10.0	0.5
3.5	2.6	11.0	0.4
4.0	2.2	12.0	0.3
5.0	1.7	13.0	0.2
6.0	1.3	14.0	0.2
7.0	1.0	15.0	0.1

Table 2 – Noise near Noise Corrections

- 5.7.5 If the test equipment noise floor drop is less than 2 dB, then see ANSI/SCTE 96 2003 for the limits on noise near noise corrections.
- 5.7.6 If the test equipment noise floor drop is greater than 15 dB, then the correction factor is insignificant.

5.8 Calculation of Carrier to Thermal Noise (CTN)

- 5.8.1 Calculate the corrected thermal noise signal, N_{TH} , by applying the correction factors for measurement BW (from 5.4) and for test equipment noise contribution (from 5.7) to the measured raw thermal noise.

$$N_{TH} = N_{TH-raw} + COR_{BW} - COR_{drop2} \quad (5)$$

- 5.8.2 Calculate the Carrier to Thermal Noise (CTN) by taking the difference between the measured carrier level and the corrected thermal noise signal level.

$$CTN = C_P - N_{TH} \quad (6)$$

5.9 Calculation of Carrier to Composite Noise (CCN)

[Note: If only analog carriers are being used for the test, this section is skipped.]

- 5.9.1 Calculate the corrected composite noise signal, N_C , by applying the correction factors for measurement BW (from 5.4) and for test equipment noise contribution (from 5.7) to the measured raw thermal noise.

$$N_{COMP} = N_{COMP-raw} + COR_{BW} - COR_{drop1} \quad (7)$$

- 5.9.2 Calculate the Carrier to Composite Noise (CCN) by taking the difference between the measured carrier level and the corrected composite noise signal level.

$$CCN = C_P - N_{COMP} \quad (8)$$

5.10 Calculation of Carrier to Intermodulation Noise (CIN)

[Note: If only analog carriers are being used for the test, this section is skipped.]

- 5.10.1 Calculate the digital intermodulation “noise” signal, N_{DIG} from the corrected composite noise and corrected thermal noise.

$$N_{DIG} = 10 \cdot \log\left(10^{(N_{COMP}/10)} - 10^{(N_{TH}/10)}\right) \quad (9)$$

- 5.10.2 Calculate the Carrier to Intermodulation Noise (CIN) by taking the difference between the measured carrier level and the calculated digital intermodulation signal.

$$CIN = C_P - N_{DIG} \quad (10)$$

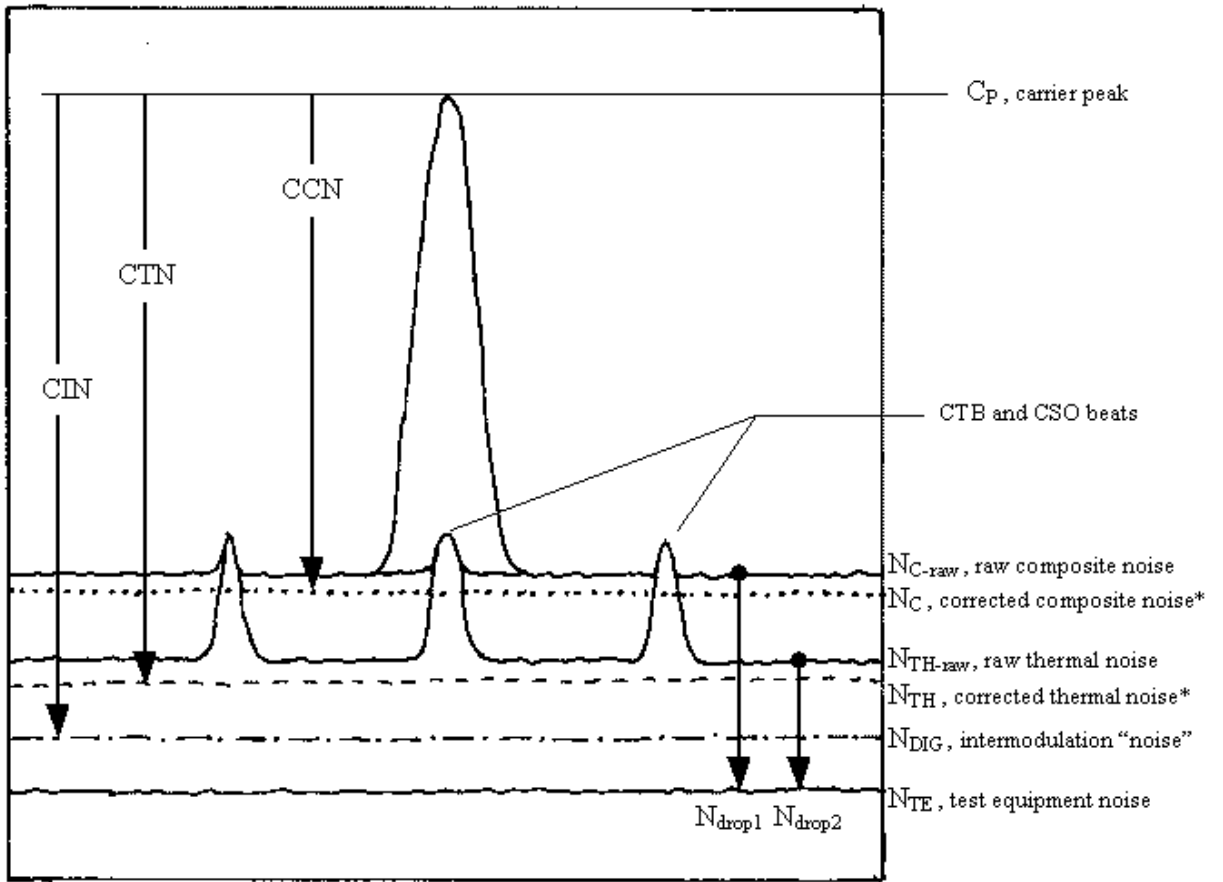

Figure 2 - Sketch of Noise Components

* The corrections shown here are for test equipment noise contribution only, bandwidth corrections are not shown.

APPENDIX 1 - Spectrum Analyzer Corrections For Noise Measurements.

For NTSC format, the carrier to noise (C/N) is defined within a 4 MHz bandwidth. Since the measurements are made using a spectrum analyzer set to 30 kHz resolution bandwidth, a correction must be applied to account for the analyzer bandwidth setting, the internal IF filter shape, and the analyzer detection method.

Normal Marker Method: This method uses the spectrum analyzer marker in normal mode. The marker will display the noise level in the resolution bandwidth being used.

$$\text{COR}_{\text{BW}} = 10 \cdot \log \left(\frac{\text{Noise BW}}{\text{Filter Shape Factor} \cdot \text{Res BW}} \right) + \text{Log Amp Factor} \quad (\text{A1})$$

Noise BW =	Desired Noise Bandwidth (4.0 MHz for NTSC)
Filter Shape Factor =	Filter correction based on noise power passed versus a true square-sided noise filter (to be supplied by spectrum analyzer vendor)
Res BW =	Spectrum analyzer's resolution bandwidth
Log Amp Factor =	Correction for log amplifier and Rayleigh distribution errors (nominally 2.5 dB)

Example:

Analyzer Type	Hewlett Packard 8591E
Filter Shape Factor	1.12
Log Amp Factor	2.5 dB
Resolution Bandwidth	30 kHz
Noise BW	4 MHz

$$\text{COR}_{\text{BW}} = 10 \cdot \log \left(\frac{4 \text{ MHz}}{1.12 \times 30 \text{ kHz}} \right) + 2.5 \text{ dB} = 23.25 \text{ dB}$$

Noise Marker Method: This method uses the spectrum analyzer marker set to "Noise Marker". The marker will display the measured noise level normalized to a 1 Hz bandwidth. The correction factors for the IF filter shape and log amp factors have already been included in the spectrum analyzer programming. Only the bandwidth correction is needed.

$$\text{COR}_{\text{BW}} = 10 \cdot \log \left(\frac{\text{Noise BW}}{1 \text{ Hz}} \right) \quad (\text{A2})$$

Example:

Noise BW	NTSC (4 MHz)
----------	--------------

$$\text{COR}_{\text{BW}} = 10 \cdot \log \left(\frac{4 \text{ MHz}}{1 \text{ Hz}} \right) = 66.0 \text{ dB}$$

APPENDIX 2 – Example Calculations

Example 1: Normal Marker Method:

Step	Measurement or Calculation
4.3	$C_p = 48.0 \text{ dBmV}$ (measured)
4.4	$COR_{BW} = 23.3 \text{ dB}$ (from table 1)
4.5	$N_{COMP-raw} = -26.0 \text{ dBmV}$ (measured)
4.6	$N_{TH-raw} = -27.0 \text{ dBmV}$ (measured)
4.7	$N_{TE} = -35.0 \text{ dBmV}$ (measured)
	$N_{drop1} = N_{COMP-raw} - N_{TE}$
	$= -26.0 - (-35.0)$
	$= 9.0 \text{ dB}$
	$N_{drop2} = N_{TH-raw} - N_{TE}$
	$= -27.0 - (-35.0)$
	$= 8.0 \text{ dB}$
	$COR_{drop1} = 0.6 \text{ dB}$ (from table 2)
	$COR_{drop2} = 0.7 \text{ dB}$ (from table 2)
4.8	$N_{TH} = N_{TH-raw} + COR_{BW} - COR_{drop2}$
	$= -27.0 + 23.3 - 0.7$
	$= -4.4 \text{ dBmV}$
	$CTN = C_p - N_{TH}$
	$= 48.0 - (-4.4)$
	<u>CTN = 52.4 dB</u>
4.9	$N_{COMP} = N_{COMP-raw} + COR_{BW} - COR_{drop1}$
	$= -26.0 + 23.3 - 0.6$
	$= -3.3 \text{ dBmV}$
	$CCN = C_p - N_{COMP}$
	$= 48.0 - (-3.3)$
	<u>CCN = 51.3 dB</u>
4.10	$N_{DIG} = 10 \cdot \log(10^{(N_{COMP}/10)} - 10^{(N_{TH}/10)})$
	$= 10 \cdot \log(10^{(-3.3/10)} - 10^{(-4.4/10)})$
	$= 10 \cdot \log(0.4677 - 0.3631)$
	$= 10 \cdot \log(0.1046)$
	$= -9.8 \text{ dBmV}$
	$CIN = C_p - N_{DIG}$
	$= 48.0 - (-9.8)$
	<u>CIN = 57.8 dB</u>

Example 2: Noise Marker Method:

Step	Measurement or Calculation
4.3	$C_p = 48.0 \text{ dBmV}$ (measured)
4.4	$COR_{BW} = 66.0 \text{ dB}$ (from table 1)
4.5	$N_{COMP-raw} = -68.7 \text{ dBmV}$ (measured)
4.6	$N_{TH-raw} = -69.7 \text{ dBmV}$ (measured)
4.7	$N_{TE} = -77.7 \text{ dBmV}$ (measured)
	$N_{drop1} = N_{COMP-raw} - N_{TE}$
	$= -68.7 - (-77.7)$
	$= 9.0 \text{ dB}$
	$N_{drop2} = N_{TH-raw} - N_{TE}$
	$= -69.7 - (-77.7)$
	$= 8.0 \text{ dB}$
	$COR_{drop1} = 0.6 \text{ dB}$ (from table 2)
	$COR_{drop2} = 0.7 \text{ dB}$ (from table 2)
4.8	$N_{TH} = N_{TH-raw} + COR_{BW} - COR_{drop2}$
	$= -69.7 + 66.0 - 0.7$
	$= -4.4 \text{ dBmV}$
	$CTN = C_p - N_{TH}$
	$= 48.0 - (-4.4)$
	<u>CTN = 52.4 dB</u>
4.9	$N_{COMP} = N_{COMP-raw} + COR_{BW} - COR_{drop1}$
	$= -68.7 + 66.0 - 0.6$
	$= -3.3 \text{ dBmV}$
	$CCN = C_p - N_{COMP}$
	$= 48.0 - (-3.3)$
	<u>CCN = 51.3 dB</u>
4.10	$N_{DIG} = 10 \cdot \log(10^{(N_{COMP}/10)} - 10^{(N_{TH}/10)})$
	$= 10 \cdot \log(10^{(-3.3/10)} - 10^{(-4.4/10)})$
	$= 10 \cdot \log(0.4677 - 0.3631)$
	$= 10 \cdot \log(0.1046)$
	$= -9.8 \text{ dBmV}$
	$CIN = C_p - N_{DIG}$
	$= 48.0 - (-9.8)$
	<u>CIN = 57.8 dB</u>