



***Society of Cable  
Telecommunications  
Engineers***

---

**ENGINEERING COMMITTEE  
Interface Practices Subcommittee**

---

**AMERICAN NATIONAL STANDARD**

**ANSI/SCTE 153 2008**

**Drop Passives: Splitters, Couplers and Power Inserters**

## NOTICE

The Society of Cable Telecommunications Engineers (SCTE) Standards are intended to serve the public interest by providing specifications, test methods and procedures that promote uniformity of product, interchangeability and ultimately the long term reliability of broadband communications facilities. These documents shall not in any way preclude any member or non-member of SCTE from manufacturing or selling products not conforming to such documents, nor shall the existence of such standards preclude their voluntary use by those other than SCTE members, whether used domestically or internationally.

SCTE assumes no obligations or liability whatsoever to any party who may adopt the Standards. Such adopting party assumes all risks associated with adoption of these Standards, and accepts full responsibility for any damage and/or claims arising from the adoption of such Standards.

Attention is called to the possibility that implementation of this standard may require the use of subject matter covered by patent rights. By publication of this standard, no position is taken with respect to the existence or validity of any patent rights in connection therewith. SCTE shall not be responsible for identifying patents for which a license may be required or for conducting inquiries into the legal validity or scope of those patents that are brought to its attention.

Patent holders who believe that they hold patents which are essential to the implementation of this standard have been requested to provide information about those patents and any related licensing terms and conditions. Any such declarations made before or after publication of this document are available on the SCTE web site at <http://www.scte.org>.

All Rights Reserved

© Society of Cable Telecommunications Engineers, Inc. 2008  
140 Philips Road  
Exton, PA 19341

## TABLE OF CONTENTS

|     |   |          |
|-----|---|----------|
| 1.0 | SCOPE .....   | 1        |
| 2.0 | MECHANICAL .....  | 1        |
| 3.0 | ELECTRICAL .....  | 4        |
| 4.0 | ENVIRONMENTAL .....   | 7        |
| 5.0 | NORMATIVE REFERENCES .....  | 7        |
|     |   |          |
|     | <b>Figure 1: Orthogonal Mounting of Device on 0.500" Hole Pattern</b> | <b>2</b> |
|     | <b>Figure 2: Example of Conforming Labeling</b>                       | <b>3</b> |
|     |   |          |
|     | <b>Table 1: Allowable Insertion Loss</b>                              | <b>4</b> |
|     | <b>Table 2: Minimum Port to Port Isolation</b>                        | <b>5</b> |

## **1.0 SCOPE**

The purpose of this document is to recommend mechanical, environmental and electrical standards for broadband radio frequency (RF) devices whose primary purpose is to divide signals presented to an input port among two or more output ports with a fixed division ratio that is nominally independent of frequency within the specified bandwidth limits of the device. Alternately, such devices can be used to combine signals from several input ports into a common output port. Its scope is limited to 75-ohm devices whose ports are provided with type F connectors. The most common use for such devices is on-premises RF signal distribution.

Products covered by this specification include signal splitters (2,3,4 and 8-way), directional couplers, combined splitter/directional couplers and power inserters.

Two levels of compliance are specified. Devices meeting all electrical, mechanical and environmental specifications may be specified as meeting the requirements of this specification without qualification. Those meeting electrical and mechanical, but not environmental requirements may be designated as meeting this specification with the suffix "Indoor Use Only " and the products must be marked as specified herein to guide users in their appropriate application.

The specification is not intended to apply to specialty devices, nor is it intended to limit or restrict any manufacturer's innovation and improvement.

## **2.0 MECHANICAL**

### **2.1 RF Ports**

- 2.1.1 RF ports on devices intended for indoor applications must conform to the requirements of ANSI/SCTE 02 2006.
- 2.1.2 RF ports on devices intended to be rated for outdoor use must conform to the requirements of ANSI/SCTE 01 2006.
- 2.1.3 Where more than one connector exits from a common surface of the device, connectors will be spaced a minimum of 0.925" apart, center-to-center.

## 2.2 Mounting

Mounting holes or slots may be located at the manufacturers preferred locations provided that they meet the requirements of 2.2.1 and 2.2.2 herein.

- 2.2.1 Mounting holes or slots shall be of such size and location as to allow orthogonal mounting of the device on a hole pattern grid of 0.500" by 0.500" (12.7mm x 12.7mm), capable of employing standard #6 (M3.5) hardware. (Figure 1)
- 2.2.2 Mounting holes, slots or Bonding points shall be located as to not interfere with open-end wrench access to the F ports.

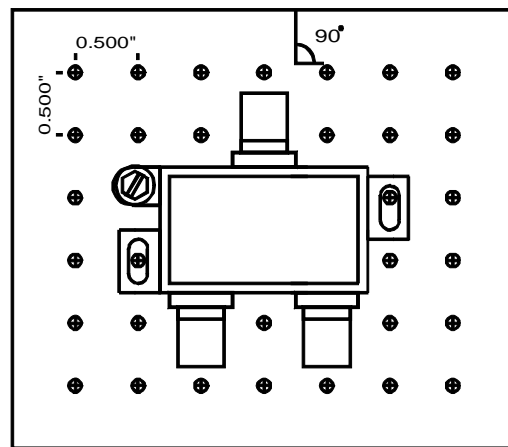

**Figure 1: Orthogonal Mounting of Device on 0.500" Hole Pattern**

## 2.3 Bond Wire Attachment

- 2.3.1 Outdoor-rated units must be equipped with an integral bonding wire attachment point.
- 2.3.2 Integral Bonding Wire point must conform to the requirements of ANSI/SCTE 129 2007, Section 2.3

## 2.4 Labeling

Each port of the device must be labeled. Designations must be in accordance with the following:

- 2.4.1 The common port may be labeled "COMMON", "IN" or "INPUT" at the manufacturer's option.

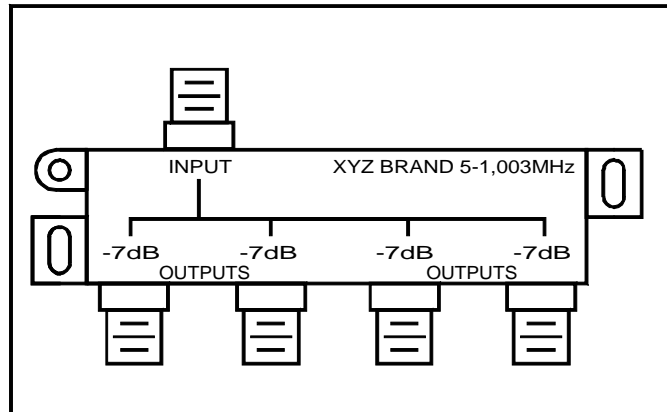

**Figure 2: Example of Conforming Labeling**

- 2.4.2 In the case of splitters, each of the splitter output ports may be labeled “OUT” or “OUTPUT” and may include a port number at the manufacturers option. Each port must also indicate the nominal loss from the input to that port in the form “-n dB” where n is the nominal loss. The “Nominal Loss” is the manufacturer's specified highest rated frequency loss rounded up to the next 0.5dB.
- 2.4.3 In the case of directional couplers, the port receiving the greatest percentage of the input signal may be labeled “THRU”, “THROUGH”, “OUT”, “OUTPUT” or other clearly understood term, at the manufacturers option. The port receiving the lower percentage of the input signal shall be labeled “TAP” and must also be labeled with the nominal loss from the input in the form “-n dB”, where “n” is the nominal loss in dB.
- 2.4.4 In the case of Power Inserters, the Power port may be labeled as "DC", "AC" or "PWR". The port with RF only should be labeled "RF" or "TV", and the port with power and RF should be labeled "RF + PWR", "AC", or other clearly understood term, at the manufacturers option. Maximum voltage must also be stated.
- 2.4.5 So long as the function of each port is clear and the loss from the input to each output port is clear, manufacturers may use any labeling layout they choose. See Figure 2 for an example of conforming labeling.
- 2.4.6 All labels must incorporate the manufacturers model number and rated bandwidth of the device.

2.4.7 Devices which do not meet the environmental criteria as specified in section 4.2 shall be labeled “For Indoor Use Only”.

2.4.8 Labeling shall be designed to be legible for a period of at least 10 years under typical environmental exposure and handling

### **3.0 ELECTRICAL**

3.1 Bandwidth. All devices shall be designed to operate over a bandwidth of at least 5 to 1002 MHz.

3.2 Passband Response. The Passband response measured from the input port to any output port shall not exceed  $\pm 0.5$  dB relative to the slope loss of the device as measured and defined in ANSI/SCTE 144 2007.

3.3 Insertion Loss. The insertion loss of the device, measured from the input port to the designated output port, with all other ports terminated, shall not exceed the values specified in Table 1. All measurements shall be made using the methods specified in ANSI/SCTE 144 2007:

**Table 1: Allowable Insertion Loss**

| TABLE 1<br>DEVICE | INSERTION<br>LOSS FROM<br>INPUT PORT<br>TO: | LOSS (dB)/FREQUENCY (MHz) |         |           |
|-------------------|---|---------------------------|---------|-----------|
|                   |   | 5-400                     | 400-600 | 600-1,002 |
| 2-WAY SPLITTER    | ANY OUTPUT                                  | ≤3.6                      | ≤4.0    | ≤4.4      |
| 3-WAY BALANCED    | ANY OUTPUT                                  | ≤6.1                      | ≤6.5    | ≤7.0      |
| 3-WAY UNBALANCED  | HI OUTPUT                                   | ≤3.6                      | ≤4.0    | ≤4.4      |
|                   | LOW OUTPUTS                                 | ≤7.2                      | ≤7.8    | ≤8.8      |
| 4-WAY SPLITTER    | ANY OUTPUT                                  | ≤7.2                      | ≤7.8    | ≤8.8      |
| 8-WAY SPLITTER    | ANY OUTPUT                                  | ≤11.0                     | ≤12.0   | ≤13.2     |
| 16-WAY SPLITTER   | ANY OUTPUT                                  | ≤15.0                     | ≤16.0   | ≤17.6     |
| 6dB COUPLER       | THROUGH                                     | ≤1.8                      | ≤2.2    | ≤2.8      |
|                   | TAP   | 6.0±1                     |         |           |
| 9dB COUPLER       | THROUGH                                     | ≤1.4                      | ≤1.8    | ≤2.1      |
|                   | TAP   | 9.0±1                     |         |           |
| 12dB COUPLER      | THROUGH                                     | ≤1.0                      | ≤1.2    | ≤1.7      |
|                   | TAP   | 12.0±1                    |         |           |
| 16dB COUPLER      | THROUGH                                     | ≤0.8                      | ≤0.9    | ≤1.5      |
|                   | TAP   | 16.0±1                    |         |           |
| 20dB COUPLER      | THROUGH                                     | ≤0.8                      | ≤0.9    | ≤1.4      |
|                   | TAP   | 20.0±1                    |         |           |
| 24dB COUPLER      | THROUGH                                     | ≤0.7                      | ≤0.8    | ≤1.2      |
|                   | TAP   | 24.0±1                    |         |           |
| 27dB COUPLER      | THROUGH                                     | ≤0.7                      | ≤0.8    | ≤1.2      |
|                   | TAP   | 27.0±1                    |         |           |
| 30dB COUPLER      | THROUGH                                     | ≤0.7                      | ≤0.8    | ≤1.2      |
|                   | TAP   | 30.0±1                    |         |           |
| POWER INSERTER    | OUTPUT                                      | ≤0.7                      | ≤0.8    | ≤1.2      |

- 3.4 Return Loss. The return loss, as measured at any RF port, with all other ports terminated, shall be a minimum of 18 dB. All measurements shall be made in accordance with the procedures outlined in ANSI/SCTE 144 2007.
- 3.5 Isolation. The isolation between any two RF output ports, with all other ports terminated, shall be as defined in Table 2. Measurements shall be made using the procedures specified in ANSI/SCTE 144 2007.

| TABLE 2<br>DEVICE        | MINIMUM OUTPUT PORT TO OUTPUT PORT ISOLATION |          |           |              |
|--------------------------|--|----------|-----------|--------------|
|                          | 5-10MHz                                      | 10-65MHz | 65-870MHz | 870-1,002MHz |
| SPLITTERS/COUPLERS (ALL) | ≥22dB  | ≥30dB    | ≥26dB     | ≥23dB        |

**Table 2: Minimum Port to Port Isolation**

- 3.6 Shielding Effectiveness. The shielding effectiveness of components when measured in accordance with ANSI/SCTE 48-2 2008 shall be a minimum of 100dB.
  - 3.6.1 Power Inserters will be tested with associated power supply connected, and shielding measured along the power carrying cable and the power supply.
- 3.7 Surge Withstand. The surge withstand of components when measured in accordance with ANSI/SCTE 81 2007 shall be at minimum compliant with IEEE C62.41-1991 Category A3, Ring Wave 6KV at the F Ports. Power Inserter and associated power supply shall be connected together and subjected to IEEE C62.41-1991 Category B3, Combination Wave 6KV applied to the Mains plug.
- 3.8 Intermodulation Distortion. The Intermodulation Distortion of the device must be better than -95dB relative to the injected signal when tested in accordance with SCTE 145 2008. Intermodulation Tests shall be performed immediately after Surge Withstand Test in order to test for any Ferrite Magnetization detrimental effects.

## **4.0 ENVIRONMENTAL**

- 4.1 Applicability. The following requirements apply for all devices. Devices which do not meet the requirement in section 4.2 shall be labeled “For Indoor Use Only”.
- 4.2 Salt Spray. The device must meet all performance requirement as outlined in section 3, after a minimum of 1000 hours of salt spray when tested in accordance with ANSI/SCTE 143 2007. The device must exhibit corrosion penetration of less than 50% metal thickness, and show no evidence of internal damage. F Ports shall be appropriately sealed during testing to prevent Salt Water compound entry via the ports.
- 4.3 Temperature. The device must meet all performance requirement during and after temperature cycles ranging from -40°F (-40°C) to +140°F (+60°C) inclusive (Outdoor Rated Devices), and +32°F (0°C) to +140°F (+60°C) inclusive (Indoor Rated Devices) with 95% relative humidity at both types of devices at the high temperature limit.

Temperature Cycles Shall be:

- 2 hrs at the low limit
- 1hr transition to high limit
- 2hrs at the high limit
- 1 hr transition to the low limit Repeat for 15 cycles

## **5.0 NORMATIVE REFERENCES**

The following documents contain provisions, which, through reference in this text, constitute provisions of this standard. At the time of publication, the editions indicated were valid. All standards are subject to revision, and parties to agreement based on this standard are encouraged to investigate the possibility of applying the most recent editions of the documents listed below.

### **5.1 SCTE References**

1. ANSI/SCTE 01 2006: “F” Port (Female Outdoor) Physical Dimensions.
2. ANSI/SCTE 02 2006: “F” Port (Female Indoor) Physical Dimensions.
3. ANSI/SCTE 129 2007 SCTE Standard for Bonding Blocks (Without Surge protection)
4. ANSI/SCTE 81 2007: Surge Withstand Test Procedure

5. ANSI/SCTE 48-2 2008: Test Procedure for Measuring Relative Shielding Properties of Active and Passive Coaxial Cable Devices Using Agilent Magnetic Close Field Probe
6. ANSI/SCTE 144 2007: Test Procedure for Transmission and Reflection
7. ANSI/SCTE 145 2008: Second Harmonic Testing Using a Single Carrier
8. ANSI/SCTE 143 2007: Test Method for Salt Spray

## 5.2 Standards from other Organizations

10. IEEE C62.41-1991: "IEEE Recommended Practice for Surge Voltages in Low Voltage AC Power Circuits"