



***Society of Cable
Telecommunications
Engineers***

**ENGINEERING COMMITTEE
Interface Practices Subcommittee**

AMERICAN NATIONAL STANDARD

ANSI/SCTE 145 2008

**Test Method for Second Harmonic Distortion of Passives
Using a Single Carrier**

NOTICE

The Society of Cable Telecommunications Engineers (SCTE) Standards are intended to serve the public interest by providing specifications, test methods and procedures that promote uniformity of product, interchangeability and ultimately the long term reliability of broadband communications facilities. These documents shall not in any way preclude any member or nonmember of SCTE from manufacturing or selling products not conforming to such documents, nor shall the existence of such standards preclude their voluntary use by those other than SCTE members, whether used domestically or internationally.

SCTE assumes no obligations or liability whatsoever to any party who may adopt the Standards. Such adopting party assumes all risks associated with adoption of these Standards or Recommended Practices, and accepts full responsibility for any damage and/or claims arising from the adoption of such Standards or Recommended Practices.

Attention is called to the possibility that implementation of this standard may require use of subject matter covered by patent rights. By publication of this standard, no position is taken with respect to the existence or validity of any patent rights in connection therewith. SCTE shall not be responsible for identifying patents for which a license may be required or for conducting inquiries into the legal validity or scope of those patents that are brought to its attention.

Patent holders who believe that they hold patents which are essential to the implementation of this standard have been requested to provide information about those patents and any related licensing terms and conditions. Any such declarations made before or after publication of this document are available on the SCTE web site at <http://www.scte.org>.

All Rights Reserved

© Society of Cable Telecommunications Engineers, Inc. 2008

140 Philips Road

Exton, PA 19341

TABLE OF CONTENTS

1.0	SCOPE AND DEFINITIONS.....	1
2.0	INFORMATIVE REFERENCES.....	2
3.0	EQUIPMENT	3
4.0	SET-UP.....	4
5.0	PROCEDURE.....	6
6.0	REPORT FORM.....	9

LIST OF FIGURES

FIGURE 1 - SECOND HARMONIC DISTORTION TEST SET-UP	4
FIGURE 2 - TEST SET-UP TO SET AND VERIFY CARRIER SIGNAL LEVEL	6
FIGURE 3 - TEST SET-UP TO MEASURE LEVEL OF SECOND HARMONIC DISTORTION PRESENT WITHOUT THE DEVICE UNDER TEST (DUT).	8

1.0 SCOPE AND DEFINITIONS

- 1.1 The purpose of this document is to establish the standard methodology to measure second harmonic distortion in a Cable Telecommunication System passive at high signal level conditions (50 – 60 dBmV). Due to the difficulty in acquiring multi-carrier signal generators with both 55 dBmV output and intermod beats at –120 dBc, the test procedure will use a single carrier source test method.
- 1.2 The area of concern for most Cable Telecommunication Systems are the high power signals sent in the return path (5 – 42 MHz.). Therefore, this document limits the testing to signals in the 5 – 42 MHz. range.
- 1.3 Second harmonic: A waveform generated at twice the frequency as the original. Such distortion can occur when one or more carriers pass through a nonlinear device.
- 1.4 Second Harmonic Distortion (SHD) is defined as the ratio of the second harmonic signal level to the fundamental carrier signal level at the Device Under Test (DUT) output.
- 1.5 Please note that this procedure is a very unique procedure for measuring second harmonic distortion of passives using a single carrier source test method and distinguishes itself from other similar procedures in the following ways:
 - Designed for Passives
 - Two port measurement
 - Inject return frequency into input and measure 2nd harmonic at output
 - Used to test for distortion caused by core saturation. Designed to be consistent with the mechanisms that have caused problems in outside plant -- large reverse carriers causing distortion in channels 2 through 5.

2.0 INFORMATIVE REFERENCES

The following documents may provide valuable information to the reader but are not required when complying with this standard.

- 2.1 ANSI/SCTE 115 2006: Test Method for Reverse Path (Upstream) Intermodulation Using Two Carriers

2.2 ANSI/SCTE 126 2006: Test Method for Distortion of 2-way Amplifiers Caused by Insufficient Isolation of Built in Diplex Filter

2.3 ANSI/SCTE 109 2005: Test Procedure for Common Path Distortion

Each of the above procedures targets a different measurement for a unique purpose. They are independent, are specifically applicable to the device being measured, use the test equipment commonly available at the manufacturing sites used to make the device being tested, and directly measure the impairment that must be controlled. The key differences are whether they are designed for actives or passives and whether they are single port or two port measurements. Other differences are the types of distortion products being measured and the filters required to do so.

2.4 ANSI/SCTE 144 2007: Test Procedure for Measuring Transmission and Reflection

3.0 EQUIPMENT

3.1 Carrier generator

The device is used to generate a continuous wave (CW) carrier in the range of 5– 42 MHz. at up to a 60 dBmV signal level.

3.2 Spectrum analyzer

The device needs to be able to measure from 10 – 84 MHz. (One of the following or equivalent.)

- Hewlett Packard E4411B
- Tektronix U3641/N

3.3 Diplexers

Diplexer (D1)

- Separates the carrier frequency from the second harmonic frequency. The diplexer low pass filter passes the carrier frequency under test.
- The upper band edge of the diplexer low pass filter is to be above the carrier frequency and below the carrier second harmonic frequency.
- The diplexer low pass filter insertion loss at the second harmonic frequency is to be large enough so that when the filter is connected to the generator, the second harmonic signal level is at least 120 dB lower than the carrier.

Diplexer (D2)

- The diplexer high pass filter passes the carrier second harmonic.
- The lower band edge of the diplexer high pass filter is to be above the carrier frequency and below the carrier second harmonic frequency.
- The diplexer high pass filter reduces the carrier signal by at least 30 dB. (The filter is used to prevent the carrier from over driving the spectrum analyzer and creating second harmonics in the analyzer.)

Alternatively, if the user does not have all the required diplex filters for the test, then a low pass filter with the characteristics described for the low pass filter in Diplexer (D1) can be used in instead of Diplexer (D1). However, Diplexer (D2) still needs to be a diplex filter in order to properly terminate the DUT.

3.4 75 Ohm Terminators

Used to dissipate unwanted signals.

3.5 Attenuators

Attenuator A1

- Used to reduce signal strength into the spectrum analyzer

Attenuator A2

- Approximate the insertion loss of the device under test
- Provide a 75 Ohm impedance load to the diplex filters

4.0 SET-UP

4.1 Follow all calibration requirements recommended by the manufacturers for the carrier generator, and spectrum analyzer.

4.2 The diplexers in this document will be referred to as diplexer (D1) and diplexer (D2) as shown in Figure 1.

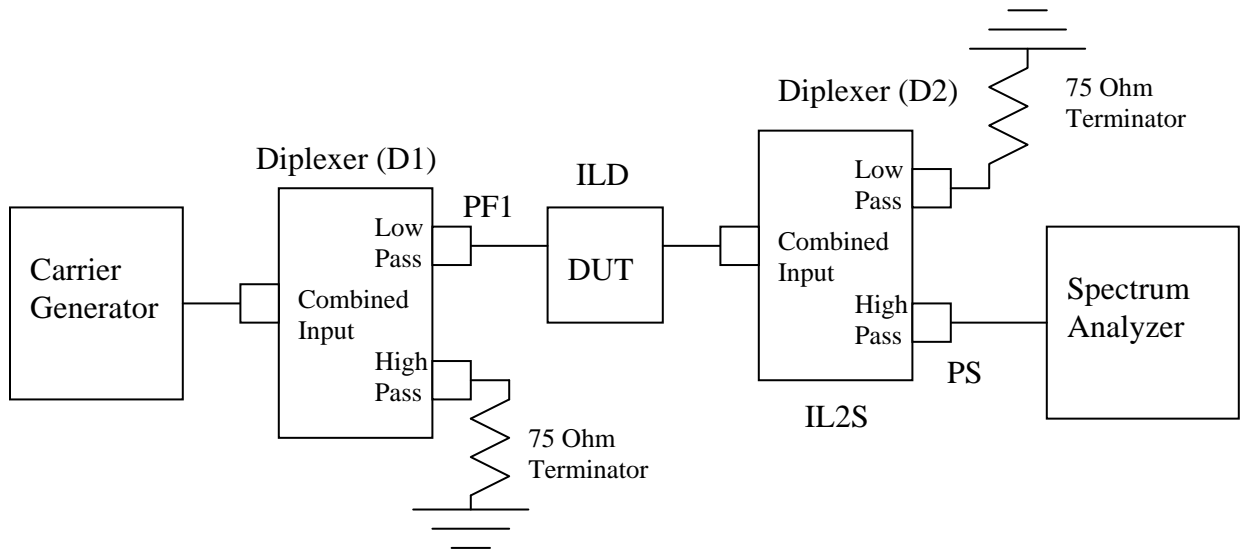

Figure 1: Second harmonic distortion test set-up

4.3 Measure and record the insertion loss for the following devices:

Device under test (DUT)

- Measure the insertion loss at the carrier frequency of interest and at the second harmonic frequency.
- Record the insertion loss at the frequency of interest as ILD
- Record the insertion loss at the second harmonic frequency as ILDS.

Diplexer (D2)

- Measure the insertion loss at twice the carrier frequency of interest from the combined input to the high pass output. During the insertion loss test a 75 Ohm terminator should be connected to the diplexer (D2) low pass output port.
- Record the Diplexer (D2) insertion loss value as IL2S.

Attenuator (A1)

- Measure the insertion loss at the carrier frequency of interest
- Record the Attenuator (A1) insertion loss value as ILA1.

Attenuator (A2)

- Measure the insertion loss at the carrier frequency of interest and at the second harmonic frequency.
- Record the insertion loss at the frequency of interest as ILA2
- Record the insertion loss at the second harmonic frequency as ILA2S
- Confirm the insertion loss of attenuator (A2) at the carrier and second harmonic frequencies is similar to the DUT insertion loss to within 0.5 dB.

The insertion loss for the above items can be measured using either SCTE 144 2007 or a signal generator and spectrum analyzer. Loss shall be recorded as a positive value.

5 PROCEDURE

- 5.1 Connect the carrier generator output to the diplexer (D1) combined input.
- 5.2 Connect the diplexer (D1) high pass output to a 75 Ohm terminator.
- 5.3 Set the spectrum analyzer settings as follows

Center Frequency	The carrier frequency under test
Span	3 MHz.
Detector	Peak
Resolution Bandwidth	30 kHz.
Video Bandwidth	30 Hz.

- 5.4 Place attenuator (A1) on the diplexer (D1) low pass output. (The attenuator must be large enough to prevent the carrier signal from over driving the spectrum analyzer.)
- 5.5 Attach the spectrum analyzer to the other end of the attenuator. See figure 2.

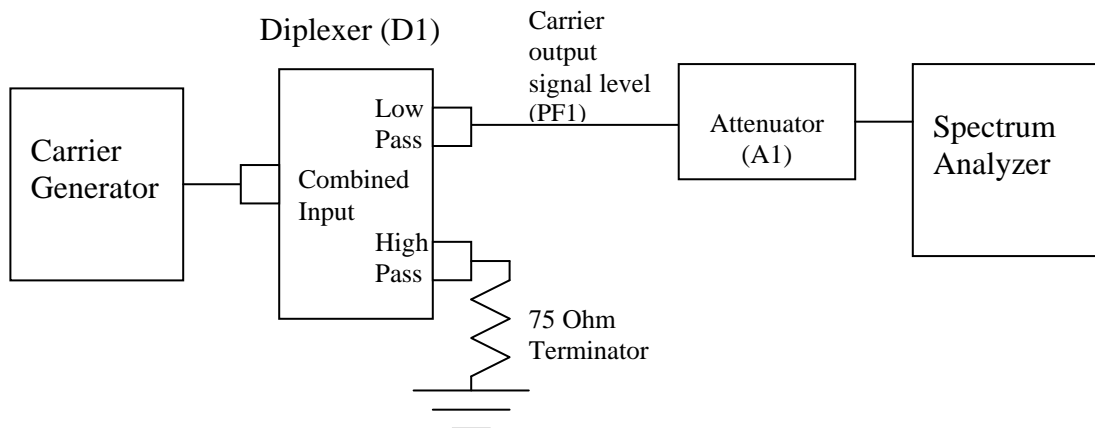

Figure 2: Test set-up to set and verify carrier signal level

- 5.6 Set the carrier generator to the frequency of interest (5 - 42 MHz.) and confirm the signal frequency is correct on the spectrum analyzer.

Record the carrier frequency in MHz.

- 5.7 PF1 is the signal level of the carrier coming from the diplexer (D1) low pass filter output. PA is the signal level of the carrier output to the spectrum analyzer

Using $PF1 = PA + ILA1$, set the carrier generator for the specified signal level for the signal PF1.

Record PF1 in dBmV.

- 5.8 Disconnect the spectrum analyzer and attenuator from the diplexer (D1).
- 5.9 Connect the diplexer (D2) combined input to the diplexer (D1) low pass output through a attenuator (A2).
- 5.10 Connect a 75 Ohm terminator to the diplexer (D2) low pass output port.
- 5.11 Set the spectrum analyzer center frequency to twice the carrier frequency.
- 5.12 Connect the spectrum analyzer to the diplexer (D2) high pass output and measure the carrier second harmonic output signal level (PS2) in dBmV. See figure 3.

The actual carrier second harmonic output signal level of interest (PS1) is the second harmonic output from the diplexer (D1) low pass output port.

Using $PS1 = PF1 - (PS2 + ILA2 + IL2S)$, calculate the second harmonic distortion in the test setup relative to the fundamental carrier. Note that this is a positive

number, expressed in -dBc. Refer to the Definitions and Acronyms section of ANSI/SCTE 96 2003 for a discussion of these units.

Verify that the second harmonic distortion, PS1 (expressed as a positive number), is at least 10 dB more than the second order distortion specification for which the user is testing.

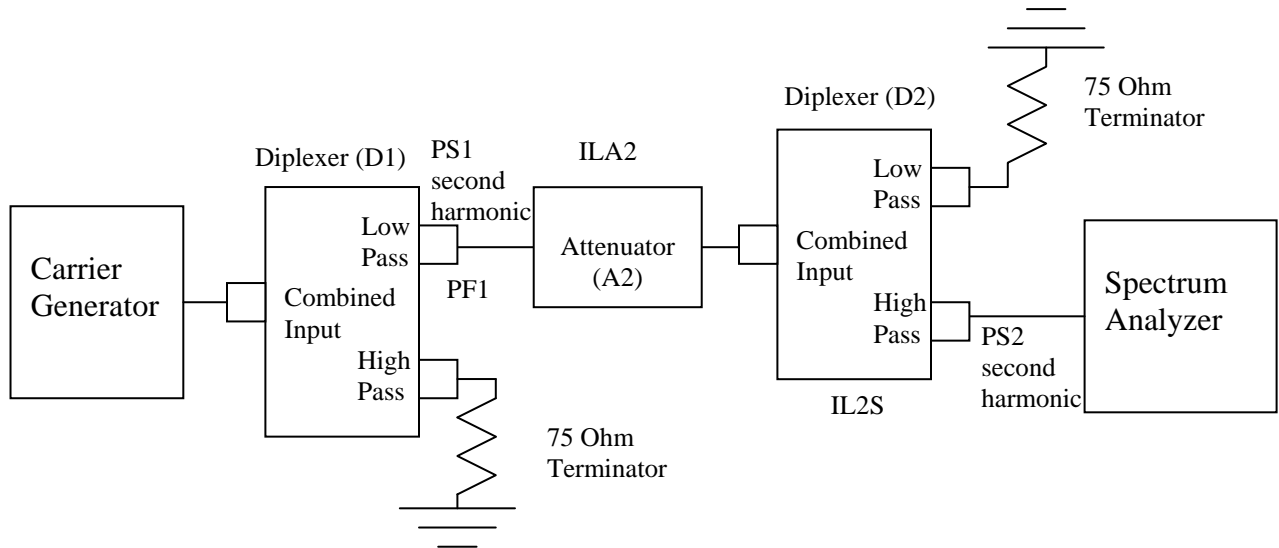

Figure 3: Test set-up to measure level of second harmonic distortion present without the device under test (DUT).

- 5.13 Disconnect attenuator A2 and diplexer (D2) from diplexer (D1).
- 5.14 Connect the device under test (DUT) between diplexer (D1) and diplexer (D2) as shown in Figure 1.
- 5.15 Measure the carrier second harmonic signal level out of diplexer (D2) and record the signal level as PS.
- 5.16 Second harmonic distortion (SHD) for the DUT is $SHD = (PF1 - ILD) - (PS + IL2S)$. Calculate and record the DUT second harmonic distortion test results. Note that this is a positive number, expressed in -dBc. Refer to the Definitions and Acronyms section of ANSI/SCTE 96 2003 for a discussion of these units.

6 REPORT FORM

Device Under Test (DUT)			
DUT Sample Number			
Test Date			
Carrier frequency			
Fundamental carrier power input into the DUT	PF1		dBmV
Device Under Test Insertion Loss at carrier frequency	ILD		dB
Device Under Test Insertion Loss at the second harmonic frequency	ILDS		dB
Attenuator (A1) Insertion Loss at carrier frequency	ILA1		dB
Attenuator (A2) Insertion Loss at carrier frequency	ILA2		dB
Attenuator (A2) Insertion Loss at second harmonic frequency	ILA2S		dB
Diplexer (D2) Insertion Loss at second harmonic frequency	IL2S		dB
Second harmonic signal level output from Diplexer (D1) low pass filter port	PS1		dBmV
Second harmonic signal level output from Diplexer (D2) high pass filter port without DUT in test system	PS2		dBmV
Second harmonic signal level output from Diplexer (D2) high pass filter port DUT in test system	PS		dBmV
Second Harmonic Distortion (SHD) (-dBc)			Pass /Fail