



***Society of Cable
Telecommunications
Engineers***

**ENGINEERING COMMITTEE
Data Standards Subcommittee**

AMERICAN NATIONAL STANDARD

ANSI/SCTE 135-5 2009

**DOCSIS 3.0 Part 5: Cable Modem to Customer Premise
Equipment Interface**

NOTICE

The Society of Cable Telecommunications Engineers (SCTE) Standards are intended to serve the public interest by providing specifications, test methods and procedures that promote uniformity of product, interchangeability and ultimately the long term reliability of broadband communications facilities. These documents shall not in any way preclude any member or non-member of SCTE from manufacturing or selling products not conforming to such documents, nor shall the existence of such standards preclude their voluntary use by those other than SCTE members, whether used domestically or internationally.

SCTE assumes no obligations or liability whatsoever to any party who may adopt the Standards. Such adopting party assumes all risks associated with adoption of these Standards, and accepts full responsibility for any damage and/or claims arising from the adoption of such Standards.

Attention is called to the possibility that implementation of this standard may require the use of subject matter covered by patent rights. By publication of this standard, no position is taken with respect to the existence or validity of any patent rights in connection therewith. SCTE shall not be responsible for identifying patents for which a license may be required or for conducting inquiries into the legal validity or scope of those patents that are brought to its attention.

Patent holders who believe that they hold patents which are essential to the implementation of this standard have been requested to provide information about those patents and any related licensing terms and conditions. Any such declarations made before or after publication of this document are available on the SCTE web site at <http://www.scte.org>.

All Rights Reserved

© Society of Cable Telecommunications Engineers, Inc. 2009
140 Philips Road
Exton, PA 19341

Note: DOCSIS® is a registered trademark of Cable Television Laboratories, Inc., and is used in this document with permission.

Table of Contents

1	SCOPE	1
1.1	INTRODUCTION AND PURPOSE.....	1
1.2	REQUIREMENTS.....	1
2	REFERENCES	2
2.1	NORMATIVE REFERENCES.....	2
2.2	REFERENCE ACQUISITION.....	2
3	TERMS AND DEFINITIONS	3
4	ABBREVIATIONS AND ACRONYMS	3
5	OVERVIEW	4
5.1	SERVICE GOALS.....	4
5.2	REFERENCE ARCHITECTURE.....	4
6	NORMATIVE REQUIREMENTS	6
6.1	LIST OF CM INTERFACES.....	6
6.2	EXTERNAL CPE INTERFACES.....	6
6.2.1	<i>Ethernet</i>	6
6.2.2	<i>Universal Serial Bus (USB)</i>	7

List of Figures

FIGURE 5-1	TRANSPARENT IP TRAFFIC THROUGH THE DATA-OVER-CABLE SYSTEM.....	4
FIGURE 5-2	DATA-OVER-CABLE REFERENCE ARCHITECTURE.....	5
FIGURE 6-1	CM ETHERNET PROTOCOL STACK.....	7
FIGURE 6-2	END-TO-END USB CABLE MODEM PROTOCOL STACK.....	9

This page left blank intentionally.

1 SCOPE

1.1 Introduction and Purpose

This interface specification is one of a family of interface specifications designed to facilitate the implementation of data services over Hybrid Fiber-Coax (HFC) cable networks, as well as over coaxial-only cable networks. Figure 5-1 provides the context for this specification in relation to the data-over-cable reference architecture and the other interface specifications in the family. This specification defines the interface requirements for data-over-cable services between a cable modem and the customer premise equipment (CPE). The CPE may include PCs, Macintoshes, workstations, network computers, and other electronic equipment. This specification defines the applicable communications standards and protocols as needed to implement a cable modem interface to the CPE.

This specification only applies to DOCSIS 3.0 (and forward) cable systems employing HFC (Hybrid Fiber Coax) and coaxial architectures. This document:

- describes the communications protocols and standards to be employed,
- specifies the data communication requirements and parameters that will be common to all units,
- describes any additional application-unique interface requirements to ensure support for data-over-cable services.

This document specifies open protocols, with a preference for existing, well-known and well-accepted standards. This interface specification is written to provide the minimal set of requirements for satisfactory communication between the cable modem and CPE.

“Cable Modem to Customer Premise Equipment Interface” (CMCI) is the general term used to describe this interface.

1.2 Requirements

Throughout this document, the words that are used to define the significance of particular requirements are capitalized. These words are:

- | | |
|--------------|---|
| “MUST” | This word means that the item is an absolute requirement of this specification. |
| “MUST NOT” | This phrase means that the item is an absolute prohibition of this specification. |
| “SHOULD” | This word means that there may exist valid reasons in particular circumstances to ignore this item, but the full implications should be understood and the case carefully weighed before choosing a different course. |
| “SHOULD NOT” | This phrase means that there may exist valid reasons in particular circumstances when the listed behavior is acceptable or even useful, but the full implications should be understood and the case carefully weighed before implementing any behavior described with this label. |
| “MAY” | This word means that this item is truly optional. One vendor may choose to include the item because a particular marketplace requires it or because it enhances the product, for example; another vendor may omit the same item. |

2 REFERENCES

2.1 Normative References

The following documents contain provisions, which, through reference in this text, constitute provisions of this standard. At the time of publication, the editions indicated were valid. All standards are subject to revision, and parties to agreement based on this standard are encouraged to investigate the possibility of applying the most recent editions of the documents listed below.

- [ISO/IEC 8802-2] ISO/IEC 8802-2 (ANSI/IEEE Std. 802-2):1998, Information technology-Telecommunications and information exchange between systems-Local and metropolitan area networks-Specific requirements-Part 2: Logical link control.
- [ISO/IEC 8802-3] ISO/IEC 8802-3 (ANSI/IEEE Std. 802.3): 2005, Information technology-Local and metropolitan area networks-Part 3: Carrier sense multiple access with collision detection (CSMA/CD) Access Method and Physical Layer Specifications.
- [ISO/IEC 10038] ISO/IEC 10038 (ANSI/IEEE 802.1D): 2004, Information technology-Telecommunications and information exchange between systems-Local area networks-Media access control (MAC) bridges.
- [NDC2] Device Class Power Management Reference Specification-Network Device Class, Microsoft, Advanced Micro Devices, V2.0, October 12, 2000.
- [NDIS] Network Driver Interface Specification (NDIS) version 6.0, Microsoft Corporation.
- [SCTE 135-4] ANSI/SCTE 135-4 2008, DOCSIS 3.0 Part 4: Operations Support Systems Interface
- [SCTE 135-2] ANSI/SCTE 135-2 2008, DOCSIS 3.0 Part 2: MAC and Upper Layer Protocols
- [USB2] Universal Serial Bus Specification, Compaq, Hewlett Packard, Intel, Lucent, Philips, Revision 2.0, April 27, 2000.
- [USB_DEF] Universal Serial Bus Class Definitions for Communication Devices, Revision 1.1, January 19, 1999.
- [USB_EEM] Universal Serial Bus Communications Class Subclass Specification for Ethernet Emulation Model Devices, Revision 1.0, February 2, 2005.

2.2 Reference Acquisition

- Institute of Electrical and Electronic Engineers (IEEE): <http://www.ieee.org>.
- International Organization for Standardization (ISO): <http://www.iso.org>.
- Microsoft Corporation: <http://www.microsoft.com/whdc/resources/respec/specs/pmref/download.mspx>.
- Society of Cable Telecommunications Engineers (SCTE): <http://www.scte.org>.
- USB Implementers Forum: <http://www.usb.org>.

3 TERMS AND DEFINITIONS

This specification uses the following terms:

Ethernet Interface A Local-Area-Network interface standardized in [ISO/IEC 8802-2].

4 ABBREVIATIONS AND ACRONYMS

This specification uses the following abbreviations:

ARP	Address Resolution Protocol
CM	Cable Modem
CMCI	Cable Modem to CPE Interface
CMTS	Cable Modem Termination System
CPE	Customer Premise Equipment
DHCP	Dynamic Host Configuration Protocol
DCE	Data Communications Equipment
DTE	Data Terminal Equipment
HFC	Hybrid Fiber Coax
ICMP	Internet Control Message Protocol
IP	Internet Protocol
LLC	Logical Link Control
MAC	Media Access Control
SNAP	Sub Network Access Protocol
SNMP	Simple Network Management Protocol, defined in [ISO/IEC 8802-2].
USB	Universal Serial Bus

5 OVERVIEW

This document defines cable-modem-to-customer-premise-equipment interface (CMCI) specifications for high-speed data-over-cable systems. These specifications were developed, for the benefit of the cable industry via deployment of data-over-cable systems on a uniform, consistent, open, non-proprietary, and multi-vendor interoperable basis.

5.1 Service Goals

The intended service will allow bi-directional transfer of data between the cable system headend and customer locations, over an all-coaxial or hybrid fiber-coax (HFC) cable network. This is shown in simplified form in Figure 5-1.

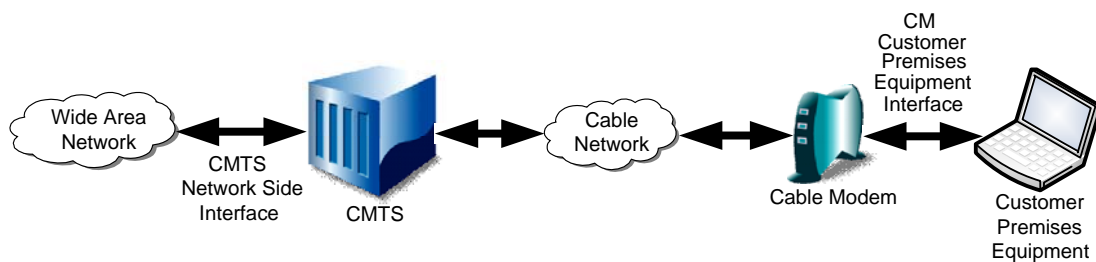

Figure 5-1 Transparent IP Traffic Through the Data-Over-Cable System

The transmission path over the cable system is realized at the headend by a Cable Modem Termination System (CMTS), and at each customer location by a Cable Modem (CM). At the headend (or hub), the interface to the data-over-cable system is called the Cable Modem Termination System - Network-Side Interface (CMTS-NSI). At the customer locations, the interface is called the cable-modem-to-customer-premises-equipment interface (CMCI) and is specified in this document.

The intent is for the DOCSIS operators to transfer data between the Cable Modem Termination System—Network Side Interface (CMTS-NSI) and the CMCI Interface, including but not limited to datagrams, DHCP (Dynamic Host Configuration Protocol), ICMP (Internet Control Message Protocol), and IP (Internet Protocol) Group addressing (broadcast and multicast).

5.2 Reference Architecture

The reference architecture for the data-over-cable services and interfaces is shown in Figure 5-2.

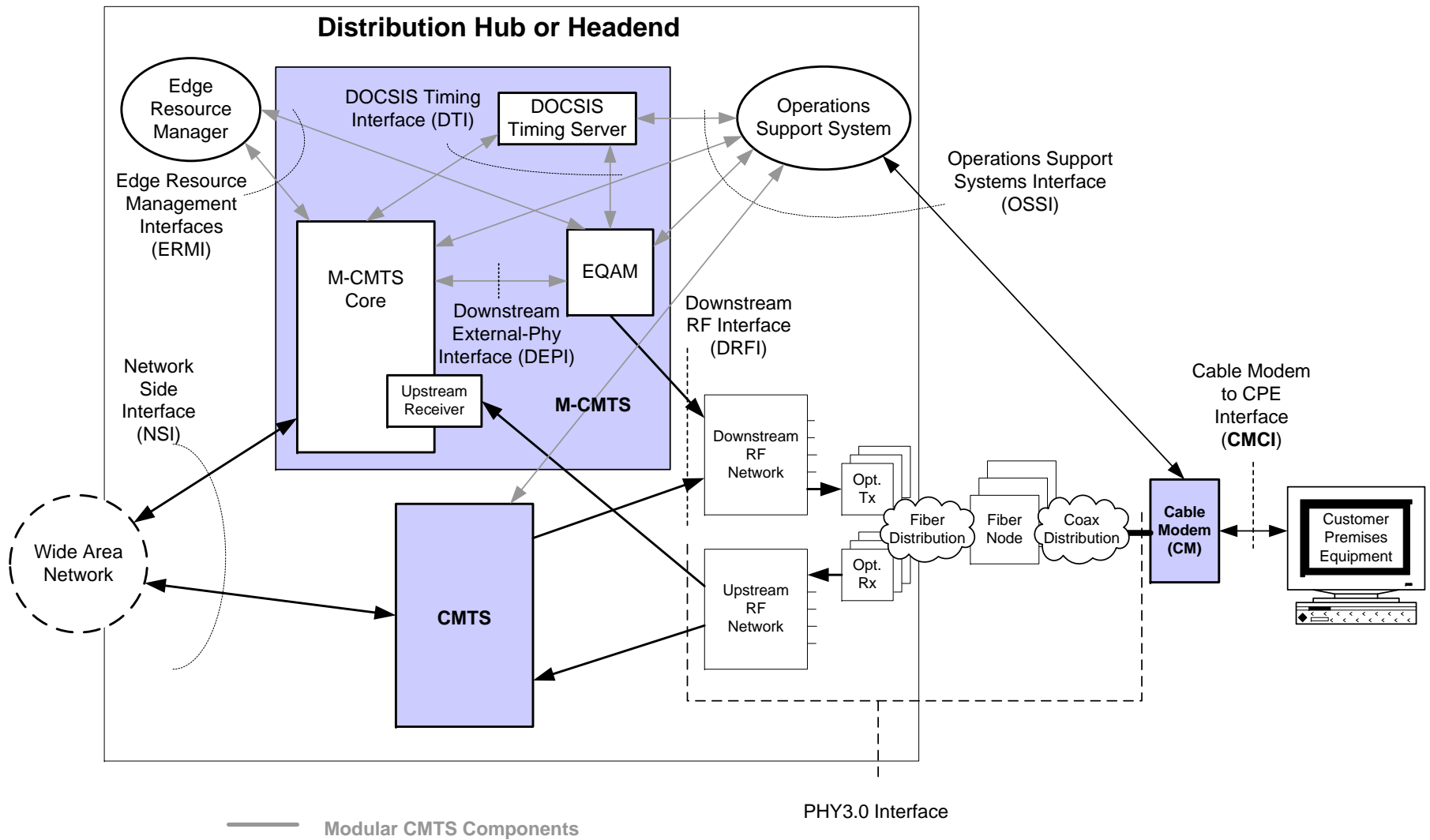

Figure 5-2 Data-Over-Cable Reference Architecture

6 NORMATIVE REQUIREMENTS

6.1 List of CM Interfaces

There are many types of interfaces that may be on a cable modem, such as:

- The Radio Frequency Interface (RFI), described in [SCTE 135-2].
- The Cable Modem to Customer Premise Equipment Interface (CMCI), described in this specification.
- Hardware test interfaces, such as JTAG and other proprietary approaches, are part of the silicon and do not always have software controls to turn the interfaces off. These interfaces are hardware state machines that sit passively until their input lines are clocked with data. Though these interfaces can be used to read and write data, they require an intimate knowledge of the chips and the board layout and are therefore difficult to attack. Hardware test interfaces MAY be present in a CM. A CM MUST NOT have hardware test interfaces that are labeled or documented for customer use.
- Management access interfaces, also called console ports, are communication paths (usually RS-232, but may be Ethernet or other interfaces) and debug software that interact with a user. The software prompts the user for input and accepts commands to read and write data to the CM. If the software for this interface is disabled, the physical communications path is disabled. A CM MUST NOT allow access to CM functions via a management access interface. (DOCSIS CM functions are defined by the DOCSIS specifications and are essentially layer 1/layer 2 functions.) Access to CM functions MUST only be allowed via interfaces specifically prescribed by the DOCSIS specifications, such as the RF interface and operator-controlled SNMP (Simple Network Management Protocol) access via the CMCI (see [SCTE 135-4] for more information).
- Read-only diagnostic interfaces can be implemented many ways and are used to provide useful debugging, trouble-shooting, and CM status information to users. A CM MAY have read-only diagnostic interfaces.
- Some products may choose to implement higher-layer functions (such as customer-premise data network functions) that may require configuration by a user. A CM MAY provide the ability to configure non-DOCSIS functions. Management interface (read/write) access to CM functions MUST NOT be allowed through the mechanism used for configuring non-DOCSIS functions.

6.2 External CPE Interfaces

This document does not mandate any specific number or type of CM interface.

6.2.1 Ethernet

If the Cable Modem supports an “Ethernet Interface” ([ISO/IEC 8802-2] and [ISO/IEC 8802-3]), the following subsections apply. A Cable Modem supporting an Ethernet Interface has the structure shown in Figure 6-1.

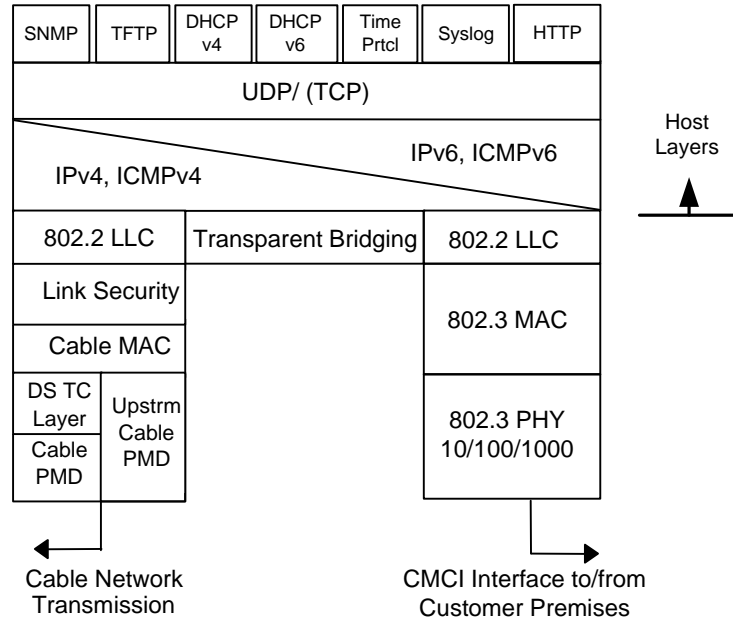

Figure 6-1 CM Ethernet Protocol Stack

6.2.1.1 Data Link Layer

The Ethernet CMCI MUST be compatible with [ISO/IEC 8802-2] and [ISO/IEC 8802-3] with:

- Logical Link Controller (LLC) Sublayer in accordance with [ISO/IEC 8802-2] including Class 1, Type 1 LLC/SNAP (Sub Network Access Protocol),
- Support for both the type and length interpretations of the Type/Length field of [ISO/IEC 8802-3],
- Support for half and full duplex mode with auto-negotiation as outlined by [ISO/IEC 8802-3] Clause 28,
- Medium Access Control (MAC) Sublayer in accordance with [ISO/IEC 8802-3],
- A 48-bit address as required by [ISO/IEC 8802-2] and [ISO/IEC 8802-3].

The Spanning Tree Algorithm and Protocol [ISO/IEC 10038] is allowed but not required (see [SCTE 135-2]).

6.2.1.2 Physical (PHY) Layer

The physical layer interface MUST be in accordance with [ISO/IEC 8802-3], employing an RJ-45 connector and with DTE/DCE (Data Terminal/Data Communication Equipment) auto sensing.

The Ethernet CMCI physical layer interface speed MUST conform to at least one of:

- 10BASE-T [ISO/IEC 8802-3] clause 14,
- 100BASE-TX [ISO/IEC 8802-3] clause 25,
- 1000BASE-T [ISO/IEC 8802-3] clause 40.

If a range of interface speeds is supported, the Ethernet CMCI MUST support interface speed auto-negotiation.

6.2.2 Universal Serial Bus (USB)

The following subsections apply if the Cable Modem supports a USB Interface.

6.2.2.1 Overview and goals

The Universal Serial Bus (USB) is a peripheral interconnect bus that is provided by many Customer Premises Equipment (CPE) devices, particularly personal computers manufactured after December, 1996. It delivers the following attributes of particular interest for cable modem peripheral equipment:

- An external CPE interface, where an end-user can easily plug in new peripherals without needing any special tools or skills.
- Automatic device identification, configuration and mapping of device function to its software, further simplifying the installation process (“Plug and Play”).
- Transfer rates between the peripheral and the CPE up to many Mbits/sec.

USB creates the appearance of a private, point-to-point connection between its host (CPE) and devices attached to it over the USB. Unlike an Ethernet-attached cable modem, a USB-attached cable modem is, by definition, a single-user device connected to only one CPE. The result is that the cable modem conceptually resembles a simple Ethernet NIC that has been installed into a single CPE, and some complex functions (e.g., [ISO/IEC 10038] 802.1d bridging) are, therefore, not required in a USB cable modem.

The specific details of how the USB is used and the format of messages between the CPE and the USB-attached cable modem are not specified in this document, where only functional requirements between the host CPE and the USB are defined. Instead, there are industry-approved specifications [USB_DEF], which include definitions for USB networking devices.

From [USB_DEF], all USB-attached DOCSIS cable modems MUST be compliant with the *Ethernet Networking Control Model*, the *Abstract Control Model* as defined in the USB Communication Device Class, or the *Ethernet Emulation Model* [USB_EEM]. If the *Abstract Control Model* is used:

- The CM MUST exchange Ethernet frames over the Data Class interface.
- The CM MUST implement a Remote [NDIS] driver.

A vendor’s cable modem and associated CPE software is intended to appear no different than an Ethernet-attached cable modem when viewed from its RF interface.

6.2.2.2 Signaling Stack Summary for USB CMCI

Ethernet [ISO/IEC 8802-3] MAC-layer frames MUST be passed transparently through the CMCI. Figure 6-2 shows the USB Cable Modem Stack in the context of the End-to-End Protocol Stack.

6.2.2.3 End-to-end USB Cable Modem protocol stack

Figure 6-2 shows an end-to-end protocol stack (from CMTS to CPE), where a typical USB-attached cable modem is involved. It should be used for additional perspective when reading descriptions of the USB CMCI signaling stack layers that follow. The USB cable modem, as shown in Figure 6-2, MUST have two 48-bit MAC (Media Access Control) addresses. The first 48-bit MAC address (herein referred to as the “Host CPE MAC address”) MUST be associated with forwarding frames to the host CPE through the 802.3 Filter, where the host CPE perceives this MAC address as if this portion of the cable modem were a simple Ethernet NIC installed in the host. This is analogous to the classic Ethernet CMCI (see Figure 6-1), where this MAC address is in fact in a CPE Ethernet NIC card. The second 48-bit MAC address MUST be associated with the cable modem being an IP / LLC host for cable modem management functions.

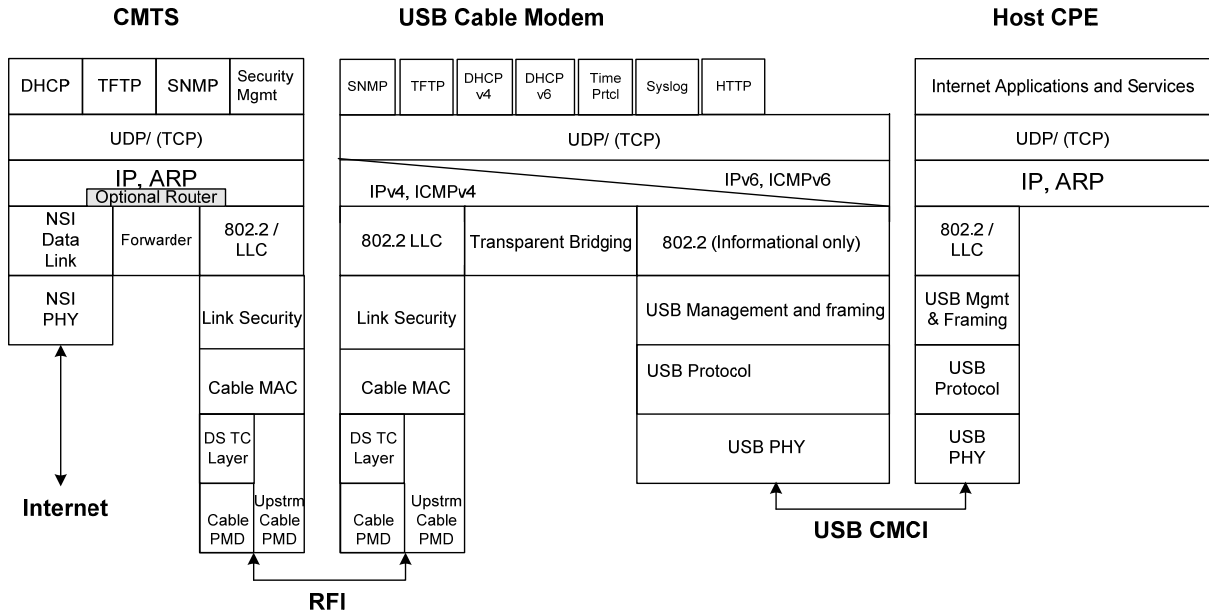

Figure 6-2 End-to-End USB Cable Modem Protocol Stack

6.2.2.4 Data Link Layer

The sublayers within the USB CMCI data link layer are defined in the following subsections.

6.2.2.4.1 802.2 Logical Link Controller (LLC) Sublayer

The LLC sublayer interface MUST be in accordance with [ISO/IEC 8802-2] including Class 1, Type 1 LLC/SNAP. Note that the CM MUST NOT respond to [ISO/IEC 8802-2] LLC host requests (TEST and XID) addressed to its Host CPE MAC address, since this is the responsibility of the host CPE. The CM MUST pass these frames transparently to the host CPE without responding to them on its own.

6.2.2.4.2 802.3 Filtering

The notion of bridging is limited for a USB-attached cable modem, since the connection to a CPE is point-to-point and private. There is no other equipment on the USB for which the cable modem performs bridging, so this layer is reduced to simple forwarding rules that resemble the behavior of a typical Ethernet NIC, as follows.

Cable-Network-to-CPE forwarding MUST follow these specific rules:

- Frames addressed to the cable modem’s Host CPE MAC address MUST be forwarded over USB to the CPE.
- Broadcast frames MUST be forwarded over the USB to the CPE.
- Multicast frames MUST be forwarded over the USB to the CPE, in accordance with filtering configuration settings specified by the cable operator’s operations and business support systems, with one recommended exception: the host CPE SHOULD additionally be able to configure the attached cable modem (by some vendor-specific device management messages) to do further restrictive filtering (beyond the MSO-configured filters) to prevent the forwarding of multicast frames that the host CPE software has not indicated an interest in receiving. The host CPE MUST NOT be able to either access or alter MSO-configured filters.
- Defined mechanisms exist for CPE networking devices (e.g., Ethernet NICs) to support a “sleep” mode where additional filtering is accomplished using programmable pattern filters as specified by the CPE networking stack. When a programmed pattern is detected, this causes the CPE to wake up to service the incoming

connection. A cable modem SHOULD support such a wake-up function, with the ability to perform USB resume signaling to the CPE in accordance with [USB2], [USB_DEF], and [NDC2].

- Ethernet frames with the cable modem's Ethernet MAC address MUST NOT be forwarded by the cable modem to the host CPE.

CPE to Cable Network forwarding MUST follow these specific rules:

- Since a USB-attached cable modem has a virtual private connection to the host CPE, everything received from the CPE over USB that has been designated as an outbound data PDU frame MUST be forwarded to the cable network in accordance with filters set in the modem.

Unlike a simple Ethernet NIC, the USB-attached cable modem MUST NOT operate in a promiscuous mode where all frames are forwarded over the USB, since the aggregate of downstream frames for all MAC addresses would exceed the bandwidth capacity of the USB. This requirement implies that the attached CPE itself must not function as a bridge.

6.2.2.4.3 802.3 Medium Access Control (MAC) Sublayer

The MAC sublayer interface MUST be in accordance with [ISO/IEC 8802-3].

6.2.2.4.4 Ethernet

The data-link layer interface MUST be in accordance with [ISO/IEC 8802-2] and [ISO/IEC 8802-3].

6.2.2.4.5 Address Length

A 48-bit address MUST be utilized for [ISO/IEC 8802-3].

6.2.2.4.6 USB Management and Framing Sublayer

This vendor-defined layer is specific to a particular cable modem implementation. Its purpose is to adapt [ISO/IEC 8802-3] MAC frames and device management into a format that can be exchanged over the USB. It provides two primary functions:

1. Framing: Since the underlying USB protocol provides a streaming pipe interface to its clients, this sublayer MUST be implemented in both the CPE and cable modem to provide the necessary synchronization, [ISO/IEC 8802-3]/ frame delineation, and stream error handling functions. This may involve the usage of additional headers.
2. Device management: Management message interfaces MUST be provided that enable the host CPE to query and configure the cable modem to work properly with the CPE and its networking stack.

As mentioned in the overview (see Section 6.2.2.1), it is beyond the scope of this specification to describe either the USB transfer types used, or detailed frame formats. A USB-attached cable modem conceptually resembles an installed Ethernet NIC from the CPE's point of view. To support that model, some level of device management capability is required for the CPE and its networking stack to operate properly as described below:

- The TCP/IP stack residing in the host CPE needs to be able to discover the 48-bit host CPE MAC address of the USB cable modem to allow the CPE to respond correctly to frames from the CMTS, e.g., an ARP (Address Resolution Protocol) request. Since there is no Ethernet NIC used with USB, a USB modem MUST implement a MAC address for frames destined to the host CPE.
- Similar to the way host CPE networking stacks are able to negotiate with Ethernet NICs, the host CPE should be able to negotiate with the cable modem to specify pattern filters to be used to wake-up the CPE when it is in a power-managed "sleep" state. See [NDC2], [USB2], and [USB_DEF] for further details on network device pattern filtering and CPE wake-up signaling for USB.

6.2.2.4.7 *USB Protocol Sublayer*

The USB protocol sublayer contains the link protocol used for various types of transactions over USB, and is usually implemented by a low-level USB controller. The CM USB protocol sublayer **MUST** be in accordance with the USB protocol as described in [USB2].

6.2.2.5 *Physical (PHY) Layer*

The physical layer interface **MUST** be in accordance with [USB2] and [USB_DEF]. The USB CMCI physical layer **MUST** be compatible with [USB2] and [USB_DEF], and include a Series A or Series B USB receptacle.
