

SCTE | **STANDARDS**

Interface Practices Subcommittee

AMERICAN NATIONAL STANDARD

ANSI/SCTE 10 2014 (R2021)

Test Method for Flexible Coaxial Cable Impact

NOTICE

The Society of Cable Telecommunications Engineers (SCTE) Standards and Operational Practices (hereafter called “documents”) are intended to serve the public interest by providing specifications, test methods and procedures that promote uniformity of product, interoperability, interchangeability, best practices, and the long term reliability of broadband communications facilities. These documents shall not in any way preclude any member or non-member of SCTE from manufacturing or selling products not conforming to such documents, nor shall the existence of such standards preclude their voluntary use by those other than SCTE members.

SCTE assumes no obligations or liability whatsoever to any party who may adopt the documents. Such adopting party assumes all risks associated with adoption of these documents and accepts full responsibility for any damage and/or claims arising from the adoption of such documents.

NOTE: The user’s attention is called to the possibility that compliance with this document may require the use of an invention covered by patent rights. By publication of this document, no position is taken with respect to the validity of any such claim(s) or of any patent rights in connection therewith. If a patent holder has filed a statement of willingness to grant a license under these rights on reasonable and nondiscriminatory terms and conditions to applicants desiring to obtain such a license, then details may be obtained from the standards developer. SCTE shall not be responsible for identifying patents for which a license may be required or for conducting inquiries into the legal validity or scope of those patents that are brought to its attention.

Patent holders who believe that they hold patents which are essential to the implementation of this document have been requested to provide information about those patents and any related licensing terms and conditions. Any such declarations made before or after publication of this document are available on the SCTE web site at <https://scte.org>.

All Rights Reserved
© 2021 Society of Cable Telecommunications Engineers, Inc.
140 Philips Road
Exton, PA 19341

1.0 DOCUMENT TYPES AND TAGS

Document Type: Specification

Document Tags:

- | | | |
|---|------------------------------------|--|
| <input checked="" type="checkbox"/> Test or Measurement | <input type="checkbox"/> Checklist | <input type="checkbox"/> Facility |
| <input type="checkbox"/> Architecture or Framework | <input type="checkbox"/> Metric | <input checked="" type="checkbox"/> Access Network |
| <input type="checkbox"/> Procedure, Process or Method | <input type="checkbox"/> Cloud | <input type="checkbox"/> Customer Premises |

2.0 DOCUMENT RELEASE HISTORY

Release	Date
SCTE 10 2001	5/30/2001
SCTE 10 2008	7/11/2008
SCTE 10 2014	6/6/2014

Note: This document is a reaffirmation of SCTE 10 2014. No substantive changes have been made to this document. Information components may have been updated such as the title page, NOTICE text, headers, and footers.

TABLE OF CONTENTS

1.0	DOCUMENT TYPES AND TAGS.....	II
2.0	DOCUMENT RELEASE HISTORY	II
3.0	SCOPE	2
4.0	NORMATIVE REFERENCES	2
5.0	COMPLIANCE NOTATION.....	2
6.0	EQUIPMENT	3
7.0	TEST SAMPLES.....	4
8.0	TEST METHOD.....	4
9.0	INSEPCION	4
10.0	TEST RECORD.....	4

LIST OF FIGURES

FIGURE 1 – TEST FIXTURE	3
-------------------------	---

3.0 SCOPE

This test is to establish that specified outdoor flexible RF coaxial drop cable jackets are capable of low temperature characteristics.

4.0 NORMATIVE REFERENCES

The following documents contain provisions, which, through reference in this text, constitute provisions of the standard. At the time of Subcommittee approval, the editions indicated were valid. All standards are subject to revision; and while parties to any agreement based on this standard are encouraged to investigate the possibility of applying the most recent editions of the documents listed below, they are reminded that newer editions of those documents may not be compatible with the referenced version.

4.1 SCTE References

ANSI/SCTE 74 2011, Specification for Braided 75Ω Flexible RF Coaxial Drop Cable

5.0 COMPLIANCE NOTATION

“SHALL”	This word or the adjective “REQUIRED” means that the item is an absolute requirement of this specification.
“SHALL NOT”	This phrase means that the item is an absolute prohibition of this specification.
“SHOULD”	This word or the adjective “RECOMMENDED” means that there may exist valid reasons in particular circumstances to ignore this item, but the full implications should be understood and the case carefully weighted before choosing a different course.
“SHOULD NOT”	This phrase means that there may exist valid reasons in particular circumstances when the listed behavior is acceptable or even useful, but the full implications should be understood and the case carefully weighed before implementing any behavior described with this label.
“MAY”	This word or the adjective “OPTIONAL” means that this item is truly optional. One vendor may choose to include the item because a particular marketplace requires it or because it enhances the product, for example; another vendor may omit the same item.

6.0 EQUIPMENT

- 6.1 Environmental chamber with top port hole – Having the interior chamber size with a vertical dimension of at least four (4) feet (1.22 meters), capable of maintaining temperatures $-15\text{ }^{\circ}\text{C}$ for PVC or $-30\text{ }^{\circ}\text{C} \pm 1\text{ }^{\circ}\text{C}$ degree for PE for a 24 hour period.
- 6.2 Guide Tube – Metallic tube with a smooth inside diameter of approximately 1.25 inches (31.75 mm) \pm 0.125 inches (3.17 mm) and an overall length of 39 inches (991 mm) \pm .50 inches (12.7 mm).
- 6.3 Weight – A cylinder of approximately 1 1/16 inches (2.7 cm) \pm 1/32 inch (.79 mm) in diameter with a weight of one (1) pound (453.6 grams), having a flat striking face with 1/32 inch (.79 mm) beveled edge.
- 6.4 Impact Surface – A flat, smooth carbon steel plate with minimum dimensions of 4 in. x 4 in. x .25 in. thick (10.2 cm x 10.2 cm x 6.35 mm).
- 6.5 See Figure 1 – Test Fixture:

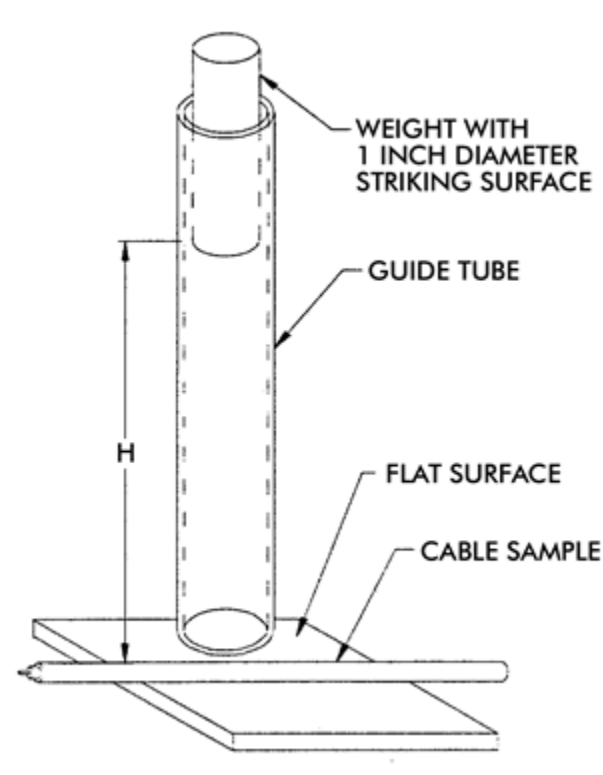

Figure 1 – Test Fixture¹

¹ H=36 inches equating to 3 foot pounds force on the conditioned sample.

7.0 TEST SAMPLES

Five test samples of jacket cables of approximately 15 inches (38 cm) are required.

8.0 TEST METHOD

- 8.1 Place the sample in the Cold Chamber and condition for 4 hours at $-30^{\circ}\text{C} \pm 1\text{ C}$ degree ($-22^{\circ}\text{F} \pm 1.8\text{ F}$ degree) for a polyethylene sample, and $-15^{\circ}\text{C} \pm 1\text{ C}$ degree ($5^{\circ}\text{F} \pm 1.8\text{ F}$ degree) for a PVC sample.
- 8.2 Condition the assembly, the weight and the impact surface in the environmental chamber for a minimum of 4 hours at the specified test temperature.
- 8.3 After the conditioning period, position the drop tube vertically over the impact surface with the test sample resting below on the impact surface.
- 8.4 Secure a test sample across the bottom of the drop tube. Two tests may be conducted on each sample by positioning the weight to strike between center and the end of the CUT.
- 8.5 Release the weight from the top of the tube, impacting the test sample at the bottom.
- 8.6 Test and inspect 10 impact areas.

9.0 INSEPCION

The impact area is to be visually inspected. Failure of testing is a sign of a jacket crack or splits for the 10 impact tests visible to the unaided eye.

10.0 TEST RECORD

Record a pass or fail indication, the size of cable, type of jacket tested and the test temperature used.