

# **SCTE** | **STANDARDS**

---

**Digital Video Subcommittee**

---

**AMERICAN NATIONAL STANDARD**

**ANSI/SCTE 56 2016 (R2021)**

**Digital Multiprogram Distribution by Satellite**

## NOTICE

The Society of Cable Telecommunications Engineers (SCTE) Standards and Operational Practices (hereafter called “documents”) are intended to serve the public interest by providing specifications, test methods and procedures that promote uniformity of product, interoperability, interchangeability, best practices, and the long term reliability of broadband communications facilities. These documents shall not in any way preclude any member or non-member of SCTE from manufacturing or selling products not conforming to such documents, nor shall the existence of such standards preclude their voluntary use by those other than SCTE members.

SCTE assumes no obligations or liability whatsoever to any party who may adopt the documents. Such adopting party assumes all risks associated with adoption of these documents and accepts full responsibility for any damage and/or claims arising from the adoption of such documents.

NOTE: The user’s attention is called to the possibility that compliance with this document may require the use of an invention covered by patent rights. By publication of this document, no position is taken with respect to the validity of any such claim(s) or of any patent rights in connection therewith. If a patent holder has filed a statement of willingness to grant a license under these rights on reasonable and nondiscriminatory terms and conditions to applicants desiring to obtain such a license, then details may be obtained from the standards developer. SCTE shall not be responsible for identifying patents for which a license may be required or for conducting inquiries into the legal validity or scope of those patents that are brought to its attention.

Patent holders who believe that they hold patents which are essential to the implementation of this document have been requested to provide information about those patents and any related licensing terms and conditions. Any such declarations made before or after publication of this document are available on the SCTE web site at <https://scte.org>.

All Rights Reserved  
© 2021 Society of Cable Telecommunications Engineers, Inc.  
140 Philips Road  
Exton, PA 19341

### Document Types and Tags

Document Type: Specification

Document Tags:

- |   |   |  |
|---|---|--|
| <input type="checkbox"/> Test or Measurement                  | <input type="checkbox"/> Checklist        | <input type="checkbox"/> Facility          |
| <input checked="" type="checkbox"/> Architecture or Framework | <input type="checkbox"/> Metric           | <input type="checkbox"/> Access Network    |
| <input type="checkbox"/> Procedure, Process or Method         | <input checked="" type="checkbox"/> Cloud | <input type="checkbox"/> Customer Premises |

### Document Release History

<b>Release</b>	<b>Date</b>
SCTE 56 2004	<i>10/26/2004</i>
SCTE 56 2010	<i>10/8/2010</i>
SCTE 56 2016	<i>5/23/2016</i>

Note: This document is a reaffirmation of SCTE 56 2016. No substantive changes have been made to this document. Information components may have been updated such as the title page, NOTICE text, headers, and footers.

# Digital Multiprogram Distribution by Satellite

## Table of Contents

<b>DOCUMENT TYPES AND TAGS .....</b>	<b>3</b>
<b>DOCUMENT RELEASE HISTORY .....</b>	<b>3</b>
<b>1 INTRODUCTION.....</b>	<b>8</b>
1.1 COMPLIANCE NOTATION.....	8
<b>2 GENERIC REFERENCE MODEL FOR THE COMMON FUNCTIONAL REQUIREMENTS OF A SATELLITE IRD .....</b>	<b>8</b>
<b>3 UNIVERSAL ELEMENTS OF A SATELLITE IRD .....</b>	<b>11</b>
3.1 DEMODULATION AND DECODING .....	11
3.1.1 <i>QPSK demodulator</i> .....	12
3.1.2 <i>Matched filter</i> .....	13
3.1.3 <i>Convolutional decoding</i> .....	13
3.1.4 <i>Sync byte decoder</i> .....	14
3.1.5 <i>Convolutional deinterleaver</i> .....	14
3.1.6 <i>Reed Solomon decoder</i> .....	14
3.1.7 <i>Energy dispersal removal</i> .....	14
3.2 TRANSPORT AND DEMULTIPLEXING .....	15
3.3 SOURCE DECODING OF VIDEO, AUDIO AND DATA.....	15
3.3.1 <i>Video</i> .....	16
3.3.2 <i>Audio</i> .....	16
3.3.3 <i>Data</i> .....	16
<b>4 SUMMARY CHARACTERISTICS OF DIGITAL MULTIPROGRAM TV SYSTEMS BY SATELLITE.....</b>	<b>16</b>
<b>5 SPECIFIC CHARACTERISTICS.....</b>	<b>18</b>
5.1 SIGNAL SPECTRUM OF THE DIFFERENT SYSTEMS AT THE MODULATOR OUTPUT .....	18
5.1.1 <i>Signal spectrum for System I</i> .....	18
5.1.2 <i>Signal spectrum for System II</i> .....	20
5.2 CONVOLUTIONAL CODING.....	26
5.2.1 <i>Convolutional coding characteristics for System I</i> .....	26
5.2.2 <i>Convolutional coding characteristics for System II</i> .....	26
5.3 SYNCHRONIZATION CHARACTERISTICS .....	27
5.3.1 <i>Synchronization characteristics for System I</i> .....	27
5.3.2 <i>Synchronization characteristics for System II</i> .....	27
5.4 CONVOLUTIONAL INTERLEAVER .....	29
5.4.1 <i>Convolutional interleaver for System I</i> .....	29
5.4.2 <i>Convolutional interleaver for System II</i> .....	30

5.5	REED SOLOMON ENCODER .....	31
5.5.1	<i>Reed Solomon encoder characteristics for System I</i> .....	31
5.5.2	<i>Reed Solomon encoder characteristics for System II</i> .....	31
5.6	ENERGY DISPERSAL .....	32
5.6.1	<i>Energy dispersal for System I</i> .....	32
5.6.2	<i>Energy dispersal for System II</i> .....	33
5.7	FRAMING AND TRANSPORT STREAM CHARACTERISTICS.....	35
5.7.1	<i>Framing and Transport stream characteristics for System I</i> .....	35
5.7.2	<i>Framing and Transport stream characteristics for System II</i> .....	35
<b>6.</b>	<b>NORMATIVE REFERENCES .....</b>	<b>36</b>
<b>7.</b>	<b>LIST OF ACRONYMS .....</b>	<b>36</b>

## List of Figures

Figure 1 - Typical IRD protocol stack .....	9
Figure 2 - Generic reference model for a satellite IRD .....	11
Figure 3 – Block diagram for demodulation and channel decoding.....	12
Figure 4 - QPSK constellation .....	13
Figure 5 - Block diagram for transport and demultiplexing .....	15
Figure 6 - Block diagram for source decoding .....	16
Figure 7 - Template for the signal spectrum mask at the modulator output represented in the baseband frequency domain.....	18
Figure 8 - Template Of The Modulator Filter Group Delay.....	19
Figure 9a - Spectral density mask for standard mode.....	21
Figure 9b - Spectral density mask for truncated-spectrum mode .....	22
Figure 10a - Normalized group delay mask for standard mode.....	23
Figure 10b - Normalized group delay mask for truncated-spectrum mode .....	23
Figure 10c - System II spectral mask.....	25
Figure 11 - Convolutional encoder (rate 3/4 example).....	27
Figure 12 - Uplink processing.....	28
Figure 13 - Uplink packet reorder for odd numbered packets .....	29
Figure 14 - Conceptual diagram of the convolutional interleaver and deinterleaver .....	30
Figure 15 - Convolutional interleaver.....	31
Figure 16 - RS code applied to a packet .....	32
Figure 17 - Randomizer/de-randomizer schematic diagram.....	33

Figure 18 - Randomizer block diagram ..... 34  
Figure 19 - Framing structure ..... 35

### List of Tables

Table 1 - Summary characteristics of digital multiprogram TV systems by satellite (Normative)  
..... 17  
Table 2 - Definition of points given in Fig. 7 ..... 19  
Table 3a - Spectral density mask breakpoints for standard mode ..... 20  
Table 3b - Spectral density mask breakpoints for truncated-spectrum mode ..... 21  
Table 4a - Normalized group delay breakpoints for standard mode ..... 24  
Table 4b - Normalized group delay breakpoints for truncated-spectrum mode ..... 24  
Table 4c - System II spectral mask ..... 25  
Table 5 - Punctured code definition ..... 26

This page left blank intentionally

# Digital Multiprogram Distribution by Satellite

## 1 Introduction

**NOTE:** This document is identical to SCTE 56 2011 except for informative components such as the title page, NOTICE text, headers and footers. No changes have been made to any text in the document beyond this point, other than headers and footers.

Satellite Digital TV systems have shown their advantages with respect to the analog TV allowing a more efficient use of the satellite frequency spectrum available and establishing a more robust scenario with respect to interference protection.

With the aim to promote the convergence on a worldwide standard for satellite digital multiprogram reception systems for television, sound and data services, the systems for the reception of Digital Multiprogram Distribution by Satellite are described. These descriptions configure the universal elements of the satellite Integrated Receiver Decoder (IRD).

The universal elements of the satellite IRD are capable of receiving emissions from System I, and System II.

The common and specific elements of each system have been analyzed and it has been concluded on the feasibility of the implementation of the universal elements of a Satellite IRD. This document analyses the common elements among existing systems, defines and describes the functions of a generic system model and identifies the processes and the minimum set of parameters of the various sub-systems of the universal elements of a Satellite IRD.

The feasibility of the implementation of the common elements in a satellite IRD has been demonstrated in consultation with the industry.

### 1.1 Compliance Notation

As used in this document, "*shall*" denotes a mandatory provision of the standard. "*Should*" denotes a provision that is recommended but not mandatory. "*May*" denotes a feature whose presence does not preclude compliance that may or may not be present at the option of the implementer.

## 2 Generic Reference Model for the common functional requirements of a satellite IRD

A Generic Reference Model for the Common Functional Requirements of a Satellite IRD has been produced in order to analyze the feasibility of the universal elements of a satellite IRD, identifying the applicability of the generic reference model to the two systems currently in use.

The Generic Reference Model has been defined based on the functions required for covering all layers of a typical IRD Protocol Stack. For reference, Fig. 1 presents the typical IRD Protocol Stack which is based on the following layers:

- **Physical and Link layers** covering the typical front-end functions: tuner, QPSK demodulator, convolutional decoding, deinterleaving, Reed Solomon decoding and energy dispersal removal.



- **Transport layer** responsible of the demultiplexing of the different programs and components as well as the depacketization of the information (video, audio and data)
- **Conditional Access** functions which control the operation of external decoder functions (Common Interface for Conditional Access as an option)
- **Network Services** performing the Video and Audio decoding as well as the management of EPG (Electronic Program Guide) functions and Service Information and, optionally, data decoding.
- **Presentation Layer** responsible, among other things, of the User Interface, operation of the remote control, etc.
- **Customer services** covering the different applications based on Video, Audio and Data.

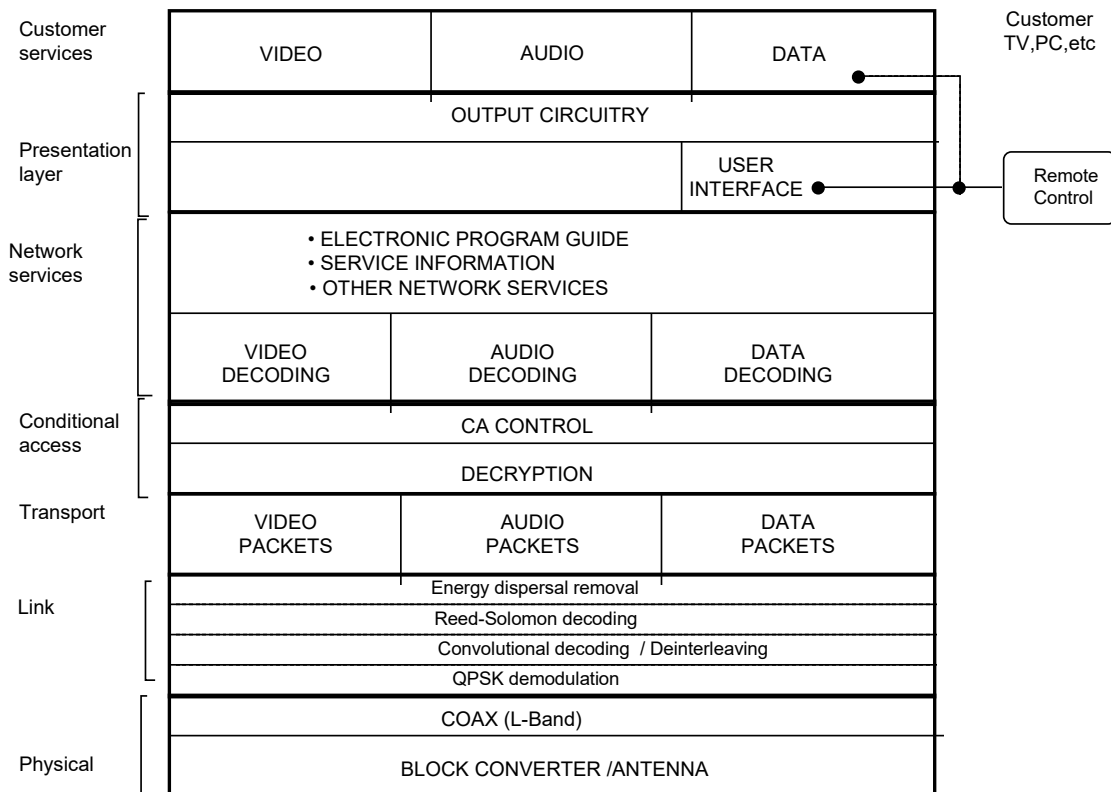

**Figure 1 - Typical IRD protocol stack**

Based on the Protocol Stack, the Generic Reference Model for the Satellite IRD (Fig. 2) is derived.

Two types of functions are identified in the Generic Reference Model: IRD Core functions and other additional essential functions.

- **The IRD Core functions** cover the key IRD functions which define the Digital TV system. IRD core functions include:

- Demodulation and decoding
  - Transport and Demultiplexing
  - Source decoding Video, Audio and Data
- **The additional essential functions** are required to perform the operation of the system and upgrade it with additional and/or complementary features. These functions are closely related to the service provision. The following functions and blocks could be considered as the additional essential functions and may differentiate one IRD from another:
- Satellite tuner
  - Output interfaces
  - Operative System and applications
  - EPG (Electronic Program Guide)
  - SI (Service/System Information)
  - CA (Conditional Access)
  - Display, remote control and different commands
  - ROM, RAM and FLASH memory
  - Interactive module
  - Microcontroller
  - Other functions as Teletext, Subtitling, etc.

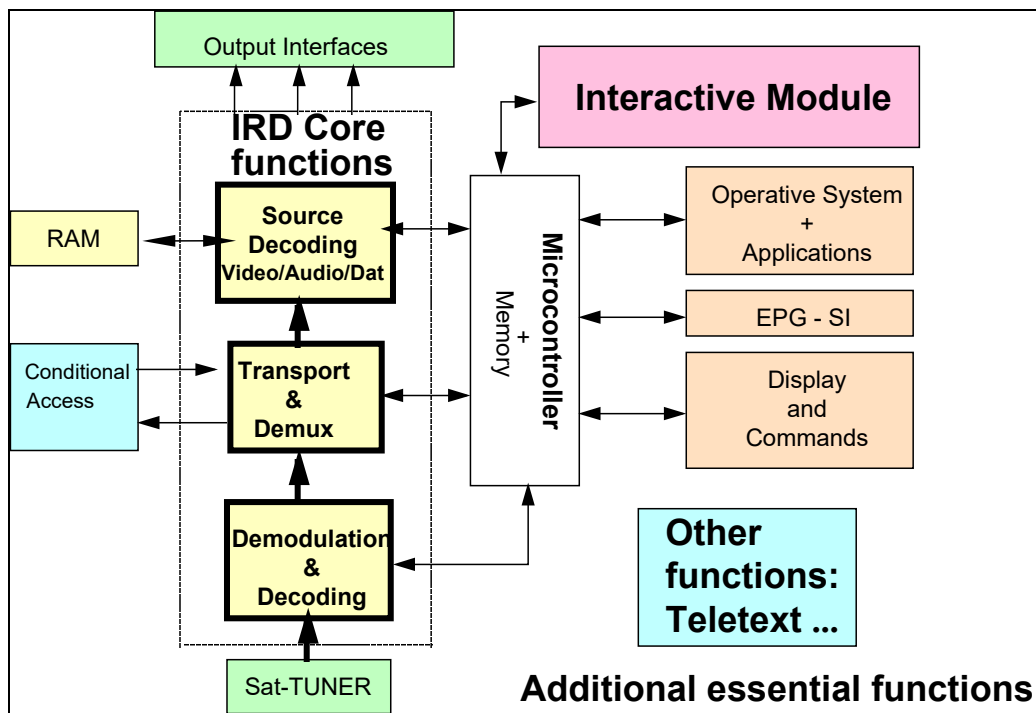

## Figure 2 - Generic reference model for a satellite IRD

### 3 Universal elements of a satellite IRD

An analysis of the core and essential functions of the two systems, as provided in § 4, validated the feasibility to define universal elements for a satellite IRD.

The universal elements of a satellite IRD perform the following functions:

- Demodulation and decoding
- Transport and Demultiplexing
- Source decoding of Video, Audio and Data

It is understood that definition of additional essential functions is out of the scope of this standard because these functions would be specific to each service and very close to the specific implementation by each manufacturer, subject to a number of external and service conditions. Therefore the potential diversity of additional essential functions among satellite IRD's does not impact on the universal elements of the satellite IRD.

#### 3.1 Demodulation and decoding

The block diagram of the demodulation and decoding functions for the universal elements of a satellite IRD is presented in Fig. 3. Overlapped blocks represent functions with common elements for the two systems although with different characteristics. Dashed blocks represent functions not utilized by both systems.

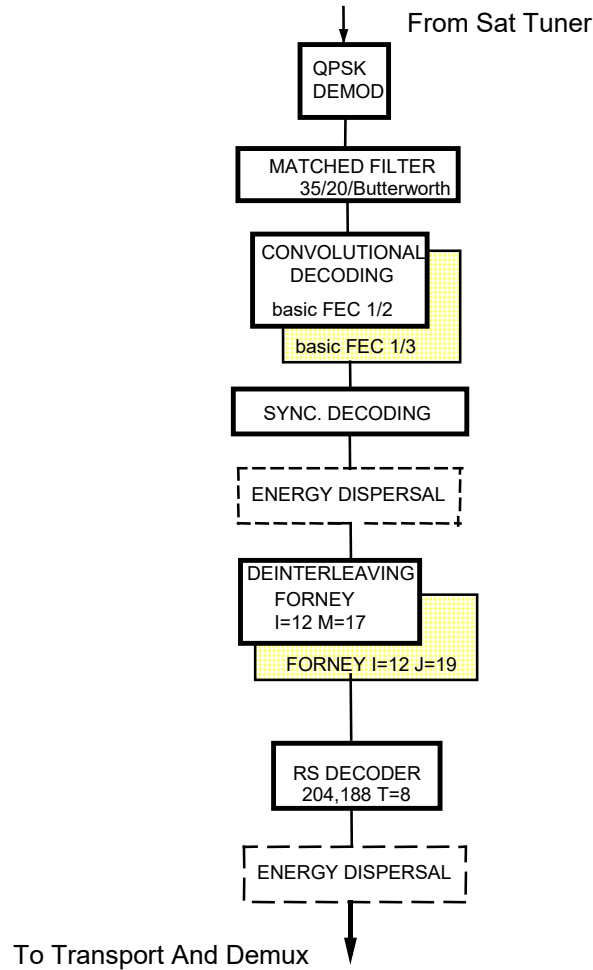

**Figure 3 – Block diagram for demodulation and channel decoding**

### 3.1.1 QPSK demodulator

This universal element of a satellite IRD performs the quadrature coherent demodulation function and the analog to digital conversion, providing “soft decision” I and Q information to the inner decoder.

This universal element of a satellite IRD shall be capable of demodulating a signal employing conventional Gray-coded QPSK modulation with absolute mapping (no differential coding).

Bit mapping in the signal as given on Fig. 4 shall be used.

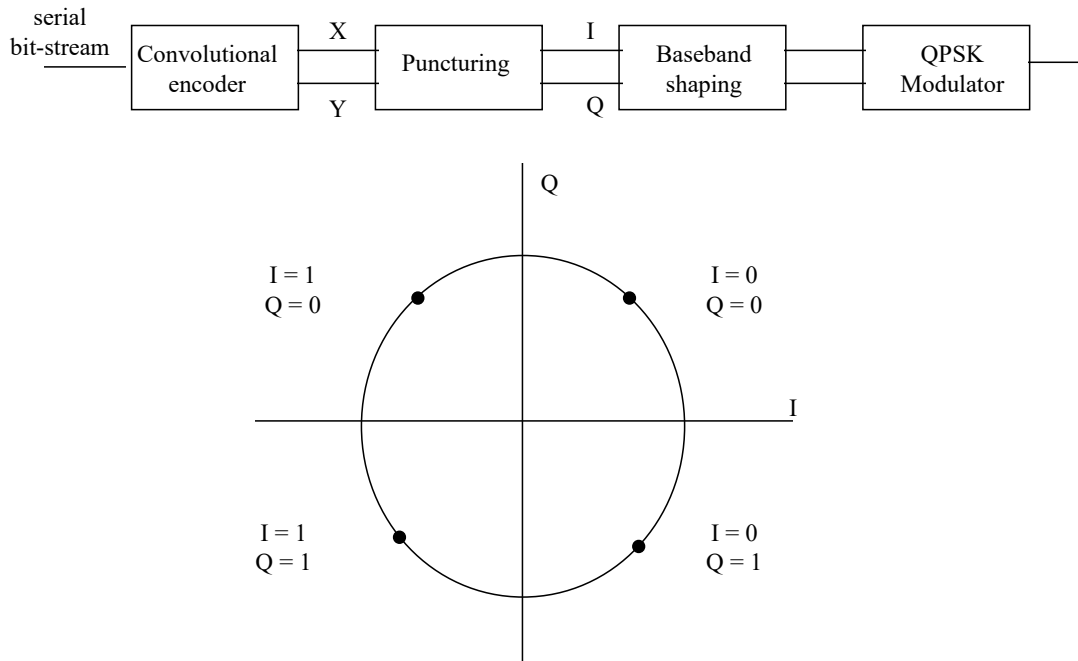

**Figure 4 - QPSK constellation**

### 3.1.2 Matched filter

This universal element of a satellite IRD performs the complementary pulse shaping filtering type according to the roll-off. The use of a Finite Impulse Response (FIR) digital filter could provide equalization of the channel linear distortions in the IRD.

This universal element of a satellite IRD shall be capable of processing signal with the following shaping and roll-off factors:

Square Root Raised Cosine:  $\alpha=0.35$  and  $0.20$

Band-limited 4th order Butterworth Standard and Truncated-spectrum modes

Information about the template for the signal spectrum at the modulator output is given in § 5.1.

### 3.1.3 Convolutional decoding

This universal element of a satellite IRD performs first level error protection decoding. It will operate at an input equivalent “hard decision” BER in the order of between  $10^{-1}$  and  $10^{-2}$  (depending on the adopted code rate), and will produce an output BER about  $2 \times 10^{-4}$  or lower. This output BER corresponds to QEF service after outer code correction. It is possible that this unit makes use of “soft decision” information. This unit is in a position to try each of the code rates and puncturing configurations until lock is acquired. Furthermore, it is in a position to resolve  $\pi/2$  demodulation phase ambiguity.

The inner code has the following characteristics:

- Viterbi and puncturing
- Code constraint length  $K = 7$

This universal element of a satellite IRD shall be capable of decoding the two different convolutional codes. The system shall allow convolutional decoding with code rates based on a rate of either 1/2 or 1/3:

- Based on a basic rate 1/2: FEC= 1/2, 2/3, 3/4, 5/6, 6/7 and 7/8.
- Based on a basic rate 1/3: FEC= 5/11, 1/2, 3/4, 2/3, 3/5, 4/5, 5/6, and 7/8.

Specific characteristics are provided in § 5.2.

### 3.1.4 Sync byte decoder

This universal element shall decode the sync bytes. This decoder provides synchronization information for the deinterleaving. It is also in a position to recover  $\pi$  ambiguity of QPSK demodulator (not detectable by the Viterbi decoder).

Specific characteristics are provided in § 5.3.

### 3.1.5 Convolutional deinterleaver

This universal element allows the error bursts at the output of the inner decoder to be randomized on a byte basis in order to improve the burst error correction capability of the outer decoder.

This universal element of a satellite IRD shall be capable of receiving Ramsey Type III (Forney approach) (I=12, M=17 and J=19) convolutional interleaver systems, as specifically defined in § 5.4.

### 3.1.6 Reed Solomon decoder

This universal element of a satellite IRD provides second level error protection. It is in a position to provide QEF output (i.e. BER of about  $10^{-10}$  and  $10^{-11}$ ) in the presence of input error bursts at a BER of about  $7 \times 10^{-4}$  or better with infinite byte interleaving. In the case of interleaving depth I = 12, BER =  $2 \times 10^{-4}$  is assumed for QEF.

This universal element of a satellite IRD shall decode the following characteristics:

- Reed Solomon Generator: (255,239, T=8) shortened to (204,188, T=8)
- Reed Solomon Code Generator polynomial:  $(x+\alpha^0)(x+\alpha^1) + \dots (x+\alpha^{15})$  or  $(x+\alpha^1)(x+\alpha^2) + \dots (x+\alpha^{16})$  where  $\alpha = 02\text{HEX}$ .
- Reed Solomon field generator polynomial:  $x^8 + x^4 + x^3 + x^2 + 1$

Specific characteristics are provided in § 5.5.

### 3.1.7 Energy dispersal removal

This universal element of a satellite IRD recovers the user data by removing the randomizing pattern used for energy dispersal purposes. It can be implemented in such a way to be capable of derandomizing signals where the derandomization process has been placed before deinterleaving or after RS decoder. This universal element of a satellite IRD may implement a bypass to this feature.

Specific characteristics are provided in § 5.6.

### 3.2 Transport and demultiplexing

The block diagram of the Transport and Demultiplexing functions for the satellite IRD is presented in Fig. 5.

The system shall be capable of receiving and demultiplexing packets following MPEG-2 transport multiplexer (see ISO/IEC 13818-1 [1]) as well as transport stream specific characteristics defined in § 5.7.

Conditional Access is out of the scope of this standard.

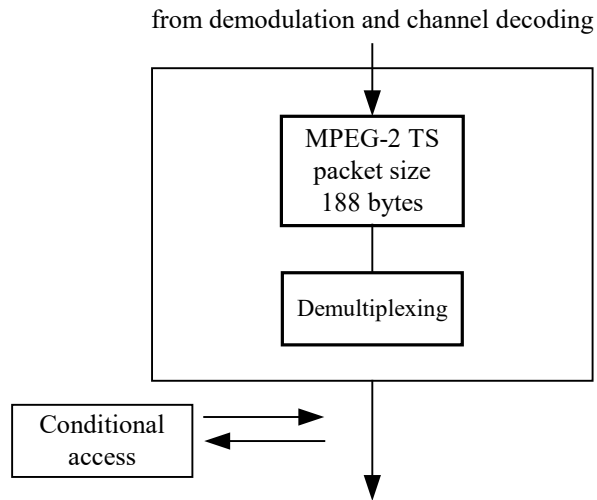

**Figure 5 - Block diagram for transport and demultiplexing**

### 3.3 Source decoding of video, audio and data

The block diagram of the Source Decoding of Video, Audio and Data functions for the satellite IRD is presented in Fig. 6.

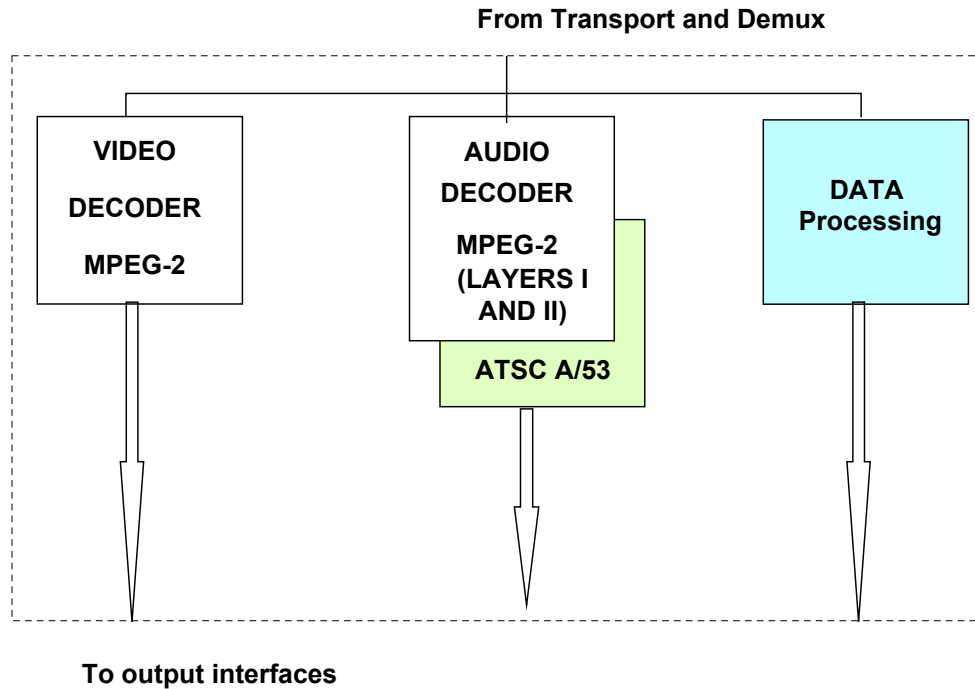

**Figure 6 - Block diagram for source decoding**

### 3.3.1 Video

This universal element of a satellite IRD shall require, as a minimum, the decoding of video formats following the main profile main level MPEG-2 signals which have been coded as specified in ISO/IEC 13818-2 [2].

### 3.3.2 Audio

This universal element of a satellite IRD shall require the decoding of audio signals following the MPEG-2 Layers I and II (ISO/IEC 11172-3 [3]) and Recommendation ITU -R BS.1196, Annex 2 [6] with constraints specified in ATSC-A/53 Annex B [4].

### 3.3.3 Data

This block addresses the functions to process the data associated to the transport multiplex. This item is out of the scope of this standard.

## 4 Summary characteristics of digital multiprogram TV systems by satellite

Table 1 provides information on relevant parameters which characterize the systems in use in the world. It includes core functions as well as additional essential functions.



**Table 1 - Summary characteristics of digital multiprogram TV systems by satellite  
(Normative)**

<i>Demodulation and Channel Decoding</i>		
<b>Function</b>	<b>System I (See Reference [5])</b>	<b>System II</b>
Sync byte substitution	From 47 HEX to B8 HEX	16 bit sync word substituted for two 47 HEX sync bytes
Randomization for energy dispersal	PRBS: $1+X^{14}+X^{15}$	PRBS: $1+X+X^3+X^{12}+X^{16}$ truncated for a period of 4894 bytes
Synchronous randomization	YES	
Loading sequence into PRBS reg.	100101010000000	0001 (HEX)
Place for derandomization application at the IRD	After RS decoder	Before deinterleaver
Reed-Solomon Outer code	(204, 188, T=8)	(204, 188, T=8)
RS Generator	(255, 239, T=8)	
RS code generator polynomial.	$(X+\alpha^0)(X+\alpha^1)\dots(X+\alpha^{15})$ where $\alpha=02$ HEX	$(X+\alpha^1)(X+\alpha^2)\dots(X+\alpha^{16})$ where $\alpha=02$ HEX
RS field generator polynomial.	$X^8 + X^4 + X^3 + X^2 + 1$	
Interleaving	Conv. I=12, M=17 (Forney)	Conv. I=12, J=19 (Forney)
Inner coding	Convolutional	
Code constraint length	K = 7	
Basic code	1/2	1/3
Generator Polynomial	171, 133 (octal)	117, 135, 161 (octal)
FEC	1/2, 2/3, 3/4, 5/6 and 7/8	1/2, 2/3, 3/4, 3/5, 4/5, 5/6, 5/11 and 7/8
Signal Modulation	QPSK	QPSK, OQPSK
Symbol Rate	Variable	
Symbol Rate Range	Continuously variable, from 3 to 30.8 MSymbol/Sec	19.5 and 29.3 Mbaud
Occupied Bandwidth (-3 dB)	Variable	y MHz where y = Symbol rate
Allocated Bandwidth (-25 dB)	Variable	1.33xSymbol rate MHz (optionally 1.55xSymbol rate) for x = 19.5 and 29.3Mbaud
Baseband Shaping Roll-off	0.35 (square root raised cosine)	[Bandwidth limited 4 <sup>th</sup> order Butterworth, Standard and Truncated-spectrum modes approximately equivalent to $\alpha=0.55$ and $\alpha=0.33$ , respectively]

## 5 Specific characteristics

### 5.1 Signal spectrum of the different systems at the modulator output

#### 5.1.1 Signal spectrum for System I

System I uses square root raise cosine roll-off factor of 0.35.

Fig. 7 gives a template for the signal spectrum at the modulator output.

Fig. 7 also represents a possible mask for a hardware implementation of the Nyquist modulator filter. The points A to S shown in Figs. 7 and 8 are defined in Table 2. The mask for the filter frequency response is based on the assumption of ideal Dirac delta input signals, spaced by the symbol period  $T_s = 1/R_s = 1/2f_N$ , while in the case of rectangular input signals a suitable  $x/\sin x$  correction shall be applied on the filter response.

Fig. 8 gives a mask for the group delay for the hardware implementation of the Nyquist modulator filter.

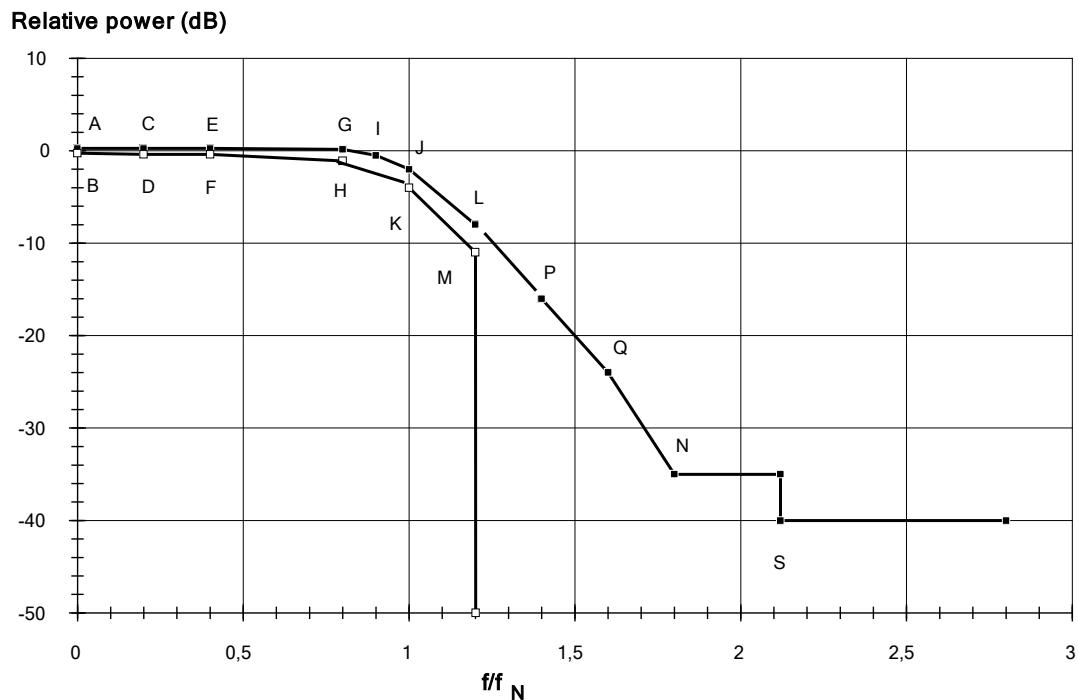

**Figure 7 - Template for the signal spectrum mask at the modulator output represented in the baseband frequency domain**

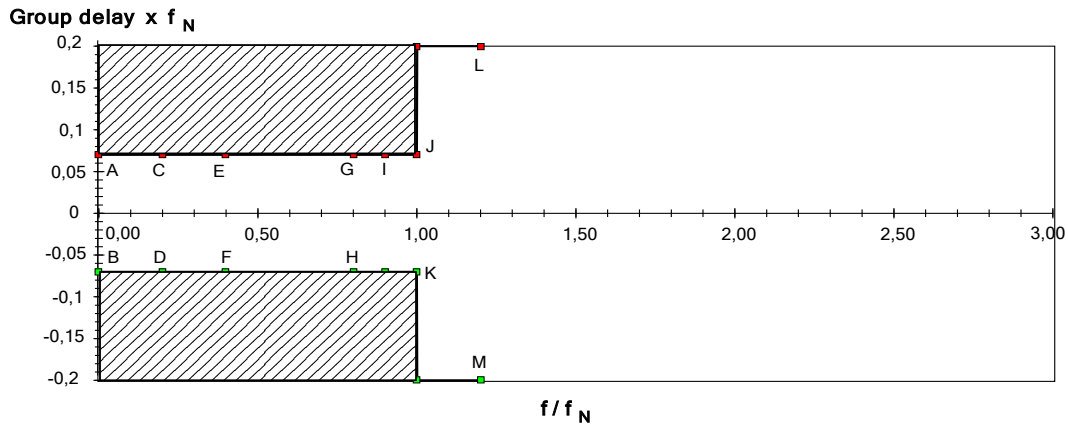

**Figure 8 - Template Of The Modulator Filter Group Delay**

**Table 2 - Definition of points given in Fig. 7**

Point	Frequency	Relative power (dB)	Group delay
A	0,0 f <sub>N</sub>	+0.25	+0.07 / f <sub>N</sub>
B	0.0 f <sub>N</sub>	-0.25	-0.07 / f <sub>N</sub>
C	0.2 f <sub>N</sub>	+0.25	+0.07 / f <sub>N</sub>
D	0.2 f <sub>N</sub>	-0.40	-0.07 / f <sub>N</sub>
E	0.4 f <sub>N</sub>	+0.25	+0.07 / f <sub>N</sub>
F	0,4 f <sub>N</sub>	-0.40	-0.07 / f <sub>N</sub>
G	0.8 f <sub>N</sub>	+0.15	+0.07 / f <sub>N</sub>
H	0.8 f <sub>N</sub>	-1.10	-0.07 / f <sub>N</sub>
I	0.9 f <sub>N</sub>	-0.50	+0.07 / f <sub>N</sub>
J	1.0 f <sub>N</sub>	-2.00	+0.07 / f <sub>N</sub>
K	1.0 f <sub>N</sub>	-4.00	-0.07 / f <sub>N</sub>
L	1.2 f <sub>N</sub>	-8.00	-
M	1.2 f <sub>N</sub>	-11.00	-
N	1.8 f <sub>N</sub>	-35.00	-
P	1.4 f <sub>N</sub>	-16.00	-
Q	1.6 f <sub>N</sub>	-24.00	-
S	2.12 f <sub>N</sub>	-40.00	-

## 5.1.2 Signal spectrum for System II

This section defines System II design recommendations for baseband signal shaping and the modulator output spectrum.

### 5.1.2.1 Baseband signal shaping

System II uses bandlimited 4th-order Butterworth filtering in standard or truncated-spectrum mode, depending on the system requirements.

#### 5.1.2.1.1 Amplitude response

Figs. 9a and 9b show the recommended standard and truncated-spectrum mode design goals for baseband signal shaping spectral density as normalized to the transmit symbol rate. Table 3a and Table 3b tabulate the corresponding breakpoints for standard and truncated-spectrum modes, respectively.

**Table 3a - Spectral density mask breakpoints for standard mode**

Frequency offset normalized to transmit symbol rate	Upper mask breakpoints (dB)	Lower mask breakpoints (dB)
0.0	0.1	-0.1
0.25	0.1	-0.1
0.3125	0.0	-0.2
0.375	-0.35	-0.55
0.4375	-1.25	-1.45
0.50	-3.0	-3.50
0.5625	-5.85	-6.85
0.625	-10.25	-11.25
0.6875	-15.55	-16.55
0.75	-22.05	-23.05
0.8125	-32.3	-33.3
0.8125		-50.0
1.0	-40.0	

**Table 3b - Spectral density mask breakpoints for truncated-spectrum mode**

Frequency offset normalized to transmit symbol rate	Upper mask breakpoints (dB)	Lower mask breakpoints (dB)
0.0	0.1	-0.1
0.25	0.1	-0.1
0.3125	-0.15	-0.35
0.375	-0.35	-0.55
0.4375	-1.0	-1.2
0.50	-2.9	-3.4
0.5625	-7.4	-8.4
0.625	-16.6	-17.6
0.654	-24.5	-25.5
0.654		-50.0
0.75	-31.8	
1.0	-40.0	

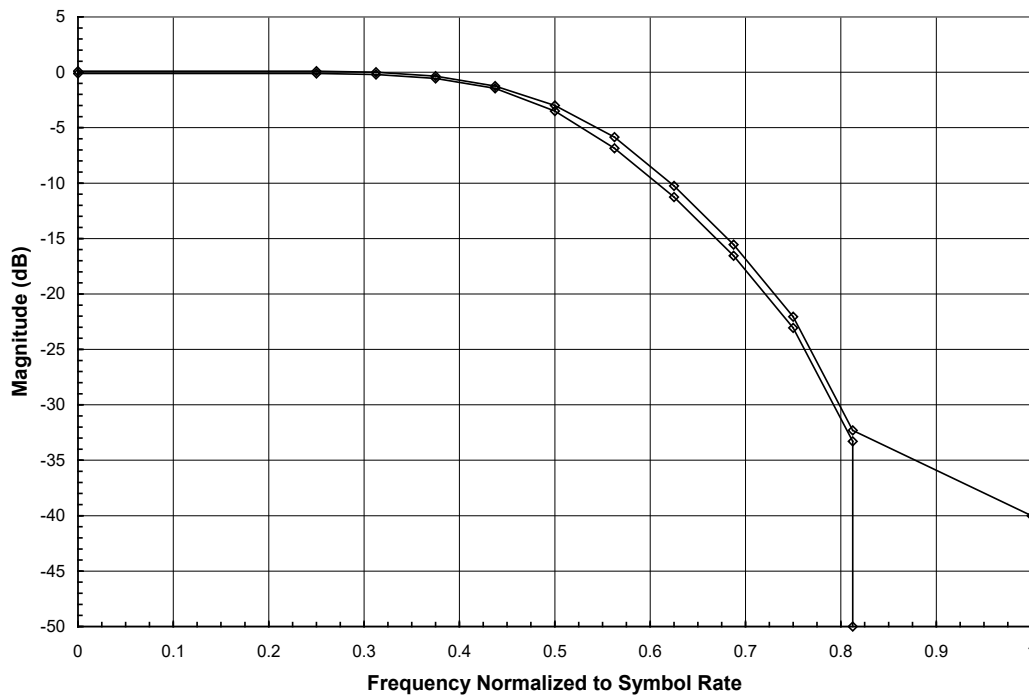

**Figure 9a - Spectral density mask for standard mode**

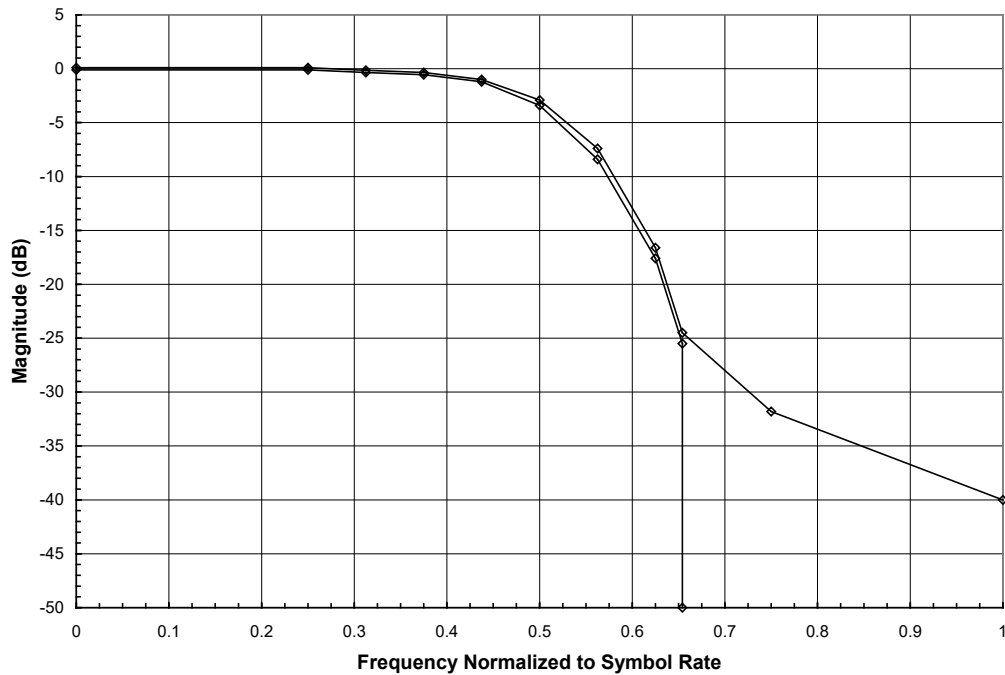

**Figure 9b - Spectral density mask for truncated-spectrum mode**

#### 5.1.2.1.2 Group delay response

Figs. 10a and 10b show the recommended standard and truncated-spectrum mode design goals for baseband signal shaping group delay as normalized to the transmit symbol rate. Tables 4a and 4b tabulate the corresponding breakpoints for standard and truncated-spectrum modes, respectively. The actual required group delay can be obtained by dividing the table values by the symbol rate in Hz; for example, for 29.27 Msps second operation the standard mode upper mask point at a frequency offset of  $0.3 \times 29.27 \text{ MHz} = 8.78 \text{ MHz}$  is found from Table 4a to be  $(-0.20/29.27 \times 10^6 \text{ Hz}) = -6.8 \times 10^{-9} \text{ sec} = -6.8 \text{ nsec}$ .

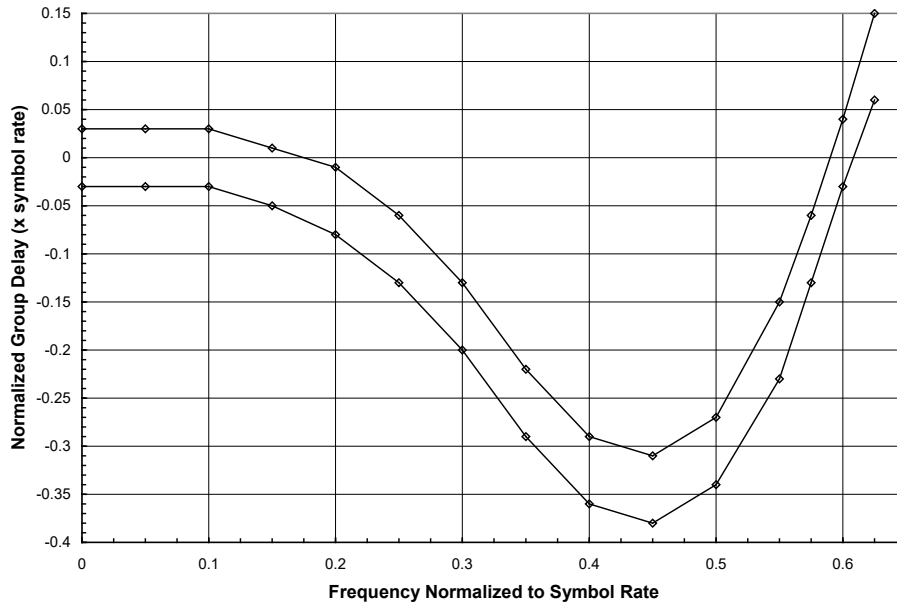

**Figure 10a - Normalized group delay mask for standard mode**

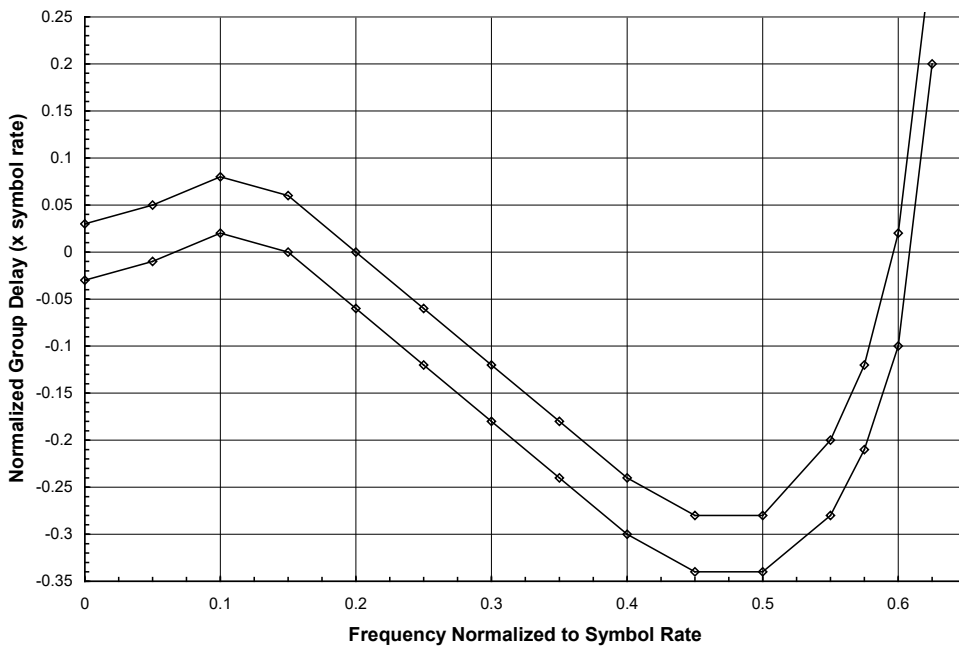

**Figure 10b - Normalized group delay mask for truncated-spectrum mode**

**Table 4a - Normalized group delay breakpoints for standard mode**

Frequency Offset Normalized to Symbol Rate	Lower Mask Group Delay Normalized to Symbol Rate (Delay * ( $f_{\text{sym}}$ in Hz))	Upper Mask Group Delay Normalized to Symbol Rate (Delay * ( $f_{\text{sym}}$ in Hz))
0.0	-0.03	0.03
0.05	-0.03	0.03
0.10	-0.03	0.03
0.15	-0.05	0.01
0.20	-0.08	-0.01
0.25	-0.13	-0.06
0.30	-0.20	-0.13
0.35	-0.29	-0.22
0.40	-0.36	-0.29
0.45	-0.38	-0.31
0.50	-0.34	-0.27
0.55	-0.23	-0.15
0.575	-0.13	-0.06
0.60	-0.03	0.04
0.625	0.06	0.15

**Table 4b - Normalized group delay breakpoints for truncated-spectrum mode**

Frequency Offset Normalized to Symbol Rate	Lower Mask Group Delay Normalized to Symbol Rate (Delay * ( $f_{\text{sym}}$ in Hz))	Upper Mask Group Delay Normalized to Symbol Rate (Delay * ( $f_{\text{sym}}$ in Hz))
0.0	-0.03	0.03
0.05	-0.01	0.05
0.10	0.02	0.08
0.15	-0.00	0.06
0.20	-0.06	-0.0
0.25	-0.12	-0.06
0.30	-0.18	-0.12
0.35	-0.24	-0.18
0.40	-0.30	-0.24
0.45	-0.34	-0.28
0.50	-0.34	-0.28
0.55	-0.28	-0.20
0.575	-0.21	-0.12
0.60	-0.10	0.02
0.625	0.20	0.32



### 5.1.2.2 Modulator response

The recommended modulator output spectral response for System II is shown in Fig. 10c and tabulated in Table 4c.

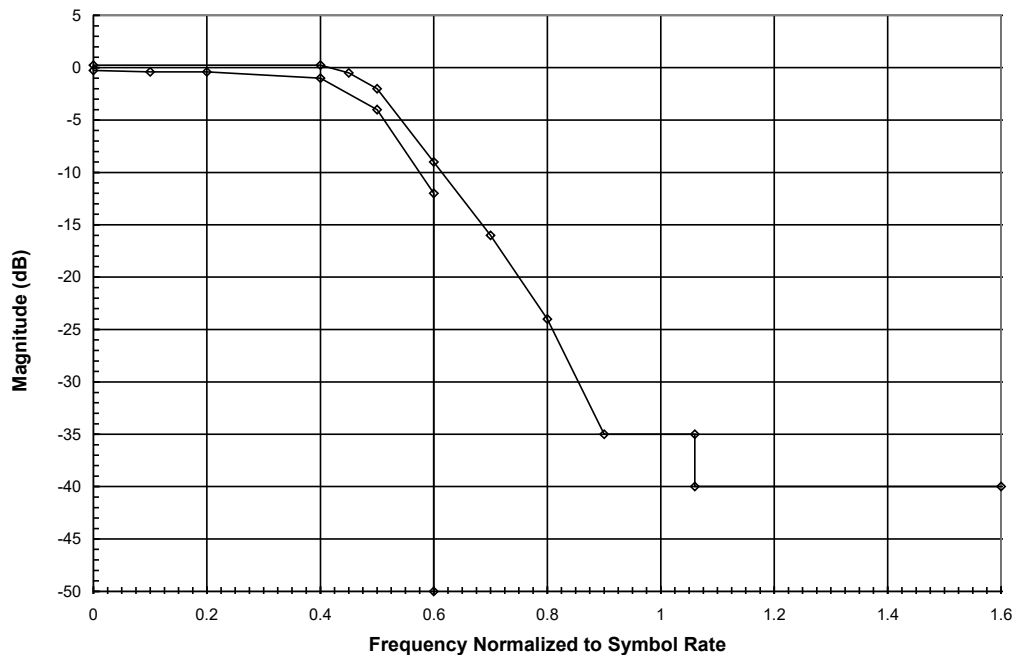

Figure 10c - System II spectral mask

Table 4c - System II spectral mask

Frequency Offset Normalized to Transmit Symbol Rate	Upper Mask Breakpoints (dB)	Lower Mask Breakpoints (dB)
0.0	0.25	-0.25
0.1		-0.4
0.2		-0.4
0.4	0.25	-1.0
0.45	-0.5	
0.5	-2.0	-4.0
0.6	-9.0	-12.0
0.6		-50.0
0.7	-16.0	
0.8	-24.0	
0.9	-35.0	
1.06	-35.0	
1.06	-40.0	
1.6	-40.0	

## 5.2 Convolutional coding

### 5.2.1 Convolutional coding characteristics for System I

Table 5 defines the punctured code definition for System I based on basic code 1/2:

**Table 5 - Punctured code definition**

Original code			Code rates									
			1/2		2/3		3/4		5/6		7/8	
K	G <sub>1</sub> (X)	G <sub>2</sub> (Y)	P	d <sub>free</sub>	P	d <sub>free</sub>	P	d <sub>free</sub>	P	d <sub>free</sub>	P	d <sub>free</sub>
7	171 <sub>OCT</sub>	133 <sub>OCT</sub>	X: 1 Y: 1  I=X <sub>1</sub> Q=Y <sub>1</sub>	10	X: 1 0 Y: 1 1  I=X <sub>1</sub> Y <sub>2</sub> Y <sub>3</sub> Q=Y <sub>1</sub> X <sub>3</sub> Y <sub>4</sub>	6	X: 1 0 1 Y: 1 1 0  I=X <sub>1</sub> Y <sub>2</sub> Q=Y <sub>1</sub> X <sub>3</sub>	5	X: 1 0 1 0 1 Y: 1 1 0 1 0  I=X <sub>1</sub> Y <sub>2</sub> Y <sub>4</sub> Q=Y <sub>1</sub> X <sub>3</sub> X <sub>5</sub>	4	X: 1 0 0 0 1 0 1 Y: 1 1 1 1 0 1 0  I=X <sub>1</sub> Y <sub>2</sub> Y <sub>4</sub> Y <sub>6</sub> Q=Y <sub>1</sub> Y <sub>3</sub> X <sub>5</sub> X <sub>7</sub>	3
NOTE:			1 = transmitted bit 0 = non transmitted bit									

### 5.2.2 Convolutional coding characteristics for System II

The punctured code definition for System II based on basic code 1/3 is as follows:

The following convolutional coding characteristics are included in the coding layer:

- Transmission of bit-by-bit interleaved I and Q multiplex channels is supported by the convolutional encoder.
- The IRD performs convolutional code node and puncture synchronization.
- The convolutional code is punctured from a constraint length 7, rate 1/3 code. The code generators for the rate 1/3 code are G(2) = 1001111 binary (117 octal), G(1) = 1011101 binary (135 octal), and G(0) = 1110001 binary (161 octal). The code generators are defined from the least delayed to the most delayed input bit (see Fig. 11).
- The puncture matrices are as follows:
  - The rate 3/4 puncture matrix is p<sub>2</sub>=[100], p<sub>1</sub>=[001], p<sub>0</sub>=[110] (binary). For output 1, every second and third bit in a sequence of three is deleted, for output 2, every first and second bit is deleted and for output 3 every third output bit is deleted.
  - The rate 1/2 puncture matrix is [0], [1], [1] (binary).
  - The rate 5/11 puncture matrix is [00111], [11010], [11111] (binary).
  - The rate 2/3 puncture matrix is [11], [00], [01] (binary).
  - The rate 4/5 puncture matrix is [0111], [0010], [1000] (binary).

- The rate 7/8 puncture matrix is [0000000], [0000001], [1111111] (binary).
- The rate 3/5 puncture matrix is [001], [010], [111] (binary).
- The rate 5/6 puncture matrix is [00111], [00000], [11001] (binary).
- The output ordering from the convolutional encoder is punctured G2 output, followed by punctured G1 output, followed by punctured G0.
- The first bit of the puncture sequence out of the encoder is applied to the I channel of the QPSK signal in a Combined MUX mode of operation; e.g., in the following diagram (Fig. 12),  $i_0, k_1, i_3, k_4, \dots$  are applied to the I channel while  $k_0, j_2, k_3, j_5, \dots$  are applied to the Q channel.

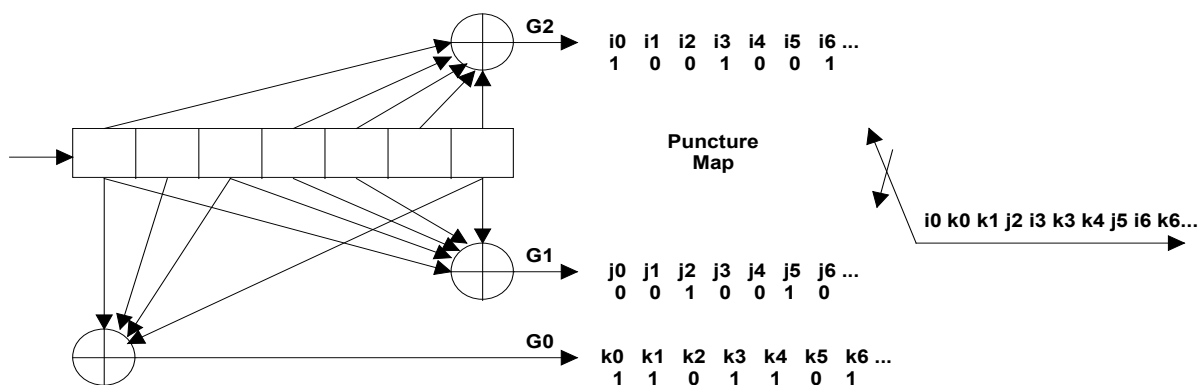

**Figure 11 - Convolutional encoder (rate 3/4 example)**

### 5.3 Synchronization characteristics

#### 5.3.1 Synchronization characteristics for System I

The system input stream shall be organized in fixed length packets, following the MPEG-2 transport multiplexer (see ISO/IEC 13818-1 [1]). The total packet length of the MPEG-2 transport Multiplex (MUX) packet is 188 bytes. This includes 1 sync-word byte (i.e.  $47_{\text{HEX}}$ ). The processing in order at the transmitting side shall always start from the MSB (i.e. “0”) of the sync word-byte (i.e. 01000111).

#### 5.3.2 Synchronization characteristics for System II

The uplink transmission processing facilitates downlink synchronization of the FEC code system by performing MPEG-2 packet reordering and 16 bit frame sync and reserved word formatting. Fig. 12 shows the uplink processing required to ensure that the 16 bit frame sync pattern appears at the Viterbi decoder output in consecutive byte locations every 12 RS block intervals.

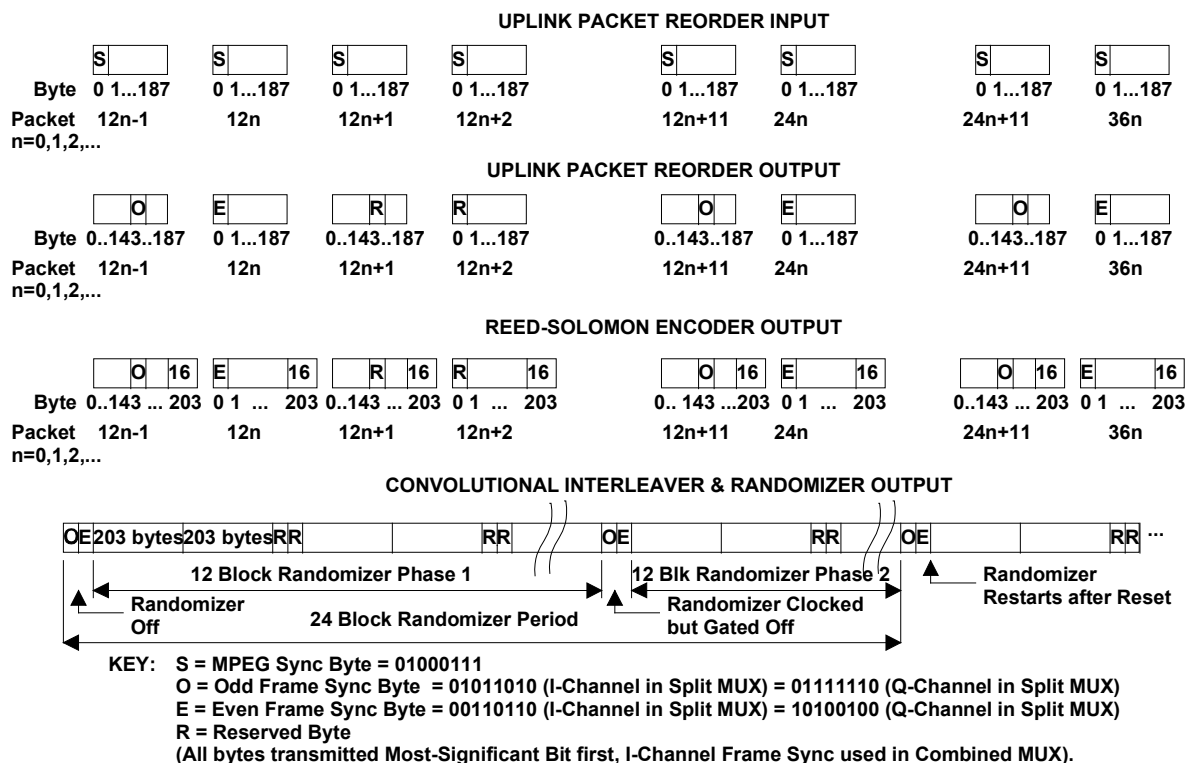

**Figure 12 - Uplink processing**

The following functions are performed by the encoder for synchronization purposes:

- The Uplink Packet Reorder input is a stream of 188 byte MPEG-2 transport packets here byte numbered 0 to 187. The MPEG-2 transport packets can be numbered  $n = 0, 1, 2$ .
- For transport packets numbered 0 modulo-12, the MPEG-2 sync byte number 0 is replaced by the even frame sync byte 00110110 numbered from left-to-right as MSB to LSB. The MSB is transmitted first on the channel. If the current MPEG transport stream is a Q-channel MUX in a Split MUX mode, the even sync byte is 10100100.
- For transport packets numbered 11 modulo-12, the MPEG-2 sync byte number 0 is discarded, byte numbers 1 through 143 are shifted, the odd frame sync byte 01011010 (MSB to LSB, MSB first on the channel) is inserted following MPEG-2 byte 143 (for the Q-Channel MUX in a Split MUX mode, the odd sync byte is 01111110), and MPEG-2 bytes 144 through 187 are appended to complete the packet structure. Fig. 13 shows this odd numbered packet processing.
- For transport packets numbered 2, 4, 6, 8 and 10 modulo-12, the MPEG-2 sync byte number 0 is replaced by a reserved byte.
- For transport packets numbered 1, 3, 5, 7, and 9 modulo-12, the MPEG-2 sync byte number 0 is discarded, byte numbers 1 through 143 are shifted, the reserved byte is inserted following MPEG-2 byte 143 and MPEG bytes 144 through 187 are appended to complete the packet structure.



The convolutional interleaving process shall be based on the Forney approach which is compatible with the Ramsey type III approach, with  $I = 12$ . The interleaved frame shall be composed of overlapping error protected packets and shall be delimited by inverted or non-inverted MPEG-2 sync bytes (preserving the periodicity of 204 bytes).

The interleaver may be composed of  $I = 12$  branches, cyclically connected to the input byte-stream by the input switch. Each branch shall be a First-In, First-Out (FIFO) shift register, with depth  $(M \cdot j)$  cells (where  $M = 17 = N/I$ ,  $N = 204 =$  error protected frame length,  $I = 12 =$  interleaving depth,  $j =$  branch index). The cells of the FIFO shall contain 1 byte, and the input and output switches shall be synchronized.

For synchronization purposes, the sync bytes and the inverted sync bytes shall be always routed in the branch "0" of the interleaver (corresponding to a null delay).

NOTE: The deinterleaver is similar, in principle, to the interleaver, but the branch indexes are reversed (i.e.  $j = 0$  corresponds to the largest delay). The deinterleaver synchronization can be carried out by routing the first recognized sync byte in the "0" branch.

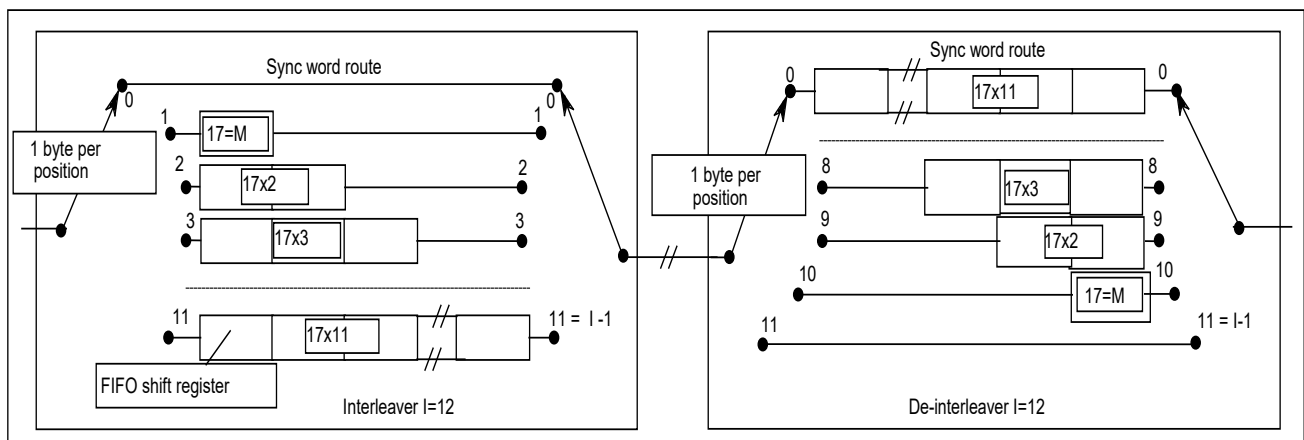

Figure 14 - Conceptual diagram of the convolutional interleaver and deinterleaver

#### 5.4.2 Convolutional interleaver for System II

The coding layer provides convolutional interleaving of 8-bit Reed-Solomon encoder output symbols. The following characteristics define the convolutional interleaving:

- The depth  $I=12$ ,  $J=19$  interleaver consists of an  $I(I-1)J/2 = 1254$  RS symbol memory. The interleaver structure will be compatible with the commutator type as shown in Fig. 15.
- The first byte of a Reed-Solomon encoded output block is input and output on the zero-delay interleaver commutator arm.
- The  $k^{\text{th}}$  commutator arm consists of  $k \cdot J$  byte delays for  $k = 0, 1, \dots, 11$  and  $J=19$ . An output byte is read from the  $k^{\text{th}}$  FIFO or circular buffer, an input byte is written or shifted into the  $k^{\text{th}}$  buffer, and the commutator arm advances to the  $k+1$  interleaver arm. After reading and

writing from the last commutator arm, the commutator advances to the zero-delay arm for its next output.

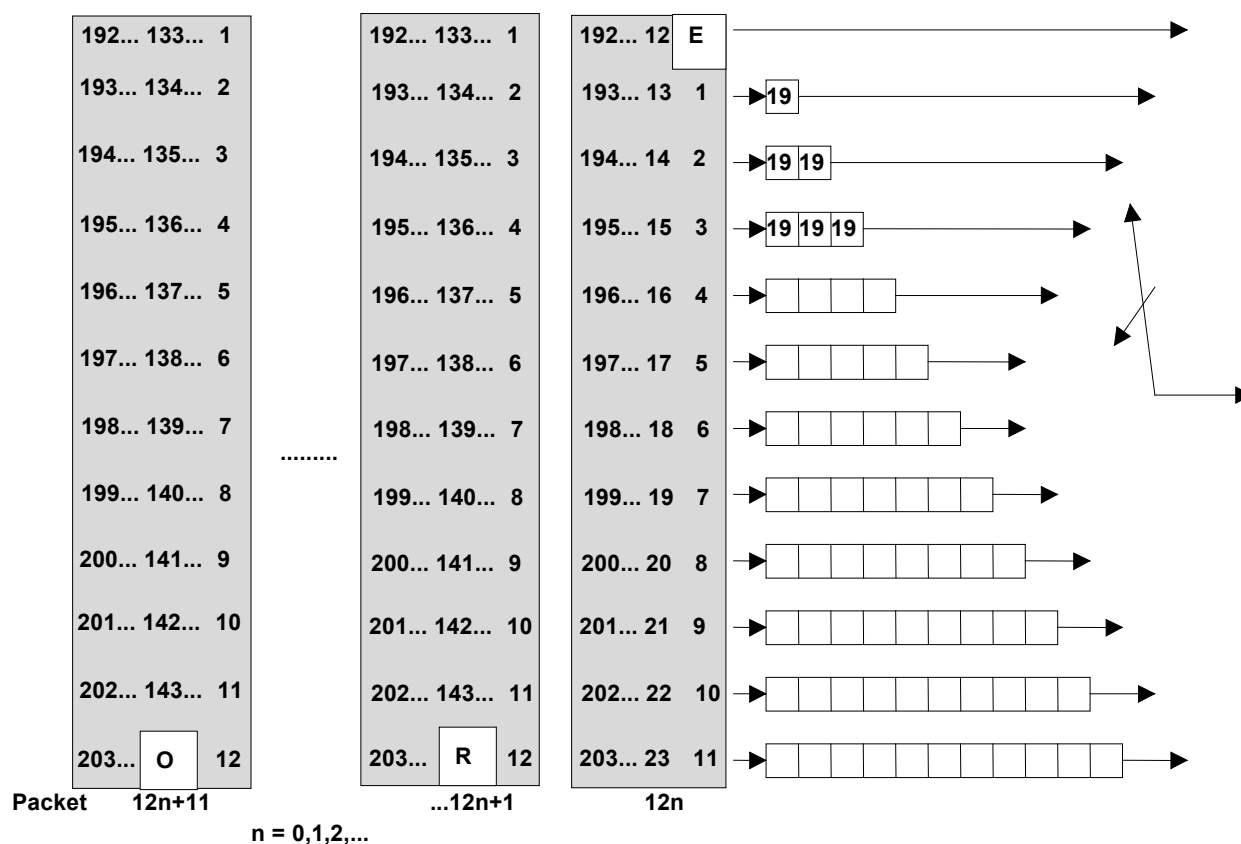

Figure 15 - Convolutional interleaver

## 5.5 Reed Solomon encoder

The Reed Solomon decoder shall be capable of working with the following shortened parameters:

- (204,188,T=8)
- (146,130,T=8)

The shortened Reed-Solomon codes may be implemented by adding bytes (51 for (204,188), and 109 for (146,130)), all set to zero, before the information bytes at the input of a (255,239) encoder. After the RS coding procedure these null bytes shall be discarded.

### 5.5.1 Reed Solomon encoder characteristics for System I

- System I uses: (204,188,T=8)

### 5.5.2 Reed Solomon encoder characteristics for System II

- System II uses: (204,188,T=8)

The Reed-Solomon code is a (204,188)  $m=8$  code with 8-bit symbols, shortened from a block length of 256 symbols, and correcting up to  $t=8$  symbols per block.

The finite field  $GF(256)$  is constructed from the primitive polynomial

$p(x) = x^8 + x^4 + x^3 + x^2 + 1$ . The generator polynomial for the  $t$ -error correcting code has roots at  $x = a^i, i = 1, 2, \dots, 2t$ ,

$$g(x) = \prod_{i=1}^{i=2t} (x + a^i).$$

For  $t = 8$ , the generator polynomial is  $g(x) = x^{16} + a^{121}x^{15} + a^{106}x^{14} + a^{110}x^{13} + a^{113}x^{12} + a^{107}x^{11} + a^{167}x^{10} + a^{83}x^9 + a^{11}x^8 + a^{100}x^7 + a^{201}x^6 + a^{158}x^5 + a^{181}x^4 + a^{195}x^3 + a^{208}x^2 + a^{240}x + a^{136}$

For an  $(N, N - 2t)$  code, an  $N$ -symbol codeword is generated by inputting the data symbols in the first  $N - 2t$  clock cycles, then running the circuit to generate the  $2t$  parity symbols. This encoder is clearly systematic, since the output is identical to the data symbol input for the first  $N - 2t$  cycles. Algebraically, the symbol sequence  $d_{N-2t-1}, d_{N-2t-2}, \dots, d_0$  input into the encoder represents the polynomial  $d(x) = d_{N-2t-1}x^{N-2t-1} + d_{N-2t-2}x^{N-2t-2} + \dots + d_1x + d_0$ . The encoder forms the codeword  $c(x) = x^{2t}d(x) + rmd[d(x) / g(x)]$ , and outputs the coefficients from the highest to lowest order.

The convention of parallel-to-serial conversion from data bits to symbols is that of a left-to-right shift register with the oldest bit forming the LSB and the most recent bit forming the MSB. The RS code is applied to packets as shown in Fig. 16.

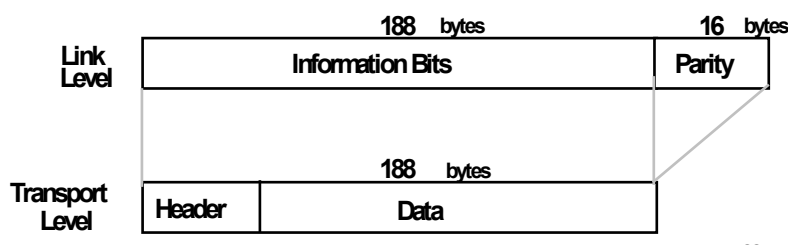

Figure 16 - RS code applied to a packet

## 5.6 Energy dispersal

### 5.6.1 Energy dispersal for System I

System I removes the randomization pattern after Reed Solomon decoding. The polynomial for the Pseudo Random Binary Sequence (PRBS) generator shall be  $1 + X^{14} + X^{15}$  with a loading sequence

“100101010000000”

In order to comply with ITU Radio Regulations and to ensure adequate binary transitions, the data of the input MPEG-2 multiplex shall be randomized in accordance with the configuration depicted in Fig. 2.

The polynomial for the Pseudo Random Binary Sequence (PRBS) generator shall be:



$$1 + X^{14} + X^{15}$$

Loading of the sequence "100101010000000" into the PRBS registers, as indicated in Fig. 17, shall be initiated at the start of every eight transport packets. To provide an initialization signal for the descrambler, the MPEG-2 sync byte of the first transport packet in a group of eight packets is bit-wise inverted from 47<sub>HEX</sub> to B8<sub>HEX</sub>. This process is referred to as the "Transport Multiplex Adaptation".

The first bit at the output of the PRBS generator shall be applied to the first bit (i.e. MSB) of the first byte following the inverted MPEG-2 sync byte (i.e. B8<sub>HEX</sub>). To aid other synchronization functions, during the MPEG-2 sync bytes of the subsequent 7 transport packets, the PRBS generation shall continue, but its output shall be disabled, leaving these bytes unrandomized. Thus, the period of the PRBS sequence shall be 1 503 bytes.

The randomization process shall be active also when the modulator input bit-stream is non-existent, or when it is non-compliant with the MPEG-2 transport stream format (i.e. 1 sync byte + 187 packet bytes). This is to avoid the emission of an unmodulated carrier from the modulator.

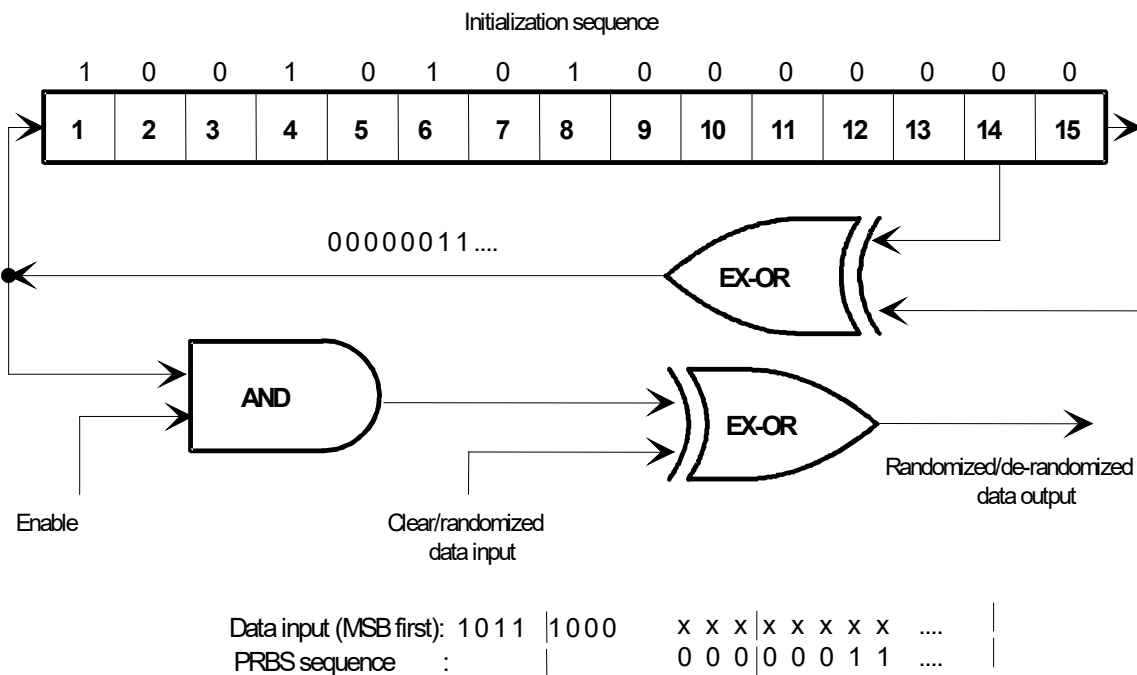

**Figure 17 - Randomizer/de-randomizer schematic diagram**

### 5.6.2 Energy dispersal for System II

System II applies randomization functions after Convolutional decoding. The polynomial for the Pseudo Random Binary Sequence (PRBS) generator shall be  $1 + X + X^3 + X^{12} + X^{16}$ , with a loading sequence "0001<sub>HEX</sub>"

The coding layer uses data randomization (scrambling) at the interleaver output and deinterleaver input for energy dispersal and to ensure a high data transition density for bit timing recovery purposes. The following characteristics define the data randomization:

- The transmit data prior to convolutional coding is randomized via an exclusive-or operation with a truncated  $2^{16}-1$  maximal length pseudorandom (PN) sequence that is restarted every 24 Reed-Solomon encoder block intervals, as shown in Fig. 12.
- The 16 bit FEC sync patterns occurring every 12 RS block intervals are not randomized. The randomizer is clocked during the 16 bit times that FEC sync patterns are inserted, but the randomizer output is not used in the exclusive-or operation with the transmit data.
- The PN sequence is generated from a 16-stage linear feedback shift register with taps at stages 16, 12, 3, and 1 as shown in Fig. 8. The randomizer input is defined as the PN randomization sequence.
- The randomizer is initialized with the value 0001<sub>HEX</sub> at the first bit following the odd-byte/even-byte FEC frame sync word output from the interleaver every 24 blocks.

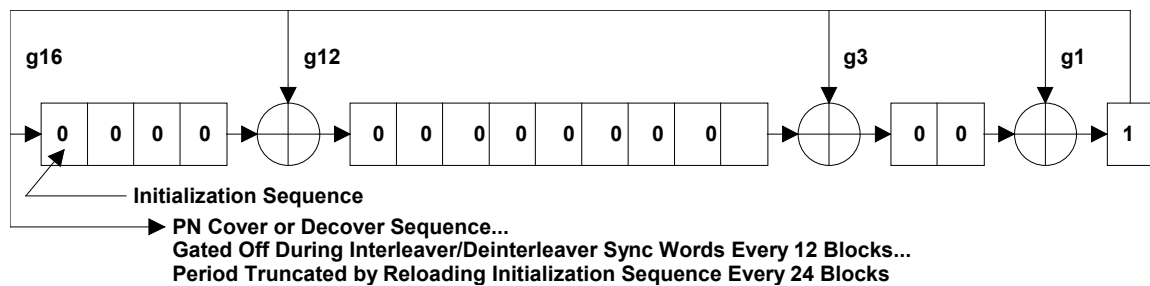

**Figure 18 - Randomizer block diagram**

## 5.7 Framing and Transport stream characteristics

### 5.7.1 Framing and Transport stream characteristics for System I

The framing organization shall be based on the input packet structure (see Fig. 19a).



Figure 19a) MPEG-2 transport MUX packet

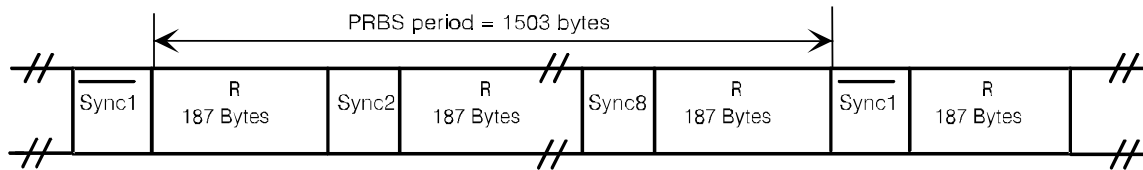

Figure 19b) Randomized transport packets: Sync bytes and randomized sequence R

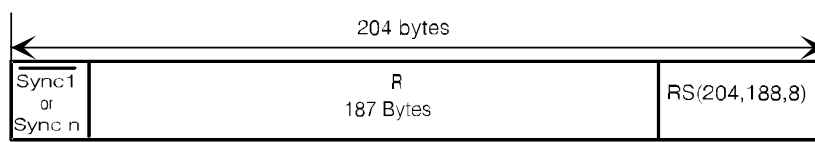

Figure 19c) Reed-Solomon RS (204,188, T=8) error protected packet

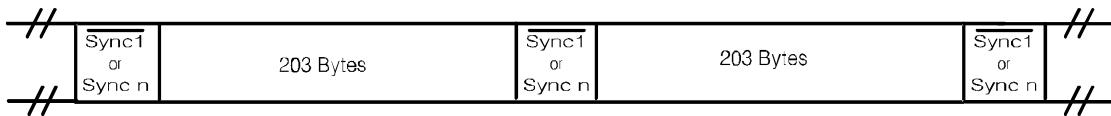

Figure 19d) Interleaved frames; interleaving depth  $l=12$  bytes

Sync1 - not randomized complemented sync byte  
 Sync n - not randomized sync byte,  $n = 2, 3, \dots, 8$

### Figure 19 - Framing structure

### 5.7.2 Framing and Transport stream characteristics for System II

See synchronization characteristics, Section 5.3.

## 6. Normative References

- [1] ISO/IEC 13818-1:2007 Information technology -- Generic coding of moving pictures and associated audio information -- Part 1: Systems (MPEG-2 Systems)
- [2] ISO/IEC 13818-2:2000 Information technology -- Generic coding of moving pictures and associated audio information – Part 2: Video (MPEG-2 Video)
- [3] ISO/IEC 11172-3:1996(E): Information technology -- Generic coding of moving pictures and associated audio for digital storage media at up to about 1,5 Mbit/s – Part 3: Audio (MPEG-1 Audio)
- [4] ATSC A/53C, ATSC Digital Television Standard
- [5] ETS 300 421 “Digital Broadcasting Systems for Television - Framing Structure, Channel Coding and Modulation for 11/12 GHz Satellite Services”
- [6] Recommendation ITU -R BS.1196, Annex 2. Audio Coding for Digital Terrestrial Television Broadcasting.

## 7. List of acronyms

AD	Auxiliary Data
ATM	Asynchronous Transfer Mode
ATSC	Advanced Television Systems Committee
BER	Bit Error Rate
CA	Conditional Access
DEMux	Demultiplexer
DRAM	Dynamic Random Access Memory
DVB	Digital Video Broadcasting
DVB-S	Digital Video Broadcasting Satellite
ETS	European Telecommunication Standard
FEC	Forward Error Correction
GHz	Gigahertz
HEX	Hexadecimal Notation
IRD	Integrated Receiver Decoder
MPEG	Motion Pictures Experts Group
MPEG-2 TS	MPEG-2 Transport Stream
PID	Packet Identifier
PRBS	Pseudo Random Binary Sequence
QAM	Quadrature Amplitude Modulation
QEF	Quasi Error Free
QPSK	Quadrature Phase Shift Keying
RAM	Random Access Memory
ROM	Read Only Memory
RS	Reed Solomon
SCID	Service Channel Identification
SCTE	Society of Cable and Telecommunication Engineers